

TABLE OF CONTENTS FOR THE HST-SM3A MEDIA REFERENCE GUIDE

[HST-SM3A Media Reference Guide Cover](#)

[HST-SM3A Media Reference Guide Introduction](#)

[HST-SM3A Media Reference Guide Glossary](#)

[HST-SM3A Introduction to the Hubble Space Telescope](#)

[1.1 Hubble Space Telescope Configuration](#)

[1.1.1. Optical Telescope Assembly](#)

[1.1.2 The Science Instruments](#)

[1.1.3 Support Systems Module](#)

[1.1.4 Solar Arrays](#)

[1.1.5 Computers](#)

[1.2 The Hubble Space Telescope Program](#)

[1.3 The Value of Servicing](#)

[HST-SM3A Reasons for Orbital Servicing](#)

[2.1 Reasons for Orbital Servicing](#)

[2.2 Orbital Replacement Units](#)

[2.3 Shuttle Support Equipment](#)

[2.3.1 Remote Manipulator System](#)

[2.3.2 Space Support Equipment](#)

[2.3.3 Orbital Replacement Unit Carrier](#)

[2.4 Astronaut Roles and Training](#)

[2.5 Extravehicular Crew Aids and Tools](#)

[2.6 Astronauts of Servicing Mission 3A](#)

[2.7 Servicing Mission Activities](#)

[2.7.1 Rendezvous with the Hubble Space Telescope](#)

[2.7.2 Extravehicular Servicing Activities--Day by Day](#)

[2.8 Future Servicing Plans](#)

[HST-SM3A HST Science and Discoveries](#)

[3.1 Planets](#)

[3.2 Formation and Evolution of Stars and Planets](#)

[3.3 Galaxies and Cosmology](#)

[3.4 Summary](#)

[HST-SM3A Science Instruments](#)

[4.1 Space Telescope Imaging Spectrograph](#)

[4.1.1 Physical Description](#)

[4.1.2 Spectra Operational Modes](#)

[4.1.3 STIS Specifications](#)

[4.1.4 Observations](#)

[4.2 Wide Field and Planetary Camera 2](#)

[4.2.1 Physical Description](#)

[4.2.2 WFPC2 Specifications](#)

[4.2.3. Observations](#)

[4.3 Astrometry \(Fine Guidance Sensors\)](#)

[4.3.1 Fine Guidance Sensor Specifications](#)

[4.3.2 Operational Modes for Astrometry](#)

[4.3.3 Fine Guidance Sensor Filter Wheel](#)

[4.3.4 Astrometric Observations](#)

[HST-SM3A HST Systems](#)

[5.1 Support Systems Module](#)

[5.1.1 Structures and Mechanisms Subsystem](#)

[5.1.2 Instrumentation and Communications Subsystem](#)

[5.1.3 Data Management Subsystem](#)

[5.1.4 Pointing Control Subsystem](#)

[5.1.5 Electrical Power Subsystem](#)

[5.1.6 Thermal Control](#)

[5.1.7 Safing \(Contingency\) System](#)

[5.2 Optical Telescope Assembly](#)

[5.2.1 Primary Mirror Assembly and Spherical Aberration](#)

[5.2.2 Secondary Mirror Assembly](#)

[5.2.3 Focal Plane Structure Assembly](#)

[5.2.4 OTA Equipment Section](#)

[5.3 Fine Guidance Sensor](#)

[5.3.1 Fine Guidance Sensor Composition and Function](#)

[5.3.2 Articulated Mirror System](#)

[5.4 Solar Array and Jitter Problems](#)

[5.4.1 Configuration](#)

[5.4.2 Solar Array Subsystems](#)

[5.4.3 Solar Array Configuration for Servicing Mission 3A](#)

[5.5 Science Instrument Control and Data Handling Unit](#)

[5.5.1 Components](#)

[5.5.2 Operation](#)

[5.6 Space Support Equipment](#)

[5.6.1 Flight Support System](#)

[5.6.2 Orbital Replacement Unit Carrier](#)

[5.6.3 Crew Aids](#)

HST-SM3A HST Operations

6.1 Space Telescope Science Institute

6.1.1 Scientific Goals

6.1.2 Institute Software

6.1.3 Selecting Observation Proposals

6.1.4 Scheduling Selected Observations

6.1.5 Data Analysis

6.2 Space Telescope Operations Control Center

6.3 Operational Characteristics

6.3.1 Orbital Characteristics

6.3.2 Celestial Viewing

6.3.3 Solar System Object Viewing

6.3.4 Natural Radiation

6.3.5 Maneuver Characteristics

6.3.6 Communication Characteristics

6.4 Acquisition and Observation

HST-SM3A Value Added: The Benefits of Servicing Hubble

7.1 Cost-Effective Modular Design

7.1.1 Processor Improvements

[7.1.2 Data Archiving Rate](#)

[7.1.3 Detector Technology](#)

[7.1.4 Cryogenic Cooler](#)

[7.1.5 Solar Arrays](#)

[7.1.6 Simultaneous Science](#)

[7.2 Accelerated Innovations](#)

[7.2.1 Detecting Breast Cancer Before Black Holes](#)

[7.2.2 Image Processing: Diagnosing Cancer Earlier](#)

Hubble Space Telescope



S e r v i c i n g M i s s i o n 3 A
M e d i a R e f e r e n c e G u i d e



3-D Modeling

Three-dimensional modeling simulates an extravehicular activity (EVA) crewmember installing a new computer. This computer will provide six times the memory and 20 times the processor speed of the existing computer.

EVA Crew

EVA crew members gently guide a desk-size Fine Guidance Sensor into place. Fine Guidance Sensors are used for fine pointing control and astrometry science.

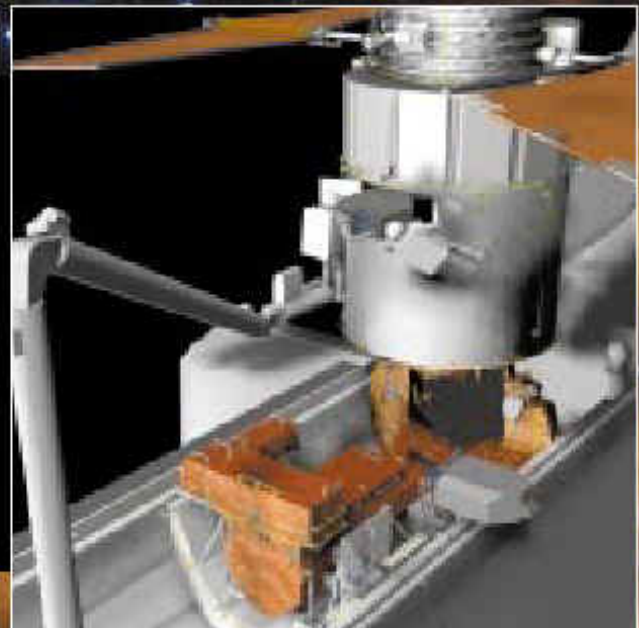



Space-Walking Astronauts

Space-walking astronauts install three Rate Sensor Units, each containing two gyroscopes. These units allow the Telescope to point at stars, planets, and other celestial targets.

Mission Specialist

Discovery's robotic arm transports a Mission Specialist carrying a sheet of the New Outer Blanket Layer to be attached to the exterior of the Telescope. This new layer of insulation corrects damage caused by long-term space exposure.

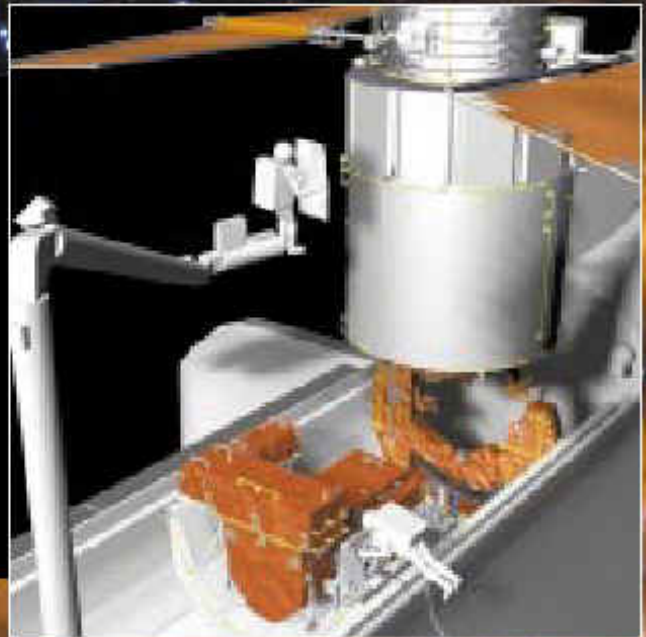

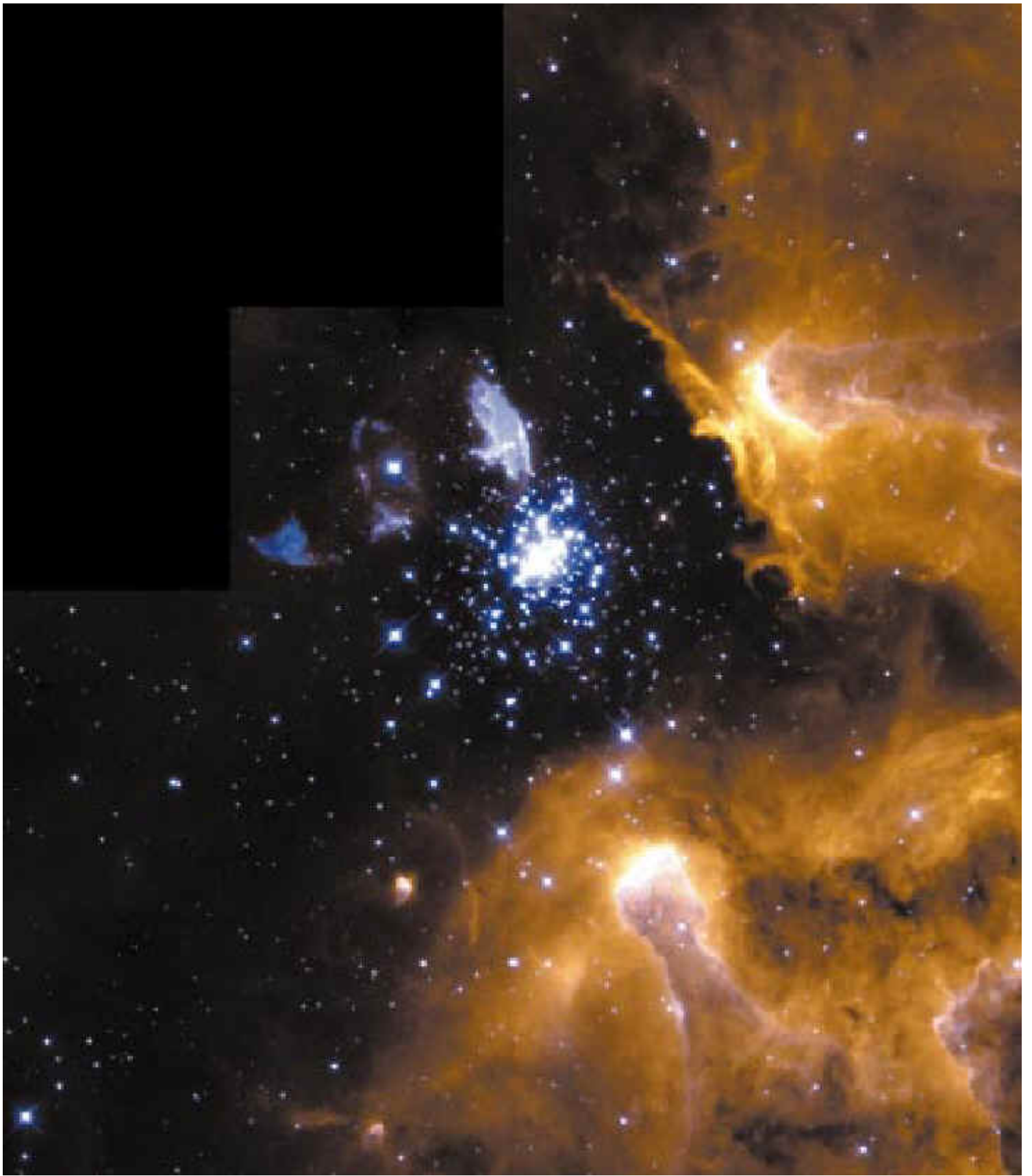

Hubble Space Telescope

Servicing Mission 3A
Media Reference Guide



Prepared for:



By:



Who Was Edwin P. Hubble?

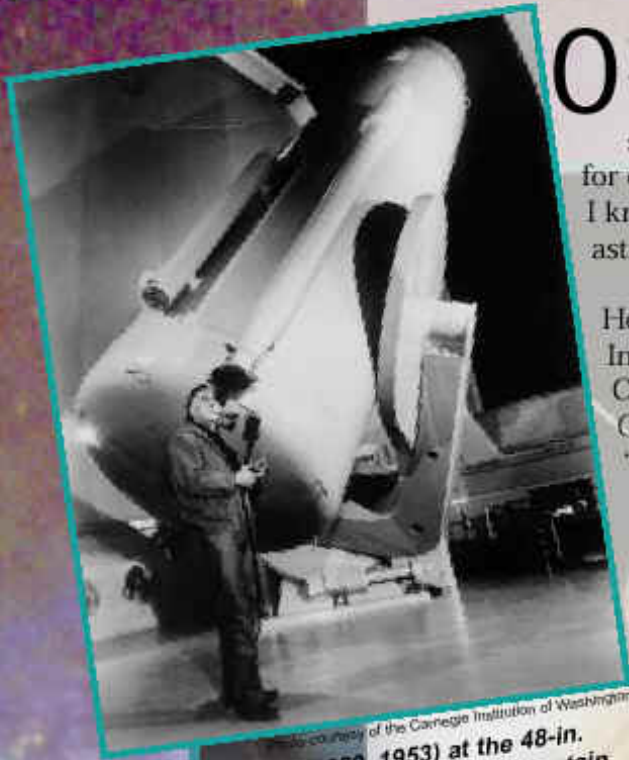

Photo courtesy of the Carnegie Institution of Washington
Edwin Hubble (1889–1953) at the 48-in. Schmidt telescope on Palomar Mountain

One of the great pioneers of modern astronomy, the American astronomer Edwin Powell Hubble (1889–1953), started out by getting a law degree and serving in World War I. However, after practicing law for one year, he decided to “chuck law for astronomy and I knew that, even if I were second rate or third rate, it was astronomy that mattered.”

He completed a Ph.D. thesis on the Photographic Investigation of Faint Nebulae at the University of Chicago and then continued his work at Mount Wilson Observatory, studying the faint patches of luminous “fog” or nebulae in the night sky.

Using the largest telescope of its day, a 2.5-m reflector, he studied Andromeda and a number of other nebulae and proved that they were other star systems (galaxies) similar to our own Milky Way.

He devised the classification scheme for galaxies that is still in use today, and obtained extensive evidence that the laws of physics outside the Galaxy are the same as on Earth – in his own words: “verifying the principle of the uniformity of nature.”

In 1929, Hubble analyzed the speeds of recession of a number of galaxies and showed that the speed at which a galaxy moves away from us is proportional to its distance (Hubble’s Law). This discovery of the expanding universe marked the birth of the “Big Bang Theory” and is one of the greatest triumphs of 20th-century astronomy.

In fact, Hubble’s remarkable discovery could have been predicted some 10 years earlier by none other than Albert Einstein. In 1917, Einstein applied his newly developed General Theory of Relativity to the problem of the universe as a whole. Einstein was very disturbed to discover that his theory predicted that the universe could not be static, but had to either expand or contract. Einstein found this prediction so unbelievable that he went back and modified his original theory in order to avoid this problem. Upon learning of Hubble’s discoveries, Einstein later referred to this as “the biggest blunder of my life.”

Another Step in Our Journey to the Stars

Humankind has sought to expand its knowledge of the universe by studying the stars. Throughout history, great scientists such as Nicolaus Copernicus, Galileo Galilei, Johannes Kepler, Issac Newton, Edwin Hubble, and Albert Einstein have each contributed significantly to our understanding of the universe. The launch of the Hubble Space Telescope in 1990 signified another great step toward unraveling the mysteries of space. Spectacular discoveries such as massive black holes at the center of galaxies, the common existence of precursor planetary systems like our own, and the quantity and distribution of cold dark matter are just a few examples of the Telescope's findings. Now, with NASA's Servicing Mission 3-A, we are equipped to carry the quest for knowledge into the 21st century.

About the Covers

In a single stunning image of the giant galactic nebula NGC 3603, the crisp resolution of NASA's Hubble Space Telescope captures various stages in the life cycle of stars.

The back cover shows the evolved supergiant star called Sher 25 (upper left center). The star has a unique circumstellar ring of glowing gas that is a galactic twin to the famous ring around the supernova 1987A.

Young, hot Wolf-Rayet stars and early O-type stars dominate a starburst cluster near the center of the image. A torrent of ionizing radiation and fast stellar winds from these massive stars has blown a large cavity around the cluster.

The giant gaseous pillars to the right and below the cluster are the most spectacular evidence for the interaction of ionizing radiation with cold molecular-hydrogen cloud material.

Bok globules, the dark clouds in the upper right, are probably in an earlier stage of star formation.

Two compact, tadpole-shaped emission nebulae appear near the lower left of the cluster. Hubble found similar structures in Orion that have been interpreted as gas and dust evaporation from possible protoplanetary disks.

The life cycle of stars begins with the Bok globules and giant gaseous pillars, followed by circumstellar disks, and progresses to evolved massive stars in the young starburst cluster. The blue supergiant with its ring and bipolar outflow marks the end of the life cycle.

The inside covers show 3-D computer models of some of the tasks to be performed in orbit by the STS-103 crew during Servicing Mission 3A. The computer models enabled engineers to study task feasibility and to confirm that astronauts could safely reach and service components and locations on the spacecraft. They provided dimensionally accurate, visually correct images to help the extravehicular activity servicing team prepare to install new components and upgrade functional systems on the Telescope.

GLOSSARY

- [\[A\]](#) [\[B\]](#) [\[C\]](#) [\[D\]](#) [\[E\]](#) [\[F\]](#) [\[G\]](#) [\[H\]](#) [\[I\]](#) [\[J\]](#) [\[K\]](#) [\[L\]](#) [\[M\]](#) [\[N\]](#) [\[O\]](#) [\[P\]](#)
[\[Q\]](#) [\[R\]](#) [\[S\]](#) [\[T\]](#) [\[U\]](#) [\[V\]](#) [\[W\]](#)

-A-

Å	Angstrom
aberration	Property of an optical system that causes an image to have certain easily recognizable flaws. Aberrations are caused by geometrical factors such as the shapes of surfaces, their spacing, and alignments. Image problems caused by factors such as scratches or contamination are not called aberrations.
ACE	Actuator Control Electronics
ACS	Advanced Camera for Surveys
acquisition, target	Orienting the HST line of sight to place incoming target light in an instrument's aperture
actuator	Small, high-precision, motor-driven device that can adjust the location and orientation of an optical element in very fine steps, making fine improvements to the focus of the image
Advanced Computer	A 486-based computer that will replace the DF-224 on SM-3A. Performs onboard computations and handles data and command transmissions between HST systems and the ground system.
AFM	Adjustable Fold Mirror
aft	Rear of the spacecraft

alignment	Process of mounting optical elements and adjusting their positions and orientations so that light follows exactly the desired path through the instrument and each optical element performs its function as planned
altitude	Height in space
AMA	Actuator Mechanism Assembly
AME	Actuator Mechanism Electronics
aperture	Opening that allows light to fall onto an instrument's optics
aplanatic	Image corrected everywhere in field of view
apodizer	Masking device that blocks stray light
arcsec	A wedge of angle, 1/3600th of one degree, in the 360-degree "pie" that makes up the sky. An arcminute is 60 seconds; a degree is 60 minutes
ASCS	Aft Shroud Cooling System
ASLR	Aft Shroud Latch Repair (kits)
ASIPE	Axial Scientific Instrument Protective Enclosure
astigmatism	Failure of an optical system, such as a lens or mirror, to image a point as a single point
astrometry	Geometrical relations of the celestial bodies and their real and apparent motions
ATM	Auxiliary Transport Module
attitude	Orientation of the spacecraft's axes relative to Earth
AURA	Association of Universities for Research for Astronomy
axial science instruments	Four instruments – the STIS, NICMOS, FOC, and COSTAR – located behind the primary mirror. Their long dimensions run parallel to the optical axis of the HST.

baffle	Material that extracts stray light from an incoming image
BAPS	Berthing and Positioning System
BPS	BAPS Support Post

-C-

C	Celsius
Cassegrain	Popular design for large, two-mirror reflecting telescopes in which the primary mirror has a concave parabolic shape and the secondary mirror has a convex hyperbolic shape. A hole in the primary allows the image plane to be located behind the large mirror.
CAT	Crew Aids and Tools
CCC	Charge Current Controller
CCD	Charge-coupled Device
CCS	Control Center System
CDI	Command data interface
change-out	Exchanging a unit on the satellite
cm	Centimeter
collimate	To straighten or make parallel two light paths
coma	Lens aberration that gives an image a "tail"
concave	Mirror surface that bends outward to expand an image
convex	Mirror surface that bends inward to concentrate on an image
coronagraph	Device that allows viewing a light object's corona
COS	Cosmic Origins Spectrograph
COSTAR	Corrective Optics Space Telescope Axial Replacement
CPM	Central Processor Module
CPU	Central Processing Unit

CTVC	Color television camera
CU/SDF	Control Unit/Science Data Formatter
CSS	Coarse Sun Sensor

-D-

diffraction grating	Device that splits light into a spectrum of the component wavelengths
DIU	Data Interface Unit
DMS	Data Management Subsystem
DMU	Data Management Unit
drag, atmospheric	Effect of atmosphere that slows a spacecraft and forces its orbit to decay

-E-

ECA	Electronic Control Assembly
ECU	Electronics Control Unit
electron	Small particle of electricity
ellipsoid	Surface whose intersection with every plane is an ellipse (or circle)
EPDSU	Enhanced Power Distribution and Switching Unit
EPS	Electrical Power Subsystem
EP/TCE	Electrical Power/Thermal Control Electronics
ESA	European Space Agency
E/STR	engineering/science data recorders
EVA	extravehicular activity
extravehicular	Outside the spacecraft; activity in space conducted by suited astronauts

-F-

F	Fahrenheit
FGE	Fine Guidance Electronics
FGS	Fine Guidance Sensor
FHST	Fixed Head Star Tracker
FOC	Faint Object Camera
focal plane	Axis or geometric plane where incoming light is focused by the telescope
FOSR	Flexible optical solar reflector
FOV	Field of view
FPS	Focal plane structure
FPSA	Focal plane structure assembly
FRB	Fastener retention block
FS	Forward shell
FSIPE	FGS Scientific Instrument Protective Enclosure
FSS	Flight Support System

-G-

GA	Gallium arsenide
G/E	Graphite-epoxy
GE	General Electric
GGM	Gravity Gradient Mode
GSE	Ground support equipment
GSFC	Goddard Space Flight Center
GSSS	Guide Star Selection System
GSTDN	Ground Spaceflight Tracking and Data Network

-H-

HGA	High Gain Antenna
-----	-------------------

HST	Hubble Space Telescope
hyperboloidal	Slightly deeper curve, mathematically, than a parabola; shape of the primary mirror
Hz	Hertz (cycles per second)

-I-

IBM	International Business Machines Corporation
in.	Inches
interstellar	Between celestial objects; often refers to matter in space that is not a star, such as clouds of dust and gas
intravehicular	Inside the spacecraft
IOU	Input/output unit
IR	Infrared
IV	Intravehicular
IVA	Intravehicular activity

-J-

JPL	Jet Propulsion Laboratory
JSC	Johnson Space Center

-K-

k	Kilo (1000)
kB	Kilobytes
kg	Kilogram
km	Kilometer
KSC	Kennedy Space Center

-L-

Latch	Mechanical device that attaches one component, such as a science instrument, to the structure of the telescope and holds it in precisely the right place
lb	Pound
LGA	Low Gain Antenna
LGA PC	Low Gain Antenna Protective Cover
Light year	The distance traveled by light in one year, approximately six trillion miles
LMMS	Lockheed Martin Missiles & Space
LOPE	Large ORU Protective Enclosure
LOS	Line of sight
LS	Light Shield
luminosity	Intensity of a star's brightness

-M-

m	Meter
μm	Micrometer; one millionth of a meter
mm	Millimeter
MA	Multiple access
magnitude, absolute	How bright a star appears without any correction made for its distance
magnitude, apparent	How bright a star would appear if it were viewed at a standard distance
MAMA	Multi-Anode Microchannel Plate Array
MAT	Multiple Access Transponder
MCC	Mission Control Center
MCP	Microchannel plate
metrology	Process of making extremely precise measurements of the relative positions and orientations of the different optical and mechanical components

MFT	Manipulator Foot Restraint
MHz	Megahertz
MLI	Multi-layer insulation
Mpc	Megaparsec (one million parsecs)
MOPE	Multimission ORU Protective Enclosure
MSFC	Marshall Space Flight Center
MSM	Mode Selection Mechanism
MSS	Magnetic Sensing System
MT	Magnetic torquer
MTA	Metering Truss Assembly
MTS	Metering Truss Structure
M	Absolute visual magnitude
m	Apparent visual magnitude

-N-

NASA	National Aeronautics and Space Administration
NBL	Neutral Buoyancy Laboratory at JSC
NASCOM	NASA Communications Network
NCC	Network Control Center
NCS	NICMOS Cooling System
nebula	Mass of luminous interstellar dust and gas, often produced after a stellar nova
NICMOS	Near Infrared Camera and Multi-Object Spectrometer
nm	Nanometers
nmi	Nautical miles
NOBL	New Outer Blanket Layer
nova	Star that suddenly becomes explosively bright
NPE	NOBL Protective Enclosure

NSSC-I	NASA Standard Spacecraft Computer, Model-I
--------	--

-O-

occultation	Eclipsing one body with another
OCE	Optical Control Electronics
OCE-EK	OCE Enhancement Kit
OCS	Optical Control Subsystem
Orientation	Position in space relative to Earth
ORU	Orbital Replacement Unit
ORUC	Orbital Replacement Unit Carrier
OSS	Office of Space Science, NASA Headquarters
OTA	Optical Telescope Assembly

-P-

PACOR	Packet Processing Facility
parallax	Change in apparent relative orientations of objects when viewed from different positions
parsec	A distance equal to 3.26 light years
PCEA	Pointing Control Electronics Assembly
PCS	Pointing Control Subsystem
PCU	Power Control Unit
PDA	Photon Detector Assembly
PDM	Primary Deployment Mechanism
PDU	Power Distribution Unit
PFR	Portable Foot Restraint
photon	Unit of electromagnetic energy
PIP	Push in-pull out (pin)
pixel	Single picture element of a detection device
POCC	Payload Operations Control Center

polarity	Light magnetized to move along certain planes. Polarimetric observation studies the light moving along a given plane.
primary mirror	Large mirror in a reflecting telescope the size of which determines the light-gathering power of the instrument
prism	Device that breaks light into its composite wavelength spectrum
PSEA	Pointing/Safemode Electronics Assembly
PSO	HST Project Science Office at GSFC

-Q-

quasar	Quasi-stellar object of unknown origin or composition
--------	---

-R-

RAM	Random-access Memory
radial	Perpendicular to a plane (i.e., instruments placed at a 90-degree angle from the optical axis of the HST)
RBM	Radial Bay Module
RDA	Rotary Drive Actuator
reboost	To boost a satellite back into its original orbit after the orbit has decayed because of atmospheric drag
reflecting telescope	Telescope that uses mirrors to collect and focus incoming light
refracting telescope	Telescope that uses lenses to collect and focus light
resolution	Ability to discriminate fine detail in data. In an image, resolution refers to the ability to distinguish two objects very close together in space. In a spectrum, it is the ability to measure closely separated wavelengths

resolution, spectral	Determines how well closely spaced features in the wavelength spectrum can be detected
resolution, angular	Determines how clearly an instrument forms an image
RF	Radio frequency
RGA	Rate Gyro Assembly
Ritchey-Chretien	A modern optical design for two-mirror reflecting telescopes. It is a derivative of the Cassegrain concept in which the primary mirror has a hyperbolic cross-section.
RIU	Remote Interface Unit
RMGA	Retrieval Mode Gyro Assembly
RMS	Remote Manipulator System
ROM	Read-only memory
RS	Reed-Solomon
RSU	Rate Sensor Unit
RWA	Reaction Wheel Assembly

-S-

SA	Solar Array
SAA	South Atlantic Anomaly
SAC	Second Axial Carrier
SAD	Solar Array Drive
SADE	Solar Array Drive Electronics
SADM	Solar Array Drive Mechanism
SAGA	Solar Array Gain Augmentation
SBA	Secondary Baffle Assembly
SBC	Single-Board Computer
SCP	Stored Command Processor
SDAS	Science Data Analysis Software
SDM	Secondary Deployment Mechanism

secondary mirror	In a two-mirror reflecting telescope, the secondary mirror sits in front of the larger primary mirror and reflects light to the point at which it will be detected and recorded by an instrument. In simple telescopes, the secondary mirror is flat and bounces the light out the side of the tube to an eyepiece. In more complex and larger telescopes, it is convex and reflects light through a hole in the primary mirror.
Servicing Mission	NASA's plan to have the Space Shuttle retrieve the HST and have astronauts perform repairs and upgrades to equipment in space
SI	Science Instrument
SIC&DH	SI Control and Data Handling (subsystem)
SIPE	Science Instrument Protective Enclosure
SM	Secondary Mirror
SMA	Secondary Mirror Assembly
SM1	First HST Servicing Mission, December 1993
SM2	Second HST Servicing Mission, February 1997
SM3A	HST Servicing Mission 3A, December 1999
SM3B	HST Servicing Mission 3B, planned for December 2000
SOFA	Selectable Optical Filter Assembly
SOGS	Science Operations Ground System
spectral devices	These include spectrographs, instruments that photograph the spectrum of light within a wavelength range; spectrometers, which measure the position of spectral lines; and spectrophotometers, which determine energy distribution in a spectrum.
spectrograph	Instrument that breaks light up into its constituent wavelengths and allows quantitative measurements of intensity to be made spectrum

spectrum	Wavelength range of light in an image
spherical aberration	Image defect caused by a mismatch in the shapes of the reflecting surfaces of the primary and secondary mirrors. Light from different annular regions on the primary mirror comes to a focus at different distances from the secondary mirror, and there is no one position where all of the light is in focus.
SSAT	S-band Single-Access Transmitter
SSC	Science Support Center
SSE	Space Support Equipment
SSM	Support Systems Module
SSM-ES	SSM Equipment Section
SSRF	Shell-Shield Repair Fabric
STDN	Space (flight) Tracking and Data Network
STINT	Standard interface
STIS	Space Telescope Imaging Spectrograph
STOCC	Space Telescope Operations Control Center
STS	Space Transport System
STScI	Space Telescope Science Institute

-T-

TA	Translation Aids
TAG	Two-axis gimbal
TCE	Thermal Control Electronics
TCS	Thermal Control Subsystem
TDRS	Tracking and Data Relay Satellite
TDRSS	TDRS System
TECI	Thermoelectric-cooled inner (shield)
TECO	Thermoelectric-cooled outer (shield)
telemetry	Data and commands sent from the spacecraft to ground stations

TLM	Telemetry
-----	-----------

-U-

UDM	Umbilical disconnect mechanism
ULE	Ultralow expansion
USA	United States Army
USAF	United States Air Force
USN	United States Navy
UV	ultraviolet

-V-

V	Volt
V1, V2, V3	HST axes
VCS	Vapor-cooled shield
VIK	Voltage/Temperature Improvement Kit

-W-

W	Watt
Wavelength	Spectral range of light in an image
WFC	Wide Field Camera
WFPC	Wide Field and Planetary Camera. The camera currently in use is the second-generation instrument WFPC2, installed during the First Servicing Mission in December 1993. It replaced WFPC1 and was built with optics to correct for the spherical aberration of the primary mirror.

INTRODUCTION

Gazing through the first crude telescope in the 17th century, Galileo discovered the craters of the Moon, the satellites of Jupiter, and the rings of Saturn. These observations led the way to today's quest for in-depth knowledge and understanding of the cosmos. And for nearly a decade NASA's Hubble Space Telescope (HST) has continued this historic quest.

Since its launch in April 1990, Hubble has provided scientific data and images of unprecedented resolution from which many new and exciting discoveries have been made. Even when reduced to raw numbers, the accomplishments of the 12.5-ton orbiting observatory are impressive:

- Hubble has taken about 259,000 exposures.
- Hubble has observed nearly 13,000 astronomical targets.
- Astronomers using Hubble data have published over 2,400 scientific papers.
- Circling Earth every 90 minutes, Hubble has traveled about 1.425 billion miles, which is nearly the distance from Earth to Uranus.

This unique observatory operates around the clock above the Earth's atmosphere gathering information for teams of scientists who study virtually all the constituents of the universe. The Telescope is an invaluable tool for examining planets, stars, star-forming regions of the Milky Way, distant galaxies and quasars, and the tenuous hydrogen gas lying between the galaxies.

The HST can produce images of the outer planets in our solar system that approach the clarity of those from Voyager flybys. Astronomers have resolved previously unsuspected details of star-forming regions of the Orion Nebula in the Milky Way and have detected expanding gas shells blown off by exploding stars.

Using the Telescope's high-resolution and light-gathering power, scientists have calibrated the distances to remote galaxies. They have detected and measured the rotation of cool disks of matter trapped in the gravitational field at the cores of galaxies that portend the presence of massive black holes.

Spectroscopic observations at ultraviolet wavelengths inaccessible from the ground have given astronomers their first opportunity to study the abundance and spatial distribution of intergalactic hydrogen in relatively nearby regions of the universe – and forced scientists to rethink some of their earlier theories about galactic evolution. (Section 4 of this guide contains additional information on the Telescope's scientific discoveries.)

The Telescope's purpose is to spend 20 years probing the farthest and faintest reaches of the cosmos. Crucial to fulfilling this objective is a series of on-orbit manned servicing missions. The First Servicing Mission (SM1) took place in December 1993 and the Second Servicing Mission (SM2) was flown in February 1997.

During these missions, astronauts perform planned repairs and maintenance activities to restore and upgrade the observatory's capabilities. To facilitate this process, the Telescope's designers configured science instruments and several vital engineering subsystems as Orbital Replacement Units (ORU) – modular packages with standardized fittings accessible to astronauts in pressurized suits (see Fig. 1-1).

Hubble's Third Servicing Mission has been separated into two parts: Servicing Mission 3A (SM3A) will fly in October 1999 and Servicing Mission 3B (SM3B) is planned for 2001.



K70110-101

Fig. 1-1 The Hubble Space Telescope (HST) – shown in a clean room at Lockheed Martin Missiles & Space in Sunnyvale, California, before shipment to Kennedy Space Center – is equipped with science instruments and engineering subsystems designed as orbital replacement units.

The principal objective of SM3A is to replace all six gyroscopes that compose the three Rate Sensor Units (RSU). In addition, space-walking astronauts will install a new Advanced Computer that will dramatically increase the computing power, speed, and storage capability of HST. They will change out one of the Fine Guidance Sensors (FGS) and replace a

tape recorder with a new Solid State Recorder (SSR). The Extravehicular Activity (EVA) crew also will install a new S-band Single-Access Transmitter (SSAT), and Voltage/Temperature Improvement Kits (VIK) for the Telescope's nickel-hydrogen batteries. Finally, they will begin repair of the multilayer insulation on Hubble's outer surface.

During SM3B astronauts will install a new science instrument, the Advanced Camera for Surveys (ACS), and an Aft Shroud Cooling System (ASCS) for the other axial science instruments. They will attach a new cryogenic cooler to the Near-Infrared Camera and Multi-Object Spectrometer (NICMOS). They also will replace the HST flexible Solar Arrays with new high-performance rigid arrays designed and built by the Goddard Space Flight Center (GSFC), the European Space Agency (ESA) and Lockheed Martin Missiles & Space. Additionally, they will complete repair of the multilayer surface insulation begun on SM3A.

Figure 1-2 shows the SM3A activities as scheduled at press time. Section 2 provides more details of SM3A.

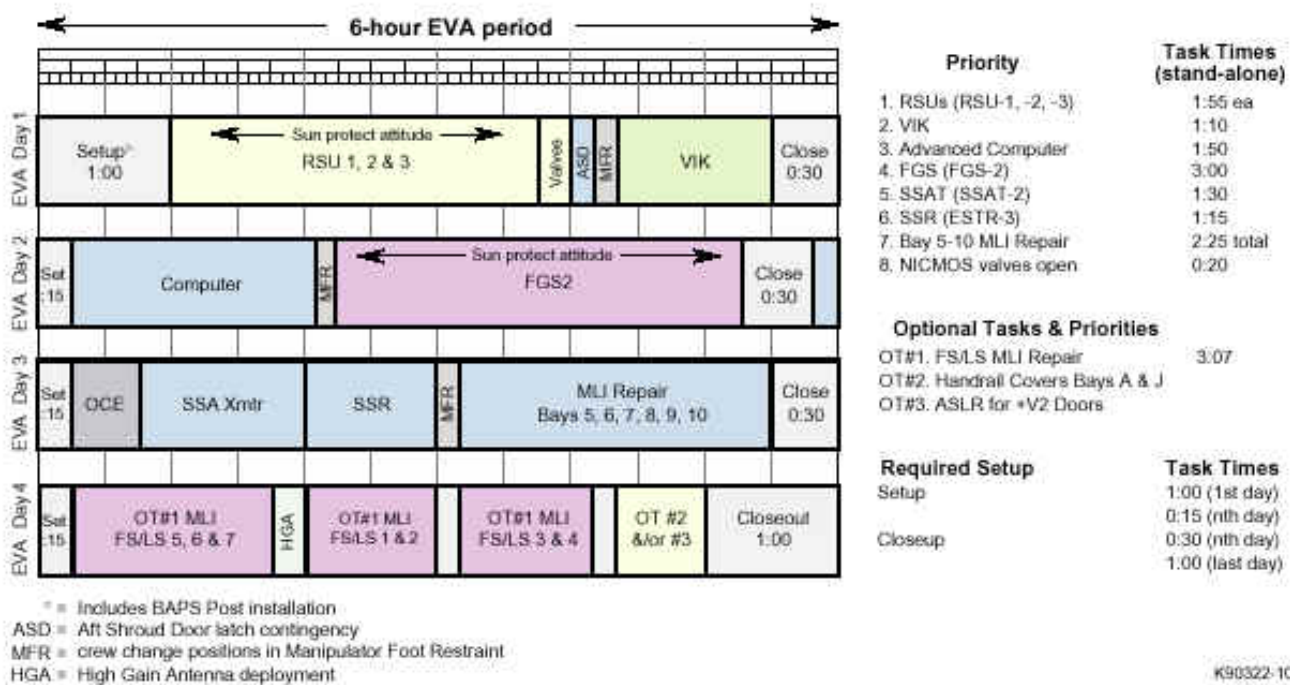
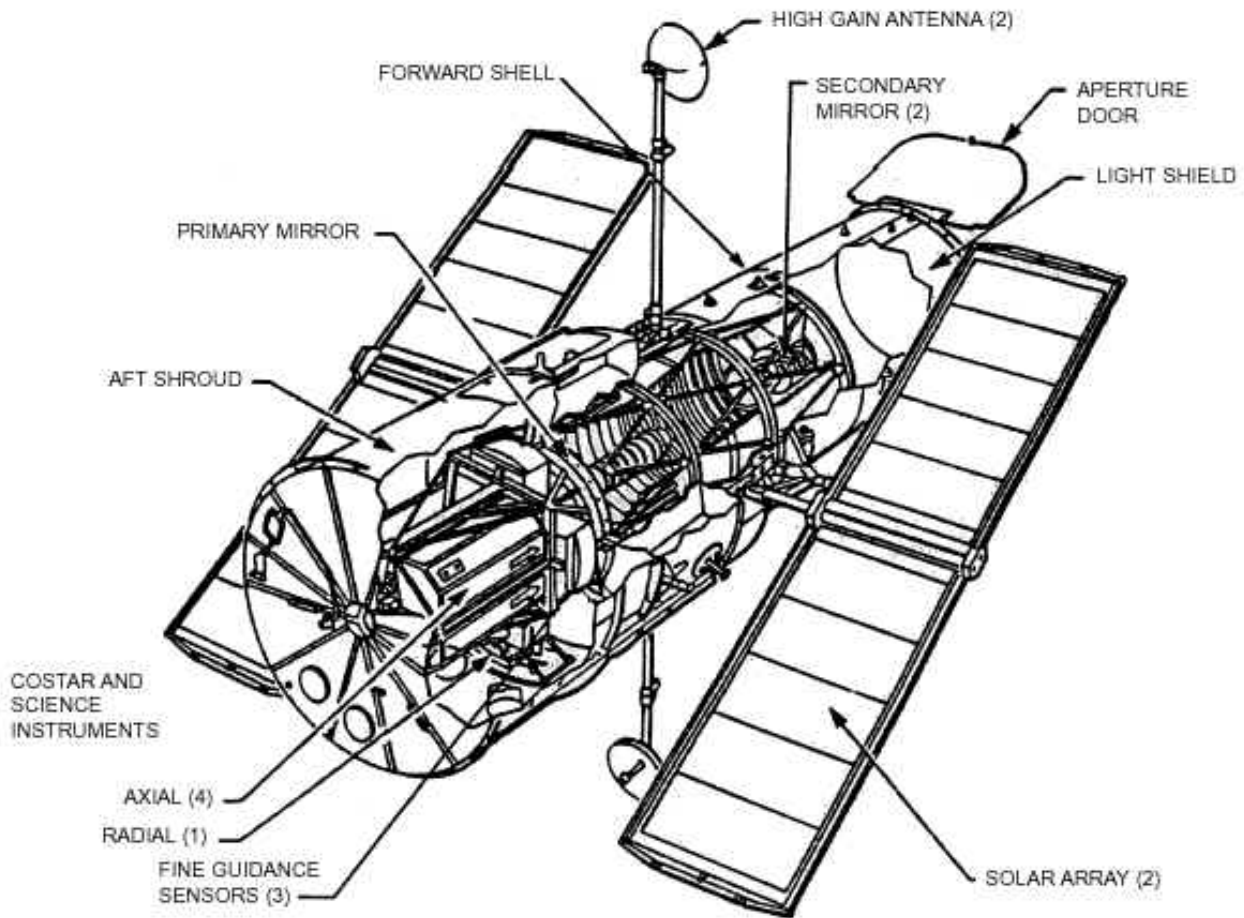

Fig. 1-2 Schedule of extravehicular activities

Since 1979 the HST team has overcome enormous technical obstacles to successfully develop and launch the orbiting observatory. The Third Servicing Mission continues this tradition. Its two challenging flights promise to upgrade the Hubble Space Telescope with the latest technology hardware for spacecraft systems and to incorporate advanced instruments that will significantly expand Hubble's scientific capabilities.

1.1 Hubble Space Telescope Configuration

Figures 1-3 and 1-4 show the overall Telescope configuration.



K70110-103

Fig. 1-3 HST overall configuration

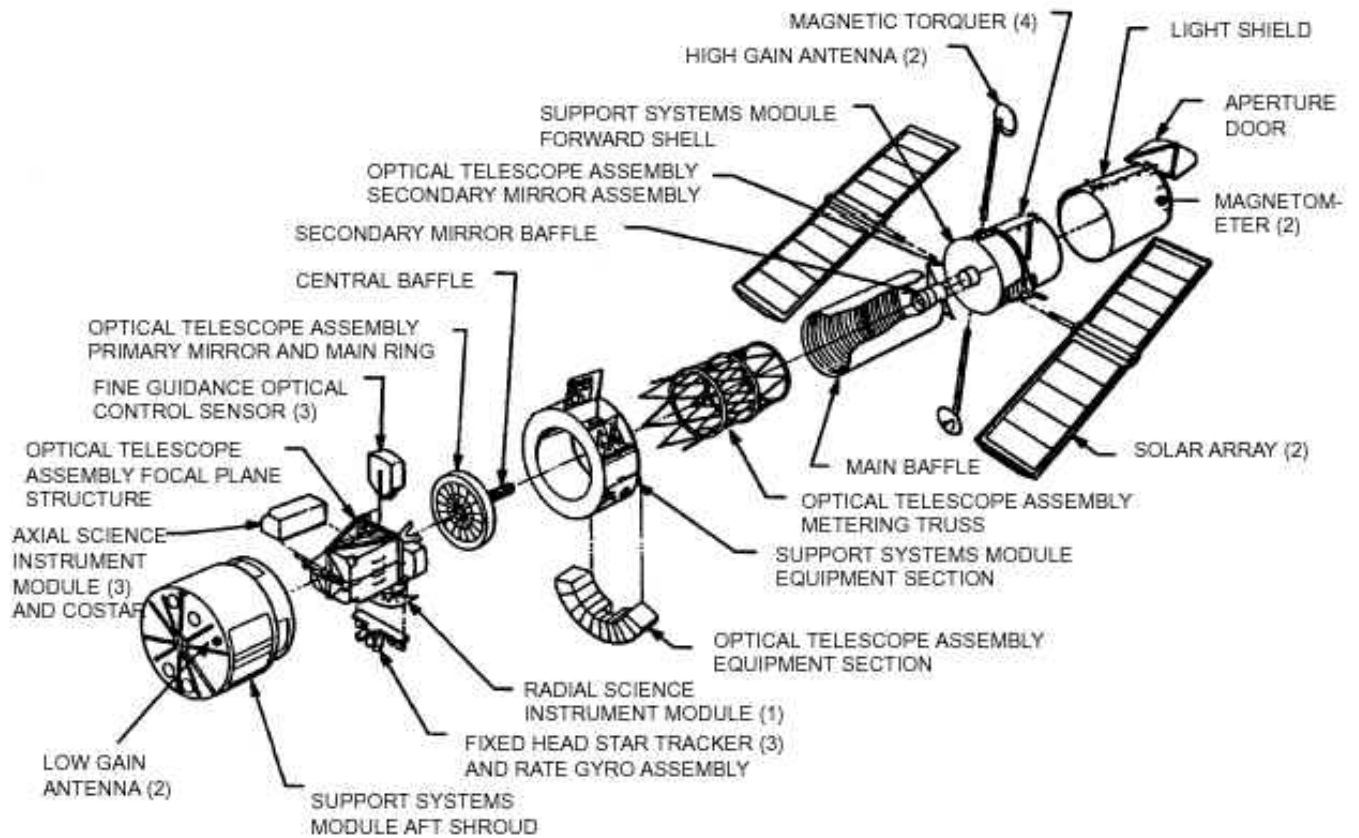

K70110-104

Fig. 1-4 HST exploded view

Figure 1-5 lists specifications for the Telescope. The major elements are:

- Optical Telescope Assembly (OTA) – two mirrors and associated structures that collect light from celestial objects
- Science instruments – devices used to analyze the images produced by the OTA
- Support Systems Module (SSM) – spacecraft structure that encloses the OTA and science instruments
- Solar Arrays (SA).

Hubble Space Telescope (HST)	
Weight	24,500 lb (11,110 kg)
Length	43.5 ft (15.9 m)
	10 ft (3.1 m) Light Shield and Forward Shell
Diameter	14 ft (4.2 m) Equipment Section and Aft Shroud
Optical system	Ritchey-Chretien design Cassegrain telescope
Focal length	189 ft (56.7 m) folded to 21 ft (6.3 m)
Primary mirror	94.5 in. (2.4 m) in diameter
Secondary mirror	12.2 in. (0.3 m) in diameter
Field of view	See instruments/sensors
Pointing accuracy	0.007 arcsec for 24 hours
Magnitude range	5 m, to 29 m, (visual magnitude)
Wavelength range	1100 to 11,000 Å
Angular resolution	0.1 arcsec at 6328 Å
Orbit	320 nmi (593 km), inclined 28.5 degrees from equator
Orbit time	97 minutes per orbit
Mission	20 years

K9322-105

Fig. 1-5 Hubble Space Telescope specifications

1.1.1 Optical Telescope Assembly

The OTA consists of two mirrors, support trusses, and the focal plane structure. The optical system is a Ritchey-Chretien design, in which two special aspheric mirrors form focused images over the largest possible field of view. Incoming light travels down a tubular baffle that absorbs stray light. The concave primary mirror – 94.5 in. (2.4 m) in diameter – collects the light and converges it toward the convex secondary mirror, which is only 12.2 in. (0.3 m) in diameter. The secondary mirror directs the still-converging light back toward the primary mirror and through a 24-in. hole in its center into the Focal Plane Structure, where the science instruments are located.

Shortly after launch in 1990, a spherical aberration of the primary mirror was detected. An investigation revealed the specific errors that caused the fault. This knowledge allowed optical experts to design and fabricate small pairs of corrective mirrors that successfully refocused the light reflected from the primary mirror before it entered the axial science instruments.

The Corrective Optics Space Telescope Axial Replacement (COSTAR) was installed on HST in December 1993. In addition, WFPC2, a radial instrument with corrective optics incorporated, was installed on the same mission. The subsequent increase in optical performance helped to restore the Telescope's capability to original expectations.

All new instruments installed after 1993 correct for spherical aberration internally within their own optical systems.

1.1.2 The Science Instruments

Hubble can accommodate eight science instruments. Four are aligned with the Telescope's main optical axis and are mounted immediately behind the primary mirror. The current suite of *axial* science instruments consists of:

- Space Telescope Imaging Spectrograph (STIS)
- Faint Object Camera (FOC) *{decommissioned}*
- Near Infrared Camera and Multi-Object Spectrometer (NICMOS) *{dormant}*
- Corrective Optics Space Telescope Axial Replacement (COSTAR) *{not currently in use}*.

In addition to the four axial instruments, four other instruments are mounted radially (perpendicular to the main optical

axis). These *radial* science instruments are:

- Wide Field and Planetary Camera 2 (WFPC2)
- Three Fine Guidance Sensors (FGS).

Space Telescope Imaging Spectrograph.

STIS separates incoming light into its component wavelengths, revealing information about the atomic composition of the light source. It can detect a broader range of wavelengths than is possible from Earth because there is no atmosphere to absorb certain wavelengths. Scientists can determine the chemical composition, temperature, pressure, and turbulence of the target producing the light – all from spectral data.

STIS also provides a two-dimensional capability to HST spectroscopy. The two dimensions can be used for "long-slit" spectroscopy, where spectra of many different points across an object are obtained simultaneously, or in a mode that obtains more wavelength coverage in a single exposure. In addition, STIS can produce visible or ultraviolet (UV) images and can provide objective prism spectra in the intermediate UV region of the spectrum. STIS also has a coronagraph capability and a high time-resolution capability in the UV. A team at GSFC manages the STIS instrument and its observations.

Wide Field and Planetary Camera 2.

WFPC2 is an electronic camera that records images at two magnifications. A team at the Jet Propulsion Laboratory (JPL) in Pasadena, California, built the first WFPC and developed the WFPC2. The team incorporated an optical correction by refiguring relay mirrors in the optical train of the cameras. Each relay mirror is polished to a prescription that compensates for the incorrect figure on HST's primary mirror. Small actuators fine-tune the positioning of these mirrors on orbit.

Fine Guidance Sensors.

The three FGSs have two functions: (1) provide data to the spacecraft's pointing system to keep HST pointed accurately at a target when one or more of the science instruments is being used to take data and (2) act as a science instrument. When functioning as a science instrument, two of the sensors lock onto guide stars and the third measures the brightness and relative positions of stars in its field of view. These measurements, referred to as astrometry, are helping to advance knowledge of the distances and motions of stars and may be useful in detecting planetary-sized companions of other stars.

1.1.3 Support Systems Module

The SSM encloses the OTA and the science instruments like the dome of an Earth-based observatory. It also contains all of the structures, mechanisms, communications devices, electronics, and electrical power subsystems needed to operate the Telescope.

This module supports the light shield and an aperture door that, when opened, admits light. The shield connects to the forward shell on which the SAs and High Gain Antennas (HGA) are mounted. Electrical energy from the 40-ft (12-m) SAs charges the spacecraft batteries to power all HST systems. Four antennas, two high-gain and two low-gain, send and receive information between the Telescope and the Space Telescope Operations Control Center (STOCC). All commanding occurs through the Low Gain Antennas (LGA).

Behind the OTA is the Equipment Section, a ring of bays that house the batteries and most of the electronics, including the computer and communications equipment. At the rear of the Telescope, the aft shroud contains the science instruments.

1.1.4 Solar Arrays

The SAs provide power to the spacecraft. They are mounted like wings on opposite sides of the Telescope, on the forward shell of the SSM. Each array stands on a mast that supports a retractable wing of solar panels 40 ft (12.2 m) long and 8.2 ft (2.5 m) wide.

The SAs are rotated so each wing's solar cells face the Sun. The cells absorb the Sun's light energy and convert it into electrical energy to power the Telescope and charge the spacecraft's batteries, which are part of the Electrical Power Subsystem (EPS). Batteries are used when the Telescope moves into Earth's shadow during each orbit.

Shortly after launch in 1990, it was determined that as the Telescope orbited in and out of direct sunlight, the resulting thermal gradients caused oscillation of the SAs, inducing jitter in the Telescope's line of site. This in turn caused some loss of fine lock of the FGSs during science observations. New SAs with thermal shields over the array masts installed during SM1 minimized the effect.

1.1.5 Computers

Hubble's Data Management Subsystem (DMS) contains two computers: the DF-224 flight computer and the Science Instrument Control and Data Handling (SI C&DH) unit. The DF-224 performs onboard computations and handles data and command transmissions between the Telescope systems and the ground system. The SI C&DH unit controls commands received by the science instruments, formats science data, and sends data to the communications system for transmission to Earth.

During SM1 astronauts installed a coprocessor to augment the DF-224 capacity. The new 386- co-processor increased flight computer redundancy and significantly enhanced on-orbit computational capability.

During SM3A astronauts will replace the DF-224 and its co-processor with an Advanced Computer. It will assume all of the DF-224 functions while running 20 times faster and providing six times as much onboard memory.

1.2 The Hubble Space Telescope Program

Hubble Space Telescope represents the fulfillment of a 50-year dream and 23 years of dedicated scientific effort and political vision to advance humankind's knowledge of the universe.

The HST program comprises an international community of engineers, scientists, contractors, and institutions. It is managed by GSFC for the Office of Space Science (OSS) at NASA Headquarters.

The program falls under the Search for Origins and Planetary Systems scientific theme. Within GSFC, the program is in the Flight Projects Directorate, under the supervision of the associate director of Flight Projects for HST.

The HST program is organized as two flight projects: (1) the HST Operations and Ground Systems Project and (2) the HST Flight Systems and Servicing Project.

Responsibilities for scientific oversight on HST are divided among the members of the Project Science Office (PSO). The PSO is designed to interact effectively and efficiently with the HST flight project and the wide range of external organizations involved with the HST. The senior scientist for the HST and supporting staff work in the Office of the Associate Director of Flight Projects for HST. This group is concerned with the highest level of scientific management for the project.

The roles of NASA centers and contractors for on-orbit servicing of the HST are:

- Goddard Space Flight Center (GSFC) – Overall management of daily on-orbit operations of HST and the development, integration, and test of replacement hardware, space support equipment, and crew aids and tools

- Johnson Space Center (JSC) – Overall servicing mission management, flight crew training, and crew aids and tools
- Kennedy Space Center (KSC) – Overall management of launch and post-landing operations for mission hardware
- Ball Aerospace – Design, development, and provision of axial science instruments
- JPL – Design, development, and provision of WFPC1 and WFPC2
- Lockheed Martin – personnel support for GSFC to accomplish (1) development, integration, and test of replacement hardware and space support equipment; (2) system integration with the Space Transportation System (STS); (3) launch and post-landing operations; and (4) daily HST operations.

Major subcontractors for SM3A include Raytheon Optical Systems, Inc., Allied Signal, Jackson and Tull, Orbital Sciences Corporation, Odetics, Honeywell, ETA, and Hughes STX.

The HST program requires a complex network of communications among GSFC, the Telescope, Space Telescope Ground System, and the Space Telescope Science Institute.

Figure 1-6 summarizes the major organizations that oversee the program. Figure 1-7 shows communication links.

Organization	Function
NASA Headquarters	<ul style="list-style-type: none"> • Provides overall responsibility for the program
Goddard Space Flight Center – Office of the Associate Director of Flight Projects for HST – HST Operations and Ground Systems Project	<ul style="list-style-type: none"> • Overall HST Program Management • HST Project Management • Responsible overseeing all HST operations
Space Telescope Operations Control Center	<ul style="list-style-type: none"> • Provides minute-to-minute spacecraft control • Schedules, plans, and supports all science operations when required • Monitors telemetry communications data to the HST
Space Telescope Science Institute	<ul style="list-style-type: none"> • Selects observing programs from numerous proposals • Analyzes astronomical data
Goddard Space Flight Center – HST Flight Systems and Servicing Project	<ul style="list-style-type: none"> • Responsible for implementing HST Servicing Program • Manages development of new HST spacecraft hardware and service instruments • Manages HST Servicing Payload Integration and Test Program • Primary interface with the Space Shuttle Program at JSC

K70110-108

Fig. 1-6 Organization summary for HST program operational phase

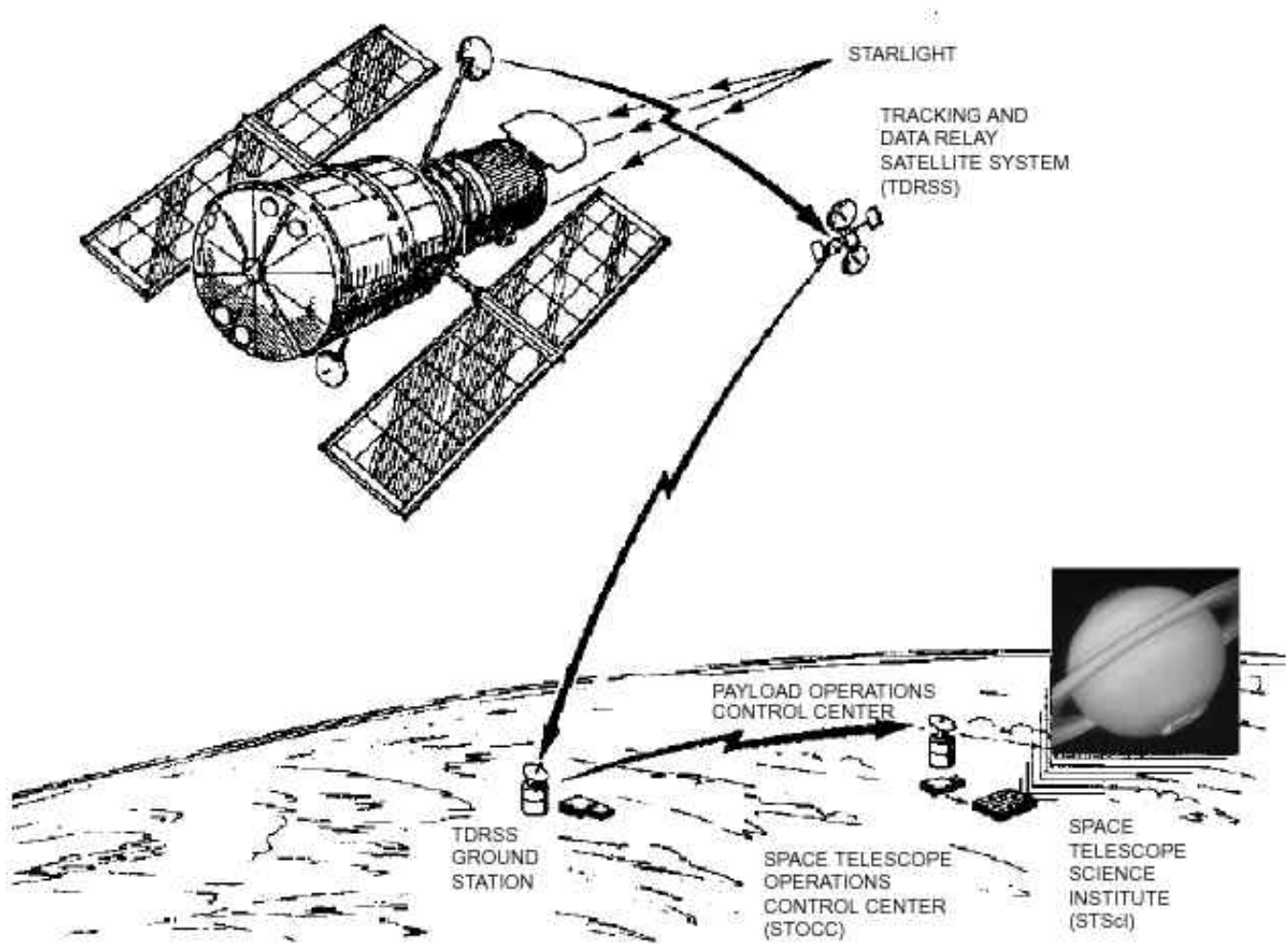

Fig. 1-7 HST data collecting network

1.3 The Value of Servicing

Hubble's visionary modular design allows NASA to equip it with new, state-of-the-art instruments every few years. These servicing missions enhance the Telescope's science capabilities, leading to fascinating new discoveries about the universe. Periodic service calls also permit astronauts to "tune up" the Telescope and replace limited-life components.

HUBBLE SPACE TELESCOPE SERVICING MISSION 3A

The Hubble Space Telescope (HST) is the first observatory designed for extensive maintenance and refurbishment in orbit. While other U.S. spacecraft have been retrieved or repaired by astronauts, none was so thoroughly designed for orbital servicing as HST. Its science instruments and many other components were designed as Orbital Replacement Units (ORU) – modular in construction with standardized fittings and accessible to spacewalking astronauts. Features such as handrails and foot restraints are built into the Telescope to help astronauts perform servicing tasks in the Shuttle cargo bay as they orbit Earth at 17,500 mph.

For Servicing Mission 3A (SM3A), the *Discovery* cargo bay is equipped with several devices to help the astronauts. The Flight Support System (FSS) will berth and rotate the Telescope. Large, specially designed equipment containers house the ORUs. Astronauts can work and be maneuvered as needed from the Shuttle robot arm.

SM3A will benefit from lessons learned on NASA's previous on-orbit servicing missions, ranging from the 1984 Solar Maximum repair mission to the 1993 HST First Servicing Mission (SM1) and the 1997 Second Servicing Mission (SM2). NASA has incorporated these lessons in detailed planning and training sessions for astronauts Curtis Brown, Jr., Scott Kelly, Jean-François Clervoy, Steven Smith, John Grunsfeld, Michael Foale, and Claude Nicollier. All of NASA's planning and the astronauts' skills will be put to the test during the SM3A mission in October. Four extravehicular activity (EVA) days are scheduled for the servicing.

2.1 Reasons for Orbital Servicing

The Hubble Telescope is a national asset and an invaluable international scientific resource that has revolutionized modern astronomy. To achieve its full potential, HST will continue to conduct extensive, integrated scientific observations, including follow-up work on its many discoveries.

Although the Telescope has numerous redundant parts and safemode systems, such a complex spacecraft cannot be designed with sufficient backups to handle every contingency likely to occur during a 20-year mission. Orbital servicing is the key to keeping Hubble in operating condition. NASA's orbital servicing plans address three primary maintenance scenarios:

- Incorporating technological advances into the science instruments and ORUs
- Normal degradation of components
- Random equipment failure or malfunction.

Technological Advances.

Throughout the Telescope's 20-year life, scientists and engineers will upgrade the science instruments. For example, when Hubble was launched in 1990, it was equipped with the Goddard High Resolution Spectrograph and the Faint Object Spectrograph. A second-generation instrument, the Space Telescope Imaging Spectrograph, took over the function of those two instruments – and added considerable new capability – when it was installed during the Second Servicing Mission in February 1997. This left open a slot for the Near Infrared Camera and Multi-Object Spectrometer (NICMOS), which expanded the Telescope's vision into the infrared region of the spectrum. Additionally, on SM2 a new Solid State Recorder (SSR) replaced an Engineering/Science Tape Recorder (E/STR).

Component Degradation.

Servicing plans take into account the need for routine replacement of some items, for example, restoring HST system redundancy and limited-life items such as tape recorders and gyroscopes.

Equipment Failure.

Given the enormous scientific potential of the Telescope – and the investment in designing, developing, building, and putting it into orbit – NASA must be able to correct unforeseen problems that arise from random equipment failures or malfunctions. The Space Shuttle program provides a proven system for transporting astronauts to the Telescope fully trained for its on-orbit servicing.

Originally, planners considered using the Shuttle to return the Telescope to Earth approximately every five years for maintenance. However, the idea was rejected for both technical and economic reasons. Returning Hubble to Earth would entail a significantly higher risk of contaminating or damaging delicate components. Ground servicing would require an expensive clean room and support facilities,

including a large engineering staff, and the Telescope would be out of action for a year or more – a long time to suspend scientific observations.

Shuttle astronauts can accomplish most maintenance and refurbishment within a 10-day on-orbit mission – with only a brief interruption to scientific operations and without the additional facilities and staff needed for ground servicing.

2.2 Orbital Replacement Units

Advantages of ORUs include modularity, standardization, and accessibility.

Modularity.

Engineers studied various technical and human factors criteria to simplify Telescope maintenance. Due to the limited time available for repairs and the astronauts' limited visibility, mobility, and dexterity in the EVA environment, designers simplified the maintenance tasks by planning entire components for replacement.

The modular ORU concept is key to successfully servicing the Telescope on orbit. ORUs are self-contained boxes installed and removed using fasteners and connectors. They range from small fuses to phone-booth-sized science instruments weighing more than 700 lb (318 kg). Figure 2-1 shows the ORUs for SM3A.

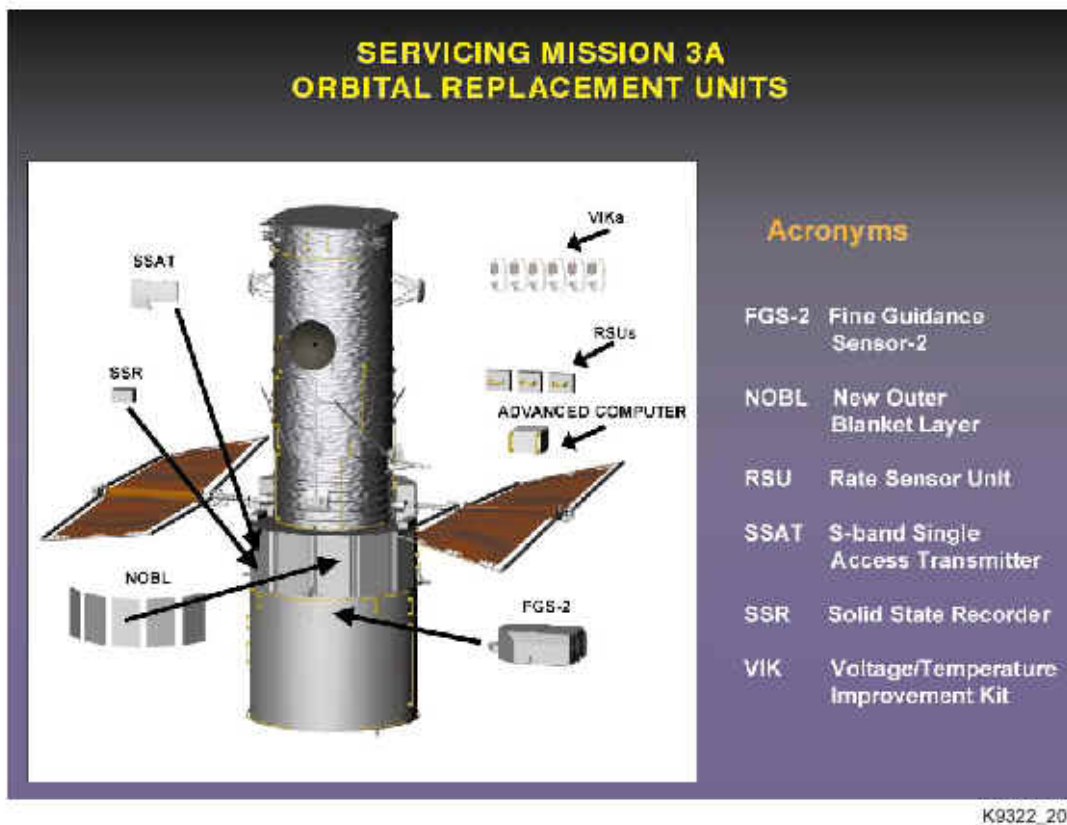

Fig. 2-1 Hubble Space Telescope Servicing Mission 3A Orbital Replacement Units

Standardization.

Standardized bolts and connectors also simplify on-orbit repairs. Captive bolts with 7/16-in., double-height hex heads hold many ORU components in place. To remove or install the bolts, astronauts need only a 7/16-in. socket fitted to a power tool or manual wrench. Standardization limits the number of crew aids and tools.

Some ORUs do not contain these fasteners. When the maintenance philosophy changed from Earth-return to on-orbit-only servicing, other components were selected as replaceable units after their design had matured. This added a greater variety of fasteners to the servicing requirements, including non-captive 5/16-in.-head bolts and connectors without wing tabs. Despite these exceptions, the high level of standardization among units reduces the number of tools needed for the servicing mission and simplifies astronaut training.

Accessibility.

To be serviced in space, Telescope components must be seen and reached by an astronaut in a bulky pressure suit, or they must be within range of the appropriate tool. Therefore, most ORUs are mounted in equipment bays around the perimeter of the spacecraft. To access these units, astronauts simply open a large door that covers the appropriate bay.

Handrails, foot restraint sockets, tether attachments, and other crew aids are essential to efficient, safe on-orbit servicing. In anticipation of servicing missions, 31 foot restraint sockets and 225 ft of handrails were designed into the Telescope. The foot restraint sockets and handrails greatly increase the mobility and stability of EVA astronauts, giving them safe worksites conveniently located near ORUs.

Crew aids such as portable lights, special tools, installation guiderails, handholds, and portable foot restraints (PFR) also ease servicing of the telescope components. In addition, foot restraints, translation aids and handrails are built into various equipment and instrument carriers specific to each servicing mission.

2.3 Shuttle Support Equipment

To assist the astronauts in servicing the Telescope, *Discovery* will carry into orbit several thousand pounds of hardware and Space Support Equipment (SSE), including the Remote Manipulator System (RMS), FSS, and ORU Carrier (ORUC).

2.3.1 Remote Manipulator System

The *Discovery* RMS, also known as the robotic arm, will be used extensively during SM3A. The astronaut operating this device from inside the cabin is designated intravehicular activity (IVA) crew member. The RMS will be used to:

- Capture, berth, and release the Telescope
- Transport new components, instruments, and EVA astronauts between worksites
- Provide a temporary work platform for one or both EVA astronauts.

2.3.2 Space Support Equipment

Ground crews will install two major assemblies essential for SM3A – the FSS and ORUC – in *Discovery*'s cargo bay. Figure 2-2 shows a cargo bay view of these assemblies.

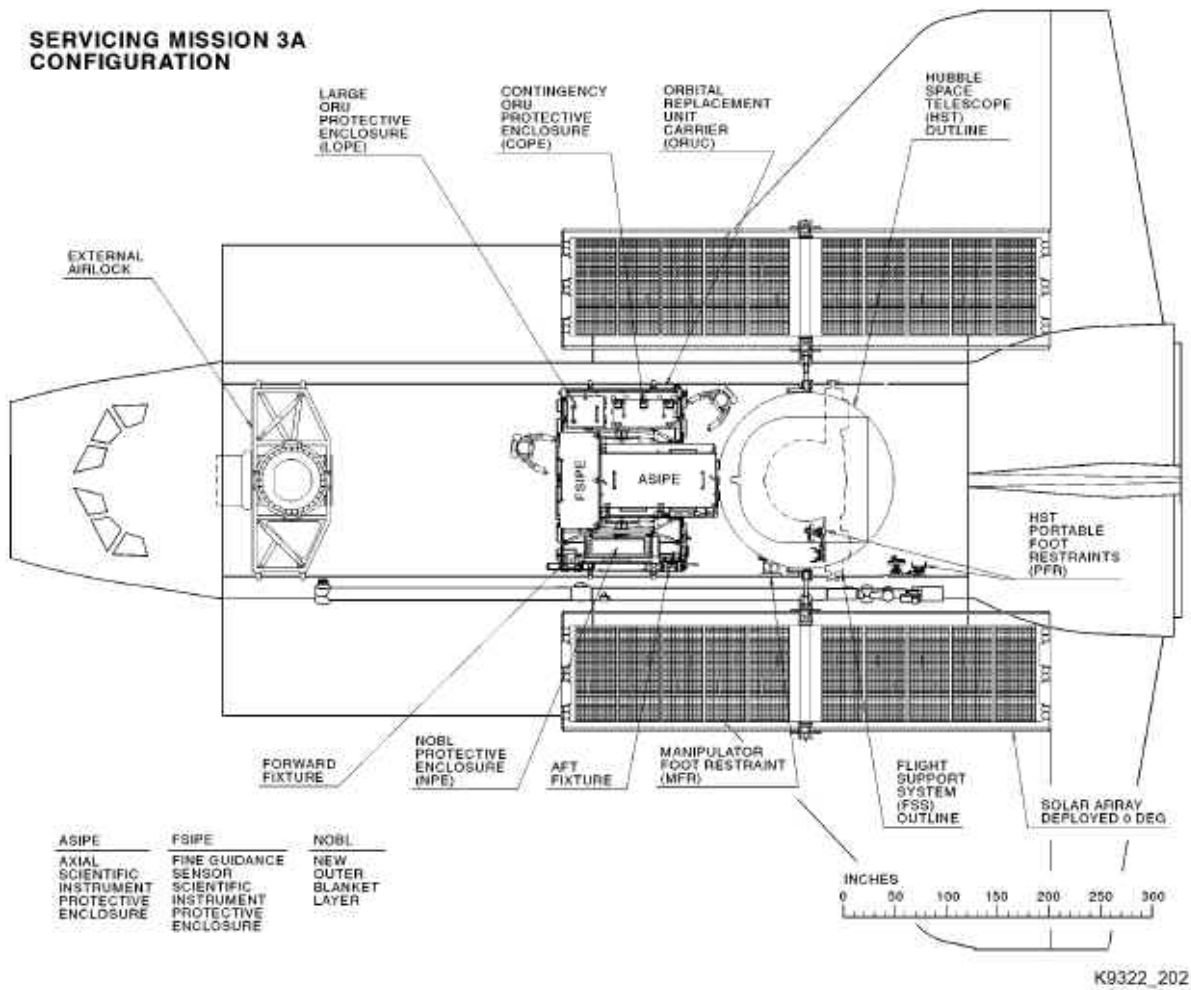

Fig. 2-2 Servicing Mission 3A Payload Bay configuration

Flight Support System.

The FSS is a maintenance platform used to berth the HST in the cargo bay after the *Discovery* crew has rendezvoused with and captured the Telescope (see Fig. 2-3). The platform was adapted from the FSS first used during the 1984 Solar Maximum repair mission. It has a U-shaped cradle that spans the rear of the cargo bay. A circular berthing ring with three latches secures the Telescope to the cradle. The berthing ring can rotate the Telescope almost 360 degrees (176 degrees clockwise or counterclockwise from its null position) to give EVA astronauts access to every side of the Telescope.

The FSS also pivots to lower or raise the Telescope as required for servicing or reboosting. The FSS's umbilical cable provides power from *Discovery* to maintain thermal control of the Telescope and permits ground engineers to test and monitor Telescope systems during the servicing mission.

FSS – AFT VIEW

AMSB: Advanced Mechanism Selection Box
CEP: Contamination Environment Package
CMP: Contamination Monitoring Package
EPDSU: Enhanced Power Distribution & Switching Unit
IPCU: Interface Power Control Unit
PDSU: Power Distribution & Switching Unit
PCU: Port Power Conditioning Unit
SIP: Standard Interface Panel
SPCU: Starboard Power Conditioning Unit

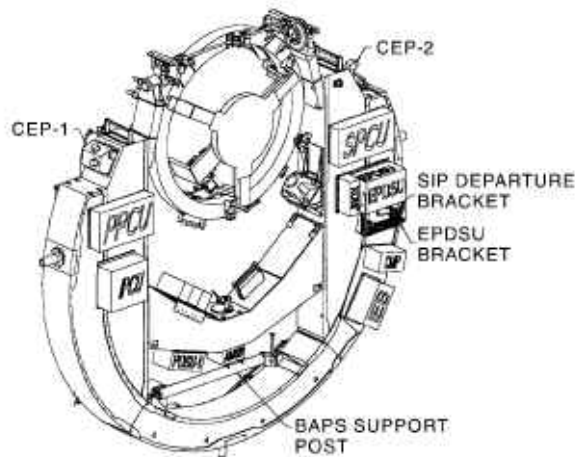

K9322_203

Fig 2-3 Flight Support System configuration

2.3.3 Orbital Replacement Unit Carrier

The ORUC is centered in *Discovery*'s cargo bay. A Spacelab pallet modified with a shelf, it has provisions for safe transport of ORUs to and from orbit (see Fig. 2-4). In the SM3A configuration:

- The Fine Guidance Sensor (FGS) #2 is stored in the Fine Guidance Sensor Scientific Instrument Protective Enclosure (FSIPE).
- The Large ORU Protective Enclosure (LOPE) contains the Advanced Computer and two Y-harnesses (going up), two spare Voltage/Temperature Improvement Kits (VIK), and the DF-224 computer and co-processor (returning from orbit).
- The Contingency ORU Protective Enclosure (COPE) houses three Rate Sensor Units (RSU), the Solid State Recorder (SSR) (going up), the S-band Single Access Transmitter (SSAT), the Engineering/Science Tape Recorder (E/STR) (coming back), and additional harnesses. Contingency hardware including the Electronics Control Unit (ECU), the spare Optics Control Electronics Enhancement Kit (OCE/EK), and the Power Distribution Unit (PDU) connector covers are stowed in the COPE.
- Connector converters for the Advanced Computer are on the COPE lid.
- The Axial Scientific Instrument Protective Enclosure (ASIPE) shelf contains the spare Advanced Computer, the spare RSU, six Multi-Layer Insulation (MLI) patches (two large and four small), seven Shell/Shield Replacement Fabrics (SSRFs), and six SSRF rib clamps.
- The New Outer Blanket Layer (NOBL) Protective Enclosure (NPE) contains the new protective coverings to be installed on the Telescope equipment bay doors.
- The Auxiliary Transport Module (ATM) houses MLI Recovery Bags, the Data Management Unit (DMU)/Advanced Computer contingency cables, a debris bag, and a spare SSAT coaxial cable. The protective enclosures, their heaters, and thermal insulation control the temperature of the new ORUs and provide an environment equivalent to that inside the Telescope. Struts, springs, and foam between the enclosures and the pallet protect the ORUs from the loads generated at liftoff and during Earth return.

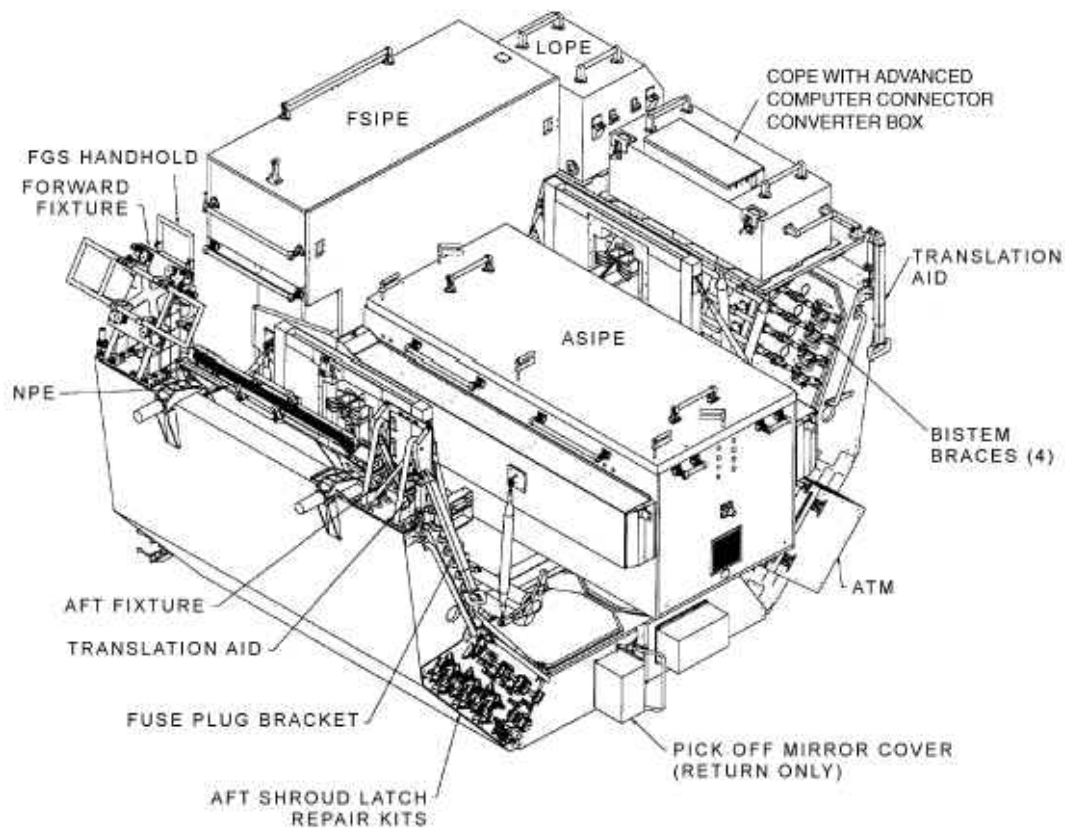

K9322_204

Fig. 2-4 Orbital Replacement Unit Carrier

2.4 Astronaut Roles and Training

To prepare for SM3A, the seven-member *Discovery* crew trained extensively at NASA's Johnson Space Center (JSC) in Houston, Texas, and Goddard Space Flight Center (GSFC) in Greenbelt, Maryland.

Although there has been extensive cross training, each crewmember also has trained for specific tasks. Training for Mission Commander Brown and Pilot Kelly focused on rendezvous and proximity operations, such as retrieval and deployment of the Telescope. The two astronauts rehearsed these operations using JSC's Shuttle Mission Simulator, a computer-supported training system. In addition, they received IVA training – helping the EVA astronauts into suits and monitoring their activities outside the *Discovery* cabin.

The five Mission Specialists also received specific training, starting with classroom instruction on the various ORUs, tools and crew aids, Space Support Equipment (SSE) such as the RMS (the robotic arm), and the FSS. Principal operator of the robotic arm is Mission Specialist Clervoy, who also performs IVA duties. The alternate operators are mission specialists Claude Nicollier and John Grunsfeld.

Clervoy trained specifically for capture and redeployment of the Telescope, rotation and pivoting of the Telescope on the FSS, and related contingencies. These operations were simulated with JSC's Manipulator Development Facility, which includes a mockup of the robotic arm and a suspended helium balloon with dimensions and grapple fixtures similar to those on the Telescope. RMS training also took place at JSC's Neutral Buoyancy Laboratory (NBL), enabling the RMS operator and alternates to work with individual team members. For hands-on HST servicing, EVA crewmembers work in teams of two in the cargo bay. Astronauts Smith, Grunsfeld, Foale, and Nicollier logged many days of training for this important role in the NBL, a 40-ft (12-m)-deep water tank (see Fig. 2-5).

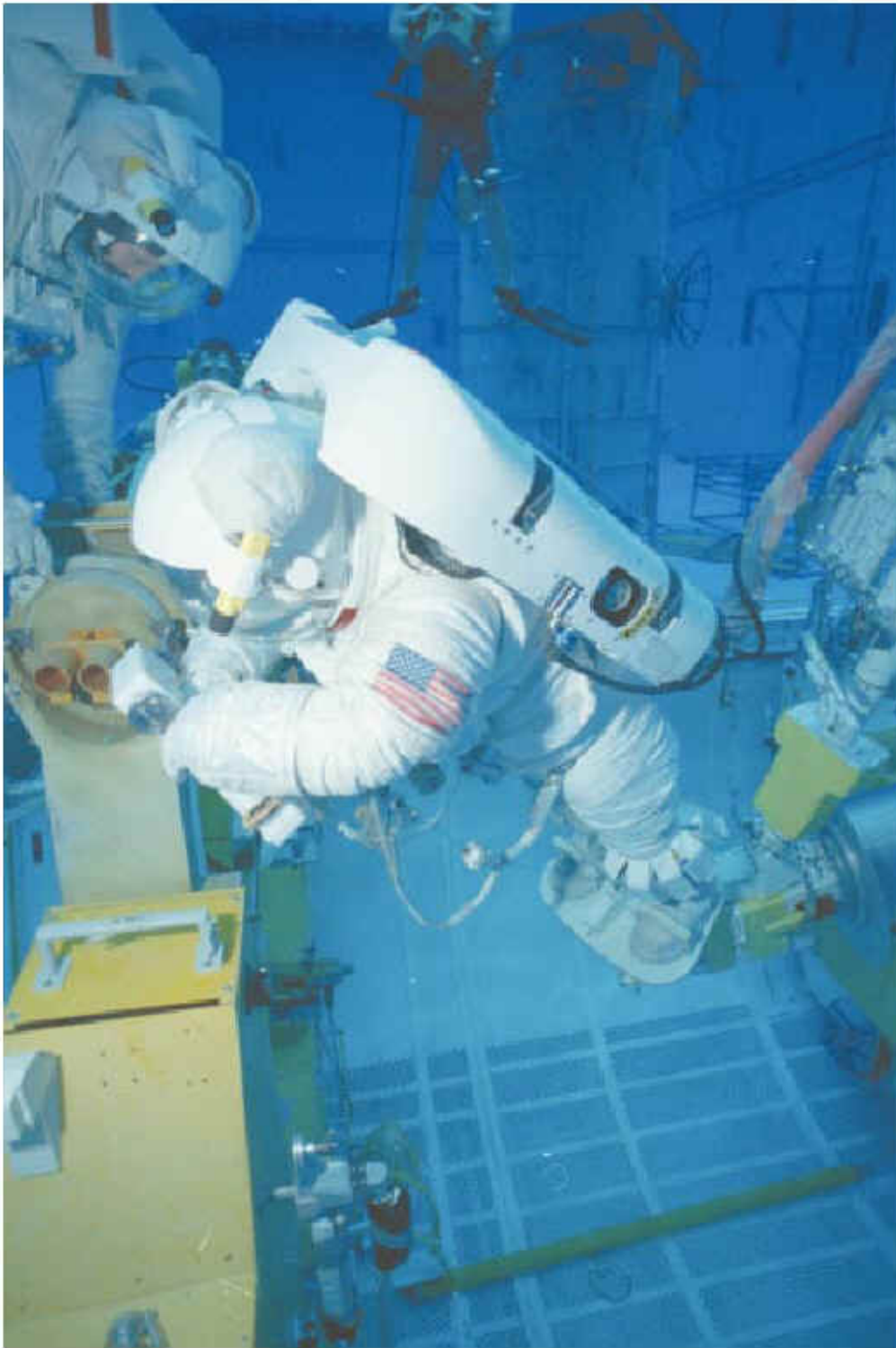

K9322_205

Fig. 2-5 Neutral Buoyancy Laboratory at NASA Johnson Space Center

In the NBL, pressure-suited astronauts and their equipment are made neutrally buoyant, a condition that simulates weightlessness. Underwater mockups of the Telescope, FSS, ORUs, ORUC, RMS, and the Shuttle cargo bay enabled the astronauts to practice entire EVA servicing. Such training activities help the astronauts efficiently use the limited number of days (four) and duration (six hours) of each EVA period during the servicing mission.

Other training aids at JSC helped recreate orbital conditions for the *Discovery* astronauts. In the weightlessness of space, the tiniest movement can set instruments weighing several hundred pounds, such as FGS #2, into motion.

To simulate the delicate on-orbit conditions, models of the instruments are placed on pads above a stainless steel floor and floated on a

thin layer of pressurized gas. This allows crewmembers to practice carefully nudging the instruments into their proper locations.

Astronauts also used virtual reality technologies in their training. This kind of ultrarealistic simulation enabled the astronauts to "see" themselves next to the Telescope as their partners maneuver them into position with the robotic arm.

2.5 Extravehicular Crew Aids and Tools

Astronauts servicing HST use three different kinds of foot restraints to counteract their weightless environment. When anchored in a Manipulator Foot Restraint (MFR), an astronaut can be transported from one worksite to the next with the RMS. Using either the STS or HST PFR, an astronaut establishes a stable worksite by mounting the restraint to any of 31 different receptacles strategically placed on the Telescope or 16 receptacles on the ORUC and the FSS.

In addition to foot restraints, EVA astronauts have more than 150 tools and crew aids at their disposal. Some of these are standard items from the Shuttle's toolbox, while others are unique to this servicing mission. All tools are designed to be used in a weightless environment by astronauts wearing pressurized gloves.

The most commonly used ORU fasteners are those with 7/16-in., double-height hex heads. These bolts are used with three different kinds of fittings: J-hooks, captive fasteners, and keyhole fasteners. To replace a unit, the astronauts use a 7/16-in. extension socket on a powered or manual ratchet wrench. Extensions up to 2 ft long are available to extend an astronaut's reach. Multi-setting torque-limiters prevent over-tightening of fasteners or latch systems.

For units with bolts or screws that are not cap-tive in the ORU frame, astronauts use tools fitted with socket capture fittings – and specially designed capture tools – so that nothing floats away in the weightless space environment. To grip fasteners in hard-to-reach areas, the crew can use wobble sockets.

Some ORU electrical connectors require special tools, such as a torque tool to loosen coaxial connectors. If connectors have no wing tabs, astronauts use another special tool to get a firm hold on the rotating ring of the connector.

Portable handles have been attached to many larger ORUs to facilitate removal or installation. Other tools and crew aids used during the servicing mission are tool caddies (carrying aids), tethers, transfer bags, and protective covers for the Low Gain Antenna (LGA).

When astronauts work within the Telescope's aft shroud area, they must guard against optics contamination by using special tools that will not outgas or shed particulate matter. All tools are certified to meet this requirement.

2.6 Astronauts of the Servicing Mission 3A

NASA carefully selected and trained the SM3A STS-103 crew (see Fig. 2-6). Their unique set of experiences and capabilities makes them eminently qualified for this challenging assignment.

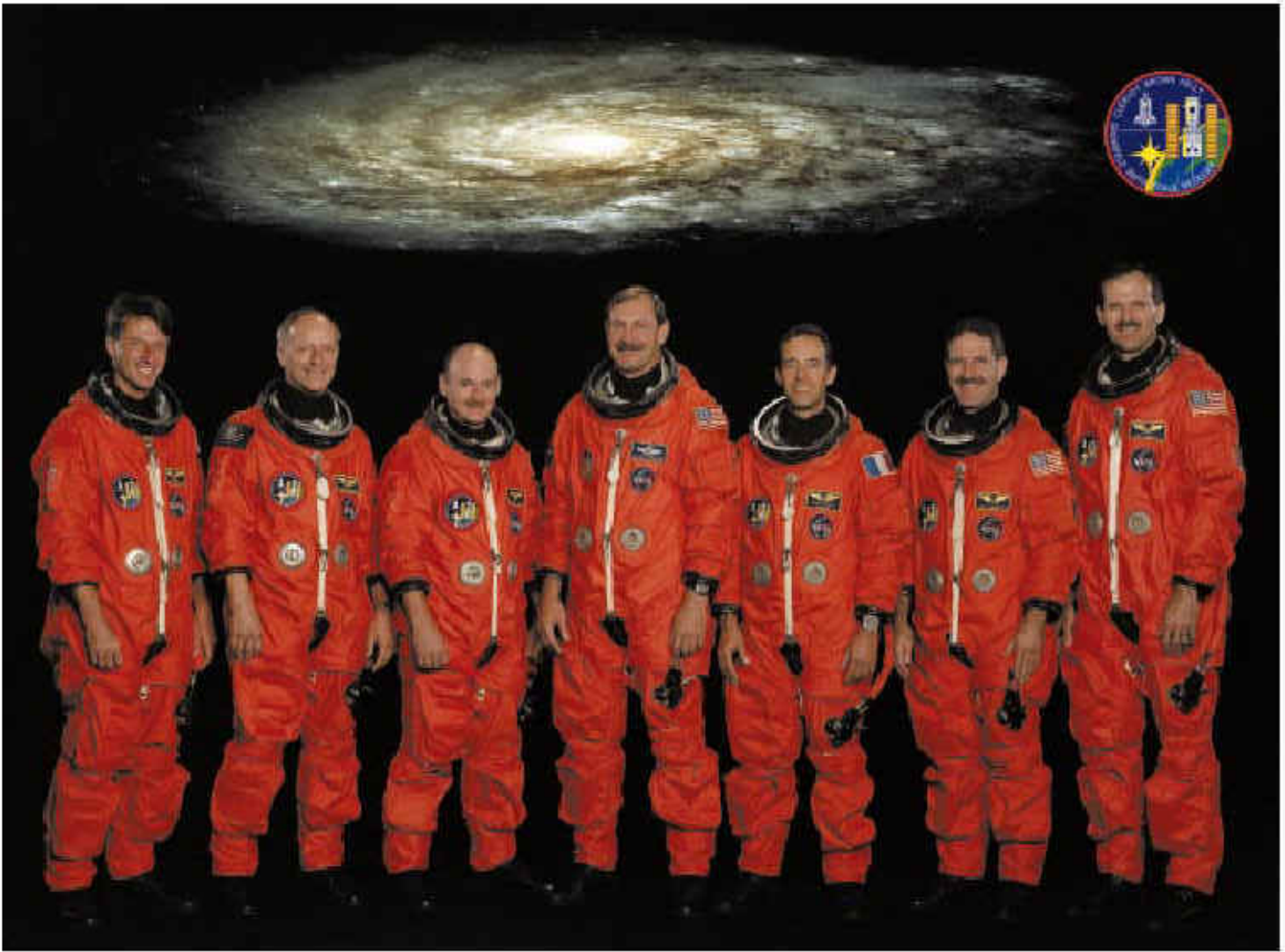

K9322_206

Fig. 2-6 The STS-103 mission has seven crewmembers. They are (from left) Mission Specialist C. Michael Foale, Mission Specialist Claude Nicollier, Pilot Scott J. Kelly, Commander Curtis L. Brown, Jr., Mission Specialist Jean-François Clervoy, Mission Specialist John M. Grunsfeld, and Mission Specialist and Payload Commander Steven L. Smith.

Brief biographies of the STS-103 astronauts follow.

Curtis L. Brown, Jr., NASA Astronaut (Lieutenant Colonel, USAF). Curtis Brown of Elizabethtown, North Carolina, is commander of SM3A. He received a bachelor of science degree in electrical engineering from the Air Force Academy in 1978. His career highlights include: 1992 – pilot of STS-47 Spacelab-J, an eight-day cooperative mission between the United States and Japan; 1994 – pilot of STS-66, the Atmospheric Laboratory for Applications and Science-3 (ATLAS-3) mission; 1996 – pilot of STS-77, whose crew performed a record number of rendezvous sequences (one with a SPARTAN satellite and three with a deployed Satellite Test Unit) and approximately 21 hours of formation flying in close proximity of the satellites; 1997 – commander of STS-85, a 12-day mission that included deployment and retrieval of the CRISTA-SPAS payload; 1998 – commander of STS-95, a nine-day mission during which the crew supported a variety of research payloads including the Hubble Space Telescope Orbital Systems Test Platform and deployment of the Spartan solar-observing spacecraft.

Scott J. Kelly, NASA Astronaut (Lieutenant Commander, USN). Scott Kelly, *Discovery* pilot on SM3A, is from Orange, New Jersey. He received a bachelor of science degree in electrical engineering from the State University of New York Maritime College in 1987 and a master of science degree in aviation systems from the University of Tennessee, Knoxville, in 1996. Kelly became a naval aviator in 1989 and served in the North Atlantic, Mediterranean Sea, Red Sea and Persian Gulf. He graduated from the U.S. Naval Test Pilot School in 1994, then worked as a test pilot, logging over 2,000 flight hours in more than 30 different aircraft. After completing two years of training and evaluation at Johnson Space Center in 1998, he qualified for flight assignment as a pilot. Before his selection for the SM3A crew, Kelly performed technical duties in the Astronaut Office Spacecraft Systems/Operations Branch.

Jean-François Clervoy, ESA Astronaut. Jean-François Clervoy, the RMS operator on SM3A, is from Toulouse, France. Clervoy

received his baccalauréat from Collège Militaire de Saint Cyr l' Ecole in 1976 and graduated from Ecole Polytechnique, Paris, in 1981. He was selected as a French astronaut in 1985 and became a flight test engineer in 1987. Clervoy served as chief test director of the Parabolic Flight Program at the Flight Test Center, Brétigny-sur-Orge, where he was responsible for testing and qualifying the Caravelle aircraft for microgravity. He also worked at the Hermes Crew Office, Toulouse, supporting the European Manned Space Programs. Clervoy trained in Star City, Moscow, on the Soyuz and Mir systems in 1991. He was selected for the astronaut corps of the European Space Agency (ESA) in 1992. After a year of training at the Johnson Space Center, he qualified as a mission specialist for Space Shuttle flights. Clervoy flew twice aboard Space Shuttle *Atlantis* and has logged over 483 hours in space. He served as a mission specialist on STS-66 in 1994 and as the payload commander on STS-84 in 1997.

Steven L. Smith, NASA Astronaut. Steven Smith is payload commander and EVA crewmember (designated EV1 on EVA Days 1 & 3). He was born in Phoenix, Arizona, but considers San Jose, California, to be his hometown. He received both bachelor and master of science degrees in electrical engineering and a master's degree in business administration from Stanford University. Smith served as a mission specialist aboard the Space Shuttle *Endeavour* on STS-68 in 1994. His responsibilities during the 11-day flight included Shuttle systems and Space Radar Lab 2 (the flight's primary payload). Smith flew as an EVA crew member on STS-82, the HST Second Servicing Mission, in 1997. He made two 6-hour space walks while installing new science instruments and upgraded technology. From November 1994 until March 1996, Smith was assigned to the astronaut support team at Kennedy Space Center. The team was responsible for Space Shuttle prelaunch vehicle checkout, crew ingress and strap-in, and crew egress post landing.

John M. Grunsfeld, Ph.D., NASA Astronaut. John Grunsfeld is an astronomer and an EVA crewmember (EV2 on EVA Days 1 & 3) on the SM3A mission. He was born Chicago, Illinois..2-12 Grunsfeld received a bachelor of science degree in physics from the Massachusetts Institute of Technology in 1980 and a master of science degree and a doctor of philosophy degree in physics from the University of Chicago in 1984 and 1988, respectively. Grunsfeld reported to the Johnson Space Center in 1992 for a year of training and became qualified for flight selection as a mission specialist. A veteran of two space flights, he has logged over 644 hours in space. On his first mission, STS-67 in March 1995, Grunsfeld and the crew conducted observations around the clock to study the far ultraviolet spectra of faint astronomical objects and the polarization of ultraviolet light coming from hot stars and distant galaxies. Grunsfeld flew on STS-81 in 1991 on the fifth mission to dock with Russia's Space Station Mir and the second to exchange U.S. astronauts.

C. Michael Foale, Ph.D., NASA Astronaut. Michael Foale is an EVA crewmember (EV1 on EVA Days 2 & 4) on SM3. He was born in Louth, England, but considers Cambridge, England, to be his hometown. He attended the University of Cambridge, Queens' College, receiving a bachelor of arts degree in physics, with first-class honors, in 1978. He completed his doctorate in Laboratory Astrophysics at Cambridge in 1982. NASA selected Foale as an astronaut candidate in 1987 and he completed astronaut training and evaluation in 1988. A veteran of four space flights, Foale has logged over 160 days in space including 10-1/2 hours of EVA. He was a mission specialist on STS-45 in 1992 and STS-56 in 1993, the first two ATLAS missions to address the atmosphere and its interaction with the Sun. He was a member of the first Shuttle crew (STS-63) to rendezvous with Russia's Mir Space Station in 1995. Foale spent four months aboard Mir in 1997, conducting various science experiments and helping the crew resolve and repair numerous malfunctioning systems. He arrived May 17 on Space Shuttle *Atlantis* (STS-84) and returned October 6, also on *Atlantis* (STS-86).

Claude Nicollier, ESA Astronaut. Claude Nicollier is an EVA crewmember (EV2 on EVA Days 2 & 4) on SM3A. A native of Vevey, Switzerland, he received a bachelor of science degree in physics from the University of Lausanne in 1970 and a master of science degree in astrophysics from the University of Geneva in 1975. He became a Swiss Air Force pilot in 1966, an airline pilot in 1974, and a test pilot in 1988. In July 1978 ESA selected Nicollier as a member of the first group of European astronauts. Under agreement between ESA and NASA, he joined the NASA astronaut candidates selected in 1980 for training as a mission specialist. A veteran of three space flights, Nicollier has logged more than 828 hours in space. He participated in the deployment of the European Retrieval Carrier (EURECA) science platform on STS-46 in 1992. He was the RMS operator on STS-61 in 1993, the first HST servicing and repair mission. He also served as a mission specialist on STS-75 aboard *Columbia* in 1996 – the reflight of the Tethered Satellite System and the third flight of the United States Microgravity Payload.

2.7 Servicing Mission Activities

After *Discovery* berths the Hubble Space Telescope in October 1999, the seven-person crew will begin an ambitious servicing mission. Four days of EVA tasks are scheduled. Each EVA session is scheduled for six hours.

2.7.1 Rendezvous With the Hubble Space Telescope

Discovery will rendezvous with Hubble in orbit 320 nautical miles (512 km) above the Earth. K9322-02M.2-13 Prior to approach, in concert with the Space Telescope Operations Control Center (STOCC) at GSFC, Mission Control will command HST to stow the High Gain Antennas (HGA) and close the aperture door. As *Discovery* approaches the Telescope, Commander Brown will control the thrusters to avoid contaminating HST with propulsion residue. During this approach the Shuttle crew will be in close contact with Mission Control at JSC.

As the distance between *Discovery* and HST decreases to approximately 200 ft (60 m), the STOCC ground crew will command HST to perform a final roll maneuver to position itself for grappling. The Solar Arrays (SA) will remain fully deployed parallel to the optical axis of the Telescope.

When *Discovery* and HST achieve the proper position, Mission Specialist Clervoy will operate the robotic arm to grapple the Telescope. Using a camera mounted at the berthing ring of the FSS platform in the cargo bay, he will maneuver HST to the FSS, where the Telescope will be berthed and latched.

Once the Telescope is secured, the crew will remotely engage the electrical umbilical and switch Hubble from internal power to external power from *Discovery*. Pilot Kelly also will maneuver the Shuttle so that the SAs face the Sun to recharge the Telescope's six onboard nickel-hydrogen (NiH 2) batteries.

2.7.2 Extravehicular Servicing Activities – Day by Day

Figure 2-7 shows the schedule for four planned six-hour EVA servicing periods. These time spans are planning estimates; the schedule will be modified as needed as the mission progresses.

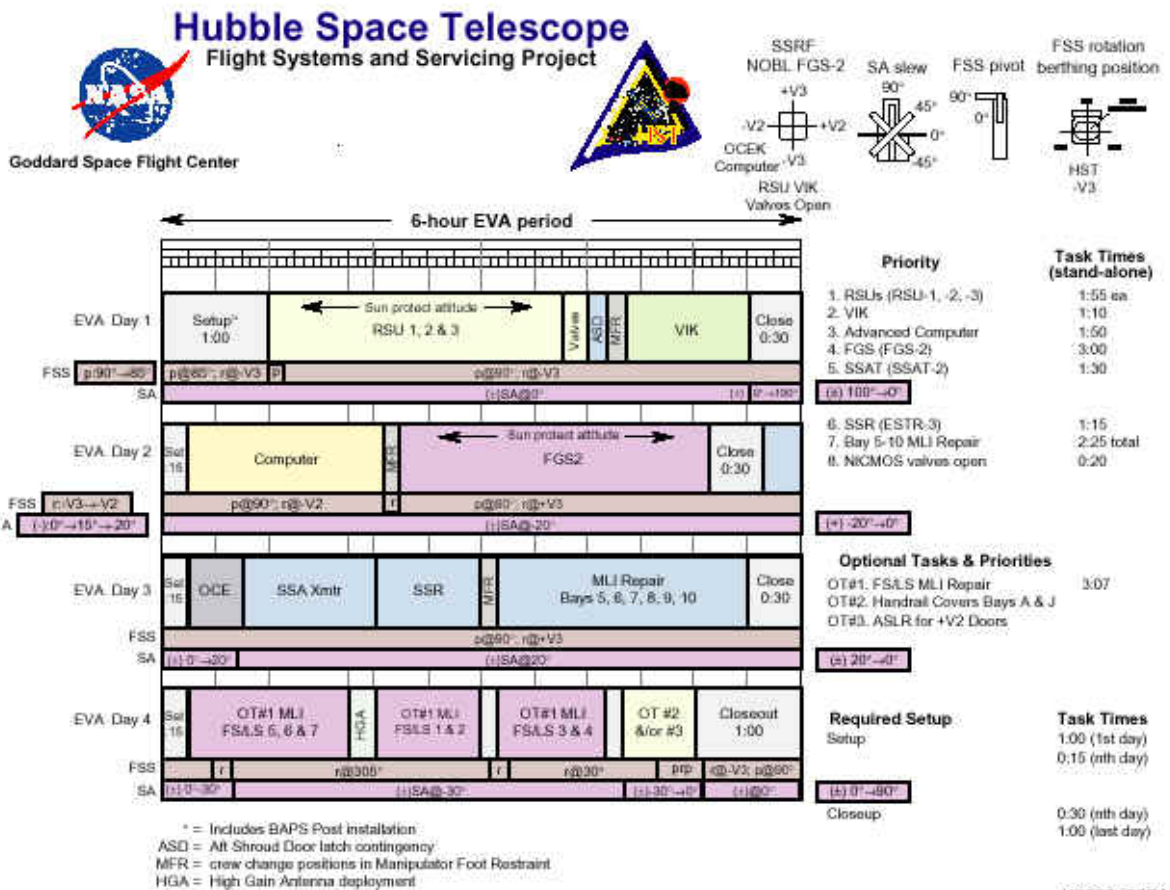

Fig. 2-7 Detailed schedule of extravehicular activities and SA and FSS positions during SM3A

During the EVAs, HST will be vertical relative to *Discovery*'s cargo bay. Four EVA mission specialists will work in two-person teams on alternate days. One team is Steve Smith and John Grunsfeld; the other is Mike Foale and Claude Nicollier.

One astronaut, designated EV1, accomplishes primarily the free-floating portions of the EVA tasks. He can operate from a PFR or while free floating. The other astronaut, EV2, works primarily from an MFR mounted on *Discovery*'s robotic arm (RMS), removing and installing the ORUs on the Hubble. EV1 assists EV2 in removal of the ORUs and installation of the replaced units in the SM3A carriers.

To reduce crew fatigue, EVA crewmembers swap places once during each EVA day; the free floater goes to the RMS MFR and vice versa. Inside *Discovery*'s aft flight deck, the off-shift EVA crewmembers and the designated RMS operator assist the EVA team by reading out procedures and operating the RMS.

At the beginning of EVA Day 1 (the fourth day of the mission), the first team of EVA astronauts suit up and pass through the *Discovery* airlock into the cargo bay. To prevent themselves from accidentally floating off, they attach safety tethers to a cable running along the cargo bay sills. EV1 accomplishes a variety of specific tasks to prepare for that day's EVA servicing activities. These include removing the MFR from its stowage location and installing it on the RMS grapple fixture, installing the Low Gain Antenna Protective Cover (LGA PC), deploying the Translation Aids (TA), and removing the Berthing and Positioning System (BAPS) Support Post from its stowage location and installing it on the FSS with the assistance of EV2.

Meanwhile, EV2 brings out of the airlock the Crew Aids and Tools (CATs) that will be attached to the handrails of the RMS. He installs the CATs handrail to the RMS and the color television camera (CTVC) on the MFR. The IVA RMS operator then moves EV2 to the BAPS Support Post (BSP) installation worksite to install the BSP forward end on the BAPS.

EVA Day 1: Change out three RSUs. Remove caps and open the NICMOS "Coolant In" and "Coolant Out" valves. Install VIK on HST batteries.

During EVA Day 1, Smith and Grunsfeld are scheduled to replace three new RSUs in the Telescope. They will also remove caps from the NICMOS "Coolant In" and "Coolant Out" valves. Any ice contained within those valves will sublime in the vacuum of space and facilitate installation of a replacement cooler for NICMOS on SM3B. Additionally, the astronauts will install VIKs on the six batteries aboard HST.

Once in the payload bay, the astronauts begin the initial setup, which includes installation of the LGA protective cover, TA deployments, and installation and deployment of the BSP.

The BSP is required to dampen the vibration that the servicing activities will induce into the deployed SAs. Prior to the BSP installation on EVA Day 1, the IVA team commands the HST to an 85-degree pivot angle. The two center push-in-pull out (PIP) pins are installed each day and removed each night in the event that the Shuttle must make an emergency return to Earth. Steve Smith (EV1) removes the BSP from its stowage position in the cradle of the FSS and hands the forward end to John Grunsfeld (EV2) who installs his end to the BAPS ring with a PIP pin. Smith then installs the aft end of the BSP to the FSS cradle with a PIP pin. Finally the BSP is commanded to its 90-degree limit and the two center PIP pins are installed.

After the BSP is installed and other initial setup tasks are completed, the crew starts the specific tasks for the RSU changeouts. First Smith, who is free floating, retrieves the STS PFR and Articulating Socket and temporarily stows them at the aft ORUC. Smith and Grunsfeld (in the MFR), move to the COPE to retrieve the replacement RSU-2. To accomplish the removal, they open three COPE T-handle lid latches and the COPE lid, then release the transport module T-handle latch and open it. They remove the replacement RSU-2 and stow it in the ORU transfer bag. Next they close the transport module and the COPE lid and engage two T-handle latches.

The astronauts then translate to the aft shroud. They inspect the area for excessive particulates or debris and when satisfied that the area is clear, Smith and Grunsfeld open the HST -V3 aft shroud doors by retracting two Fixed Head Star Tracker (FHST) seals and disengaging four door latches.

Smith then installs the PFR and articulating socket in the HST aft shroud and ingresses. Smith and Grunsfeld remove the old RSU-2 by demating two wing tab connectors and disengaging three 7/16-in. hex-head captive spring-loaded fasteners. Smith and Grunsfeld remove the RSU-2 replacement from the ORU transfer bag. They remove the two connector caps and install the replacement RSU-2 in HST, engaging three fasteners and mating the two connectors (see Fig. 2-8). Finally, they replace the old RSU-2 in the ORU transfer bag.

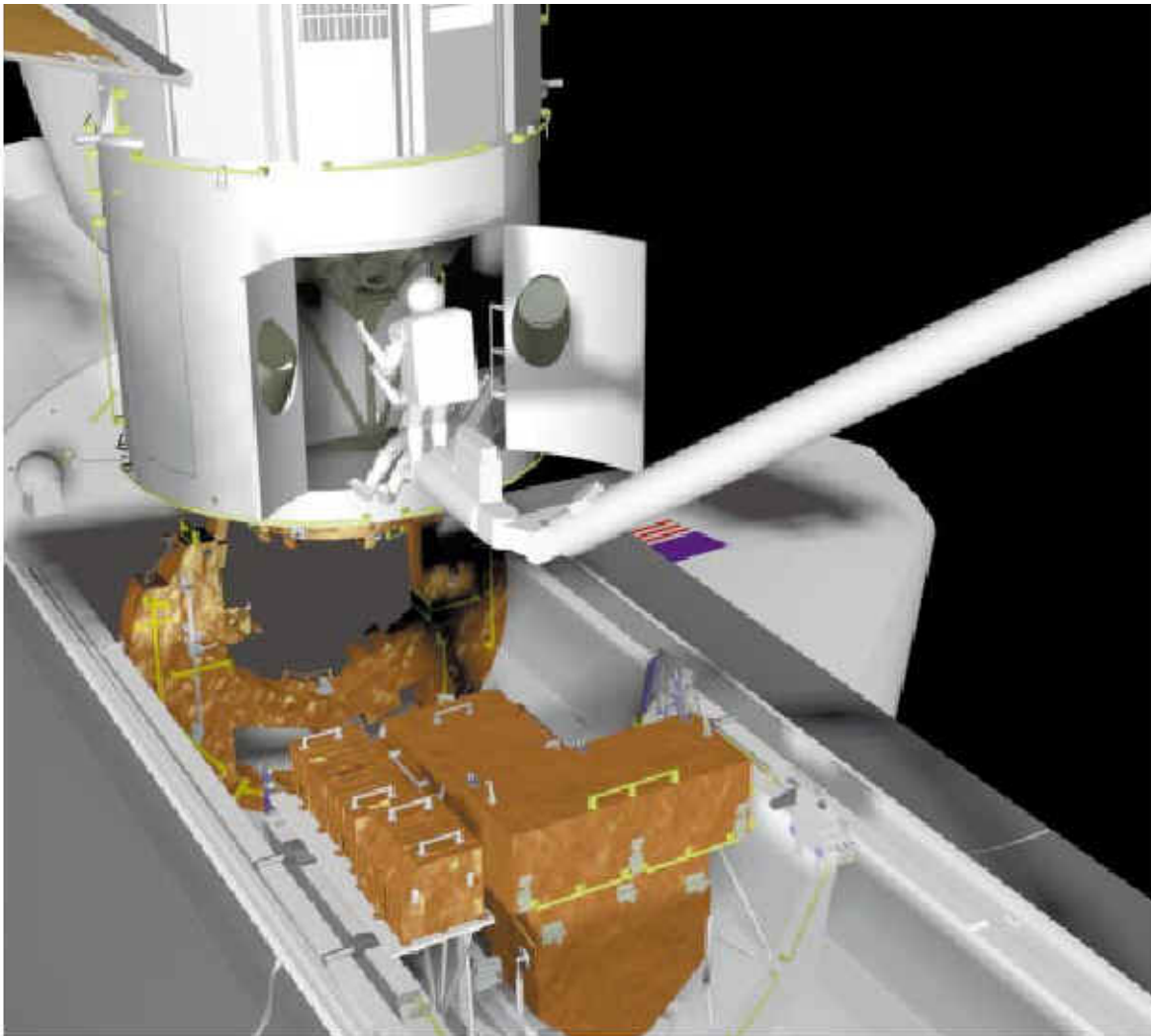

Fig. 2-8 Change-out of Rate Sensor Unit

Smith steps out of the PFR, reconfigures it for the RSU-3 position, and gets back into the PFR. Meanwhile, Grunsfeld maneuvers to the COPE and opens the lid, stowing the old RSU-2 and retrieving the RSU-3 replacement. He stows it in the ORU transfer bag, then temporarily closes the COPE lid (two latches) and maneuvers back to the aft shroud.

Smith and Grunsfeld remove the old RSU-3 by demating two wing tab connectors and disengaging three 7/16-in. hex captive spring-loaded fasteners. They then remove the replacement RSU-3 from the ORU transfer bag and install it, first removing the two connector caps, then seating it in HST. They engage three fasteners, mate the two connectors and place the old RSU-3 in the ORU transfer bag.

Smith exits the PFR and reinstalls it in the aft shroud door closing position. Grunsfeld performs a video closeout on the two newly installed RSUs. He then maneuvers to the COPE and stows RSU-3. He retrieves the replacement RSU-1 and stows it in the ORU transfer bag. He temporarily closes the COPE lid (one latch) and maneuvers back to the aft shroud.

Grunsfeld, on the MFR at the end of the RMS, removes the old RSU-1 by demating two wing tab connectors and disengaging three 7/16-in. hex captive spring-loaded fasteners. They install the replacement RSU-1 by removing the two connector caps, removing the replacement from the ORU transfer bag, seating it in HST K9322-02M.2-16 and engaging three fasteners, and mating two connectors. After the old RSU-1 is stowed in the ORU transfer bag, Grunsfeld performs the replacement RSU-1 video close-out.

While positioned at the Aft Shroud, Smith and Grunsfeld then perform the NICMOS valve reconfiguration. They remove two "Coolant In" and "Coolant Out" bayonet caps and open the "Coolant In" and "Coolant Out" valves. Grunsfeld performs the NICMOS valve reconfiguration video close-out.

Grunsfeld partially closes the -V3 Aft Shroud doors as Smith ingresses the PFR. With Smith's assistance, Grunsfeld closes the left and right doors, engages the four door latches, checks the door seals, and extends the two FHST light seals. Smith egresses the PFR/Articulating Socket, removing it from HST and restowing it in cargo bay. Grunsfeld maneuvers to the COPE and stows the old RSU-

1 in the transport module, closes the transport module lid, then fully closes the COPE lid, engaging all three latches.

Smith and Grunsfeld now prepare to install VIKs on the HST batteries. Smith takes Grunsfeld's place on the MFR and Grunsfeld becomes the free floater after the MFR swap.

Grunsfeld translates to airlock, retrieves the VIK Caddy, translates to Bay 3, and transfers the VIK Caddy to Smith. Smith (in the MFR) opens the Bay 3 door by disengaging six J-hooks. Grunsfeld retrieves the handrail cover caddy, inspects the handrails around Bays 2 and 3, and installs the handrail covers if needed. Smith demates three Bay 3 battery connectors (one at a time) and installs a VIK in-line with each battery connector (see Fig. 2-9). Smith performs the Bay 3 VIK video close-out, closes the door, and engages the six door J-hooks.

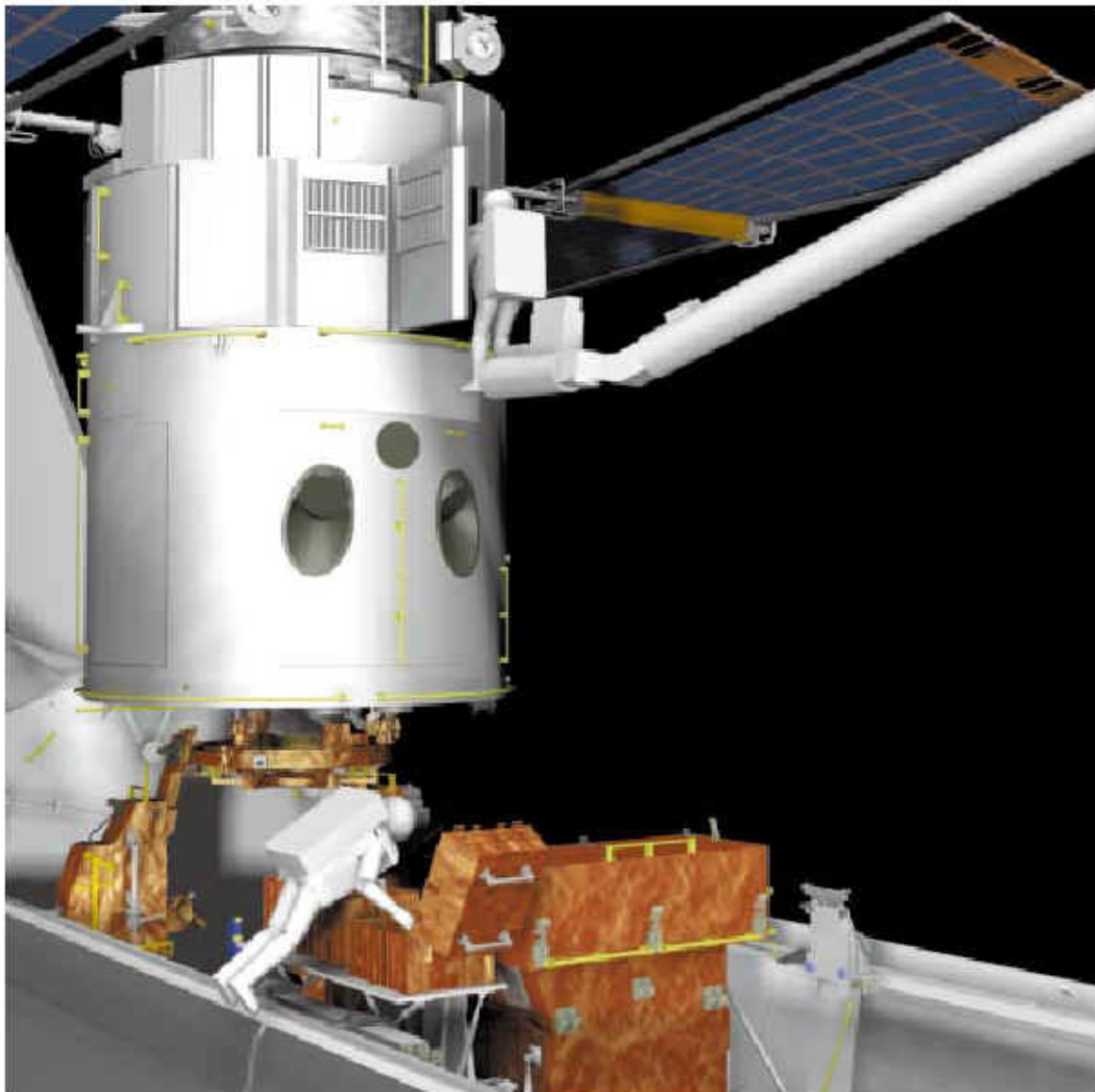

Fig. 2-9 Voltage/Temperature Improvement Kit installation

Smith then opens Bay 2 door by disengaging six J-hooks. He demates three Bay 2 battery connectors (one at a time) and installs a VIK in-line with each battery connector. He performs the Bay 2 VIK video close-out, closes the door, engages the six door J-hooks, and stows the VIK Caddy on the MFR.

For the daily close-out, Grunsfeld removes the center pins on the BSP, inspects the FSS main umbilical, and retracts the TAs while Smith prepares the CATs installed on the MFR handrail for return into the airlock. Additionally, Smith releases the MFR safety tether from the grapple fixture for contingency Earth return and releases the lower CTVC cable. After the completion of EVA Day 1, both astronauts return to the airlock with the Day 1 CATs installed on the MFR handrail.

EVA Day 2: Replace DF-224 computer with Advanced Computer and install Bay 1 NOBL. Change out FGS-2.

During EVA Day 2, EVA astronauts Nicollier (EV1) and Foale (EV2) are scheduled to replace HST's DF-224 computer with a faster, more powerful unit called the Advanced Computer. They will also change out a degraded FGS in position number 2 (see Fig. 2-10).

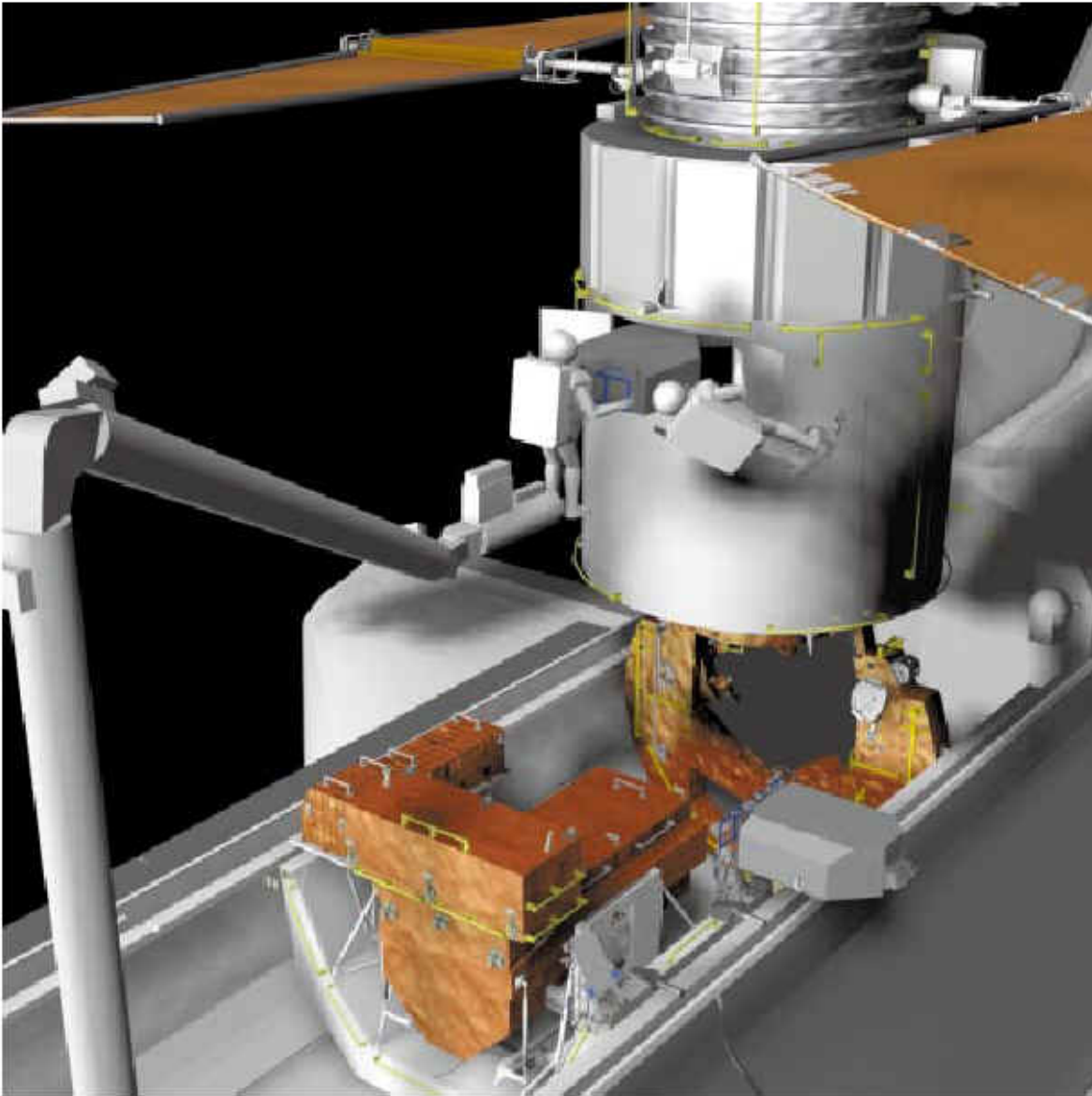

K9329_210

Fig. 2-10 Fine Guidance Sensor change-out

Fewer daily setup tasks are required for EVA Day 2 than for EVA Day 1. Foale exits the airlock with the EVA Day 2 required CATs installed on the MFR handrail. Nicollier reconnects the safety strap on the MFR and connects the CTVC cable to the RMS end effector. Foale then installs the MFR handrail and the CTVC on the RMS. Nicollier deploys the TAs and installs the BSP center PIP pins.

The astronauts' first servicing task for the day is to change out the DF-224 computer with the new Advanced Computer. Foale (in the MFR) maneuvers to the COPE Converter Transport Module and retrieves the Connector Converter Caddy. Foale then maneuvers to the Bay 1 worksite and installs handrail covers on the handrails adjacent to the Bay 1 door if he deems them necessary.

Meanwhile, Nicollier (free floating) translates to the LOPE and opens the LOPE lid by disengaging four J-hook bolts. He removes the Y-harness and mates one end of it to the Advanced Computer. Nicollier also prepares the Advanced Computer for Foale to remove from the LOPE, releasing five of its six J-hooks and temporarily closing the LOPE lid and engaging a single J-hook.

Foale opens the Bay 1 door by disengaging six J-hooks and sets the integral door stay. Nicollier translates back to Bay 1 to assist Foale with the computer swap. Foale removes the DF-224 computer by demating its nine electrical connectors and disengaging six J-hooks. He transfers it to Nicollier positioned at the MFR stanchion. Foale then installs the seven connector converters on the HST harnesses.

Nicollier transfers the DF-224 computer to Foale for the maneuver to the LOPE worksite. Foale transfers the DF-224 computer back to Nicollier and opens the LOPE lid by disengaging one J-hook. Foale removes the Advanced Computer from the LOPE by disengaging one J-hook, then maneuvers back to Bay 1.

Meanwhile, Nicollier installs the DF-224 computer in the LOPE, engaging six J-hooks, then closes the LOPE lid and engages four J-bolts. Nicollier translates back to the Bay 1 worksite to assist Foale. Foale installs the Advanced Computer in Bay 1 by engaging six J-hooks, mating two remaining Y-harness connectors, and mating seven harnesses. He then performs the Advanced Computer video close-out, releases the door stay, and closes the Bay 1 door, engaging six J-hooks.

After the computer change-out, Nicollier and Foale open the NPE, retrieving the Bay 1 NOBL and NOBL plug stringer from the NPE and closing it. They install the Bay 1 NOBL on the Bay 1 door by installing four NOBL vent hole plugs and connecting the NOBL ground cap to the door J-bolt.

As the astronauts prepare to undertake the FGS-2 change-out, Nicollier replaces Foale on the MFR and Foale becomes the free floater.

Nicollier and Foale retrieve a PFR/PFR Extender and set it up on the HST in Foot Restraint 11. Nicollier retrieves the outboard FGS handhold from the ORUC forward fixture and installs handrail covers at FGS-2 worksite as needed. Foale deploys the aft fixture.

The astronauts open and secure the FGS bay doors and demate the FGS connectors and ground strap. Nicollier installs four guide studs on the FGS, then installs the FGS handhold and loosens the A latch. The FGS is now ready to be removed.

With Foale in the PFR and Nicollier holding the FGS handhold, the team removes the FGS as Foale gives clearance instructions. To ensure successful installation of the replacement FGS, the team may practice reinsertion of the old FGS back into the HST guiderails without latching the latches or mating the connectors for mass handling evaluation.

After this practice insertion, Nicollier removes the FGS and stows it on the aft fixture. Foale then conducts a bay inspection. Next, Foale translates to the ORUC FSIPE, opens the lid, latches the lid in the open position, and demates and secures the ground strap. In parallel, Nicollier retrieves the other FGS handhold from the ORUC forward fixture and positions himself for its installation on the replacement FGS in the FSIPE.

After installing the handhold on the replacement FGS, Nicollier loosens the A latch. Then, with instructions and assistance from Foale, Nicollier removes the replacement FGS from the FSIPE and translates with it to the HST. Foale closes the FSIPE lid and engages one lid latch. He then ingresses the PFR mounted on the HST and prepares to remove the FGS mirror cover. Nicollier presents the FGS to Foale so that the FGS mirror cover can be removed. Foale tethers to the cover, releases the slide lock lever, and operates the handle to remove the mirror cover. When the mirror cover is removed, IVArepositions Nicollier on the MFR so the FGS can be installed.

Nicollier inserts the FGS with assistance from Foale (see Fig. 2-10). Nicollier tightens the A latch, removes the FGS handhold, and stows it temporarily on the MFR, then installs the ground strap and electrical connectors. After the electrical connectors are mated, IVA informs Mission Control to perform an aliveness test. Nicollier takes the close-out photographs (video), closes and latches the doors, and checks the door seals. He then retrieves the HST PFR and stows it for later reinstallation in the cargo bay. Foale stows the mirror cover on the ORUC.

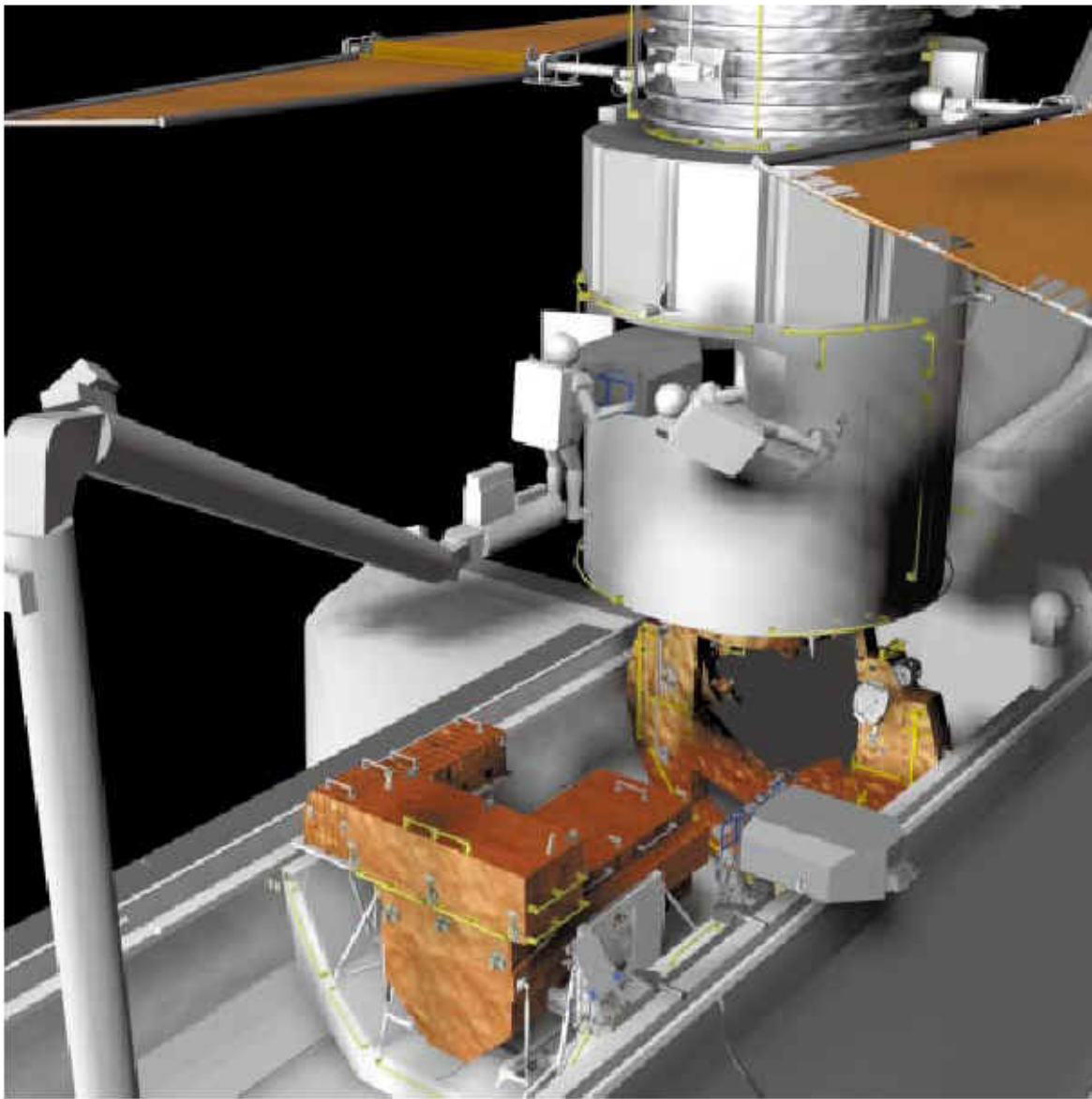

Fig. 2-10 Fine Guidance Sensor change-out

Nicollier retrieves the FGS from the aft fixture. Foale stows the aft fixture, translates to the FSIPE, and opens the lid. Nicollier translates to the FSIPE with the FGS. Foale assists Nicollier during the FGS insertion into FSIPE. After full insertion, Nicollier tightens the A latch while Foale mates the ground strap. Foale releases the FSIPE on-orbit latches and closes and secures the lid. Nicollier stows the replacement FGS handhold in the forward fixture. Foale retrieves the PFR that was used for the FGS change-out and reinstalls it on the Shuttle bay adaptive payload carrier.

For the EVA Day 2 daily close-out, Foale removes the center pins on the BSP, inspects the FSS main umbilical mechanism, and retracts the TAs while Nicollier prepares the CATs installed on the MFR handrail for return to the airlock. Foale releases the MFR safety tether from the RMS in the event of contingency Earth return. Both astronauts return to the airlock with the MFR handrail and its installed CATs.

EVA Day 3: Mate additional OCE-EK connectors for the new FGS-2. Change out SSAT. Replace E/STR #3 with SSR #3. Repair MLI.

On EVA Day 3, EVA astronauts Smith and Grunsfeld are scheduled to mate additional OCE-EK connectors to allow for the on-orbit alignment optimization of the replacement FGS adjustable, articulated, fold flat #3 mirror. They will replace an S-band single access transmitter (SSAT) that failed in 1998. An identical backup transmitter has functioned perfectly and HST's observing program has not been affected. The astronauts also will install an SSR in place of an E/STR. Finally, they will undertake MLI repairs over the doors on Bays 5 through 10.

The daily setup for EVA Day 3 is identical to EVA Day 2. Smith still exits the airlock with the required CATs and CTVC installed on the MFR handrail and transfers them to Grunsfeld. He reconnects the safety strap on the MFR/RMS and connects the CTVC to the RMS end-effector. Grunsfeld installs the MFR handrail and the CTVC on the RMS. Smith deploys the TA and installs the BSP center PIP pins.

The first task of the day is the mating of the OCE-EK connectors. Grunsfeld on the RMS translates to the Optical Telescope Assembly (OTA) Bay C door and opens the door via the three J-hooks. He then demates the P11 connector from the OCE, and mates the OCE-EK J/P11 A with the OCE J11 and HST P11 connectors. The close-out photographs are taken and the Bay C door is secured with its three J-hooks.

Grunsfeld on the MFR then opens the Bay 5 door by disengaging six J-hooks, then secures the door in the open position. He prepares the old SSAT-2 for removal by demating two circular connectors and three coaxial connectors. He installs a fastener retention block, removes eight non-captive bolts/washers, and removes the old SSAT-2. Grunsfeld transfers the SSAT-2 to Smith, who is free floating.

Smith brings the old SSAT-2 to the COPE, opens it, and retrieves the replacement SSAT. He stows the old SSAT in the COPE, closes it, and translates back to Bay 5. Grunsfeld receives the replacement SSAT-2 from Smith, installs it on the Bay 5 door by engaging seven bolts, removing the two connector caps, mating two circular connectors, and mating three coaxial connectors (see Fig. 2-11). Grunsfeld then performs the video close-out. Because the SSR installation is the next task, the Bay 5 door is left open.

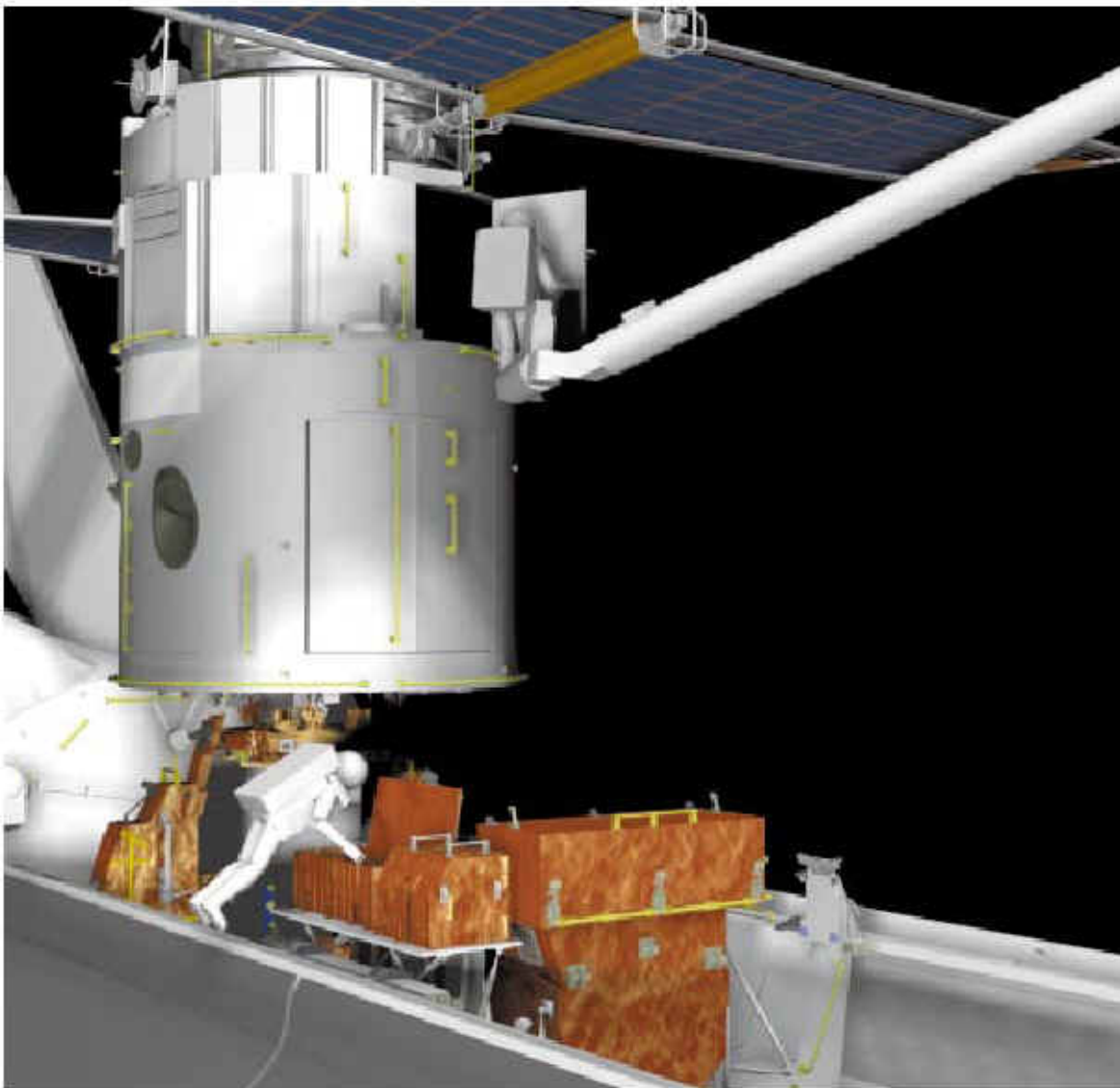

K9322_211

Fig. 2-11 S-Band Single Access Transmitter change-out

The next change-out task is replacement of the E/STR-3 with a newer technology SSR-3. Grunsfeld demates the T-harness installed during SM2 and two other E/STR-3 connectors, being careful not to allow the powered-on P1 connector to touch structure ground. He secures the P1 connector behind the cable harness along the side wall, demates the four keyhole fasteners, and removes the E/STR.

Smith and Grunsfeld translate to the COPE with the E/STR-3. Smith releases the COPE lid latches and opens the lid. Smith and Grunsfeld remove SSR-3 from the COPE transport module and install the E/STR-3 into the COPE transport module. Grunsfeld translates back to the Bay 5 worksite. Smith stows the T-harness in the COPE lid, retrieves the J-harness, then closes and latches the lid. He then translates with the J-harness to Bay 5 to assist with the SSR installation.

In parallel to Smith's closure of the COPE, Grunsfeld installs the SSR into the #3 position (see Fig. 2-12). SSR-3 is mounted via four keyhole bolts. The SSR3 connector caps are removed and the connectors mated, then the .2-22 K9322-02M J-harness is mated to the J-4 connectors on SSR-3 and SSR-1. The J-harness provides increased capability for the SSR and HST. Grunsfeld takes the close-out video. With the assistance of Smith, Grunsfeld closes the door and secures it with the six J-hooks.

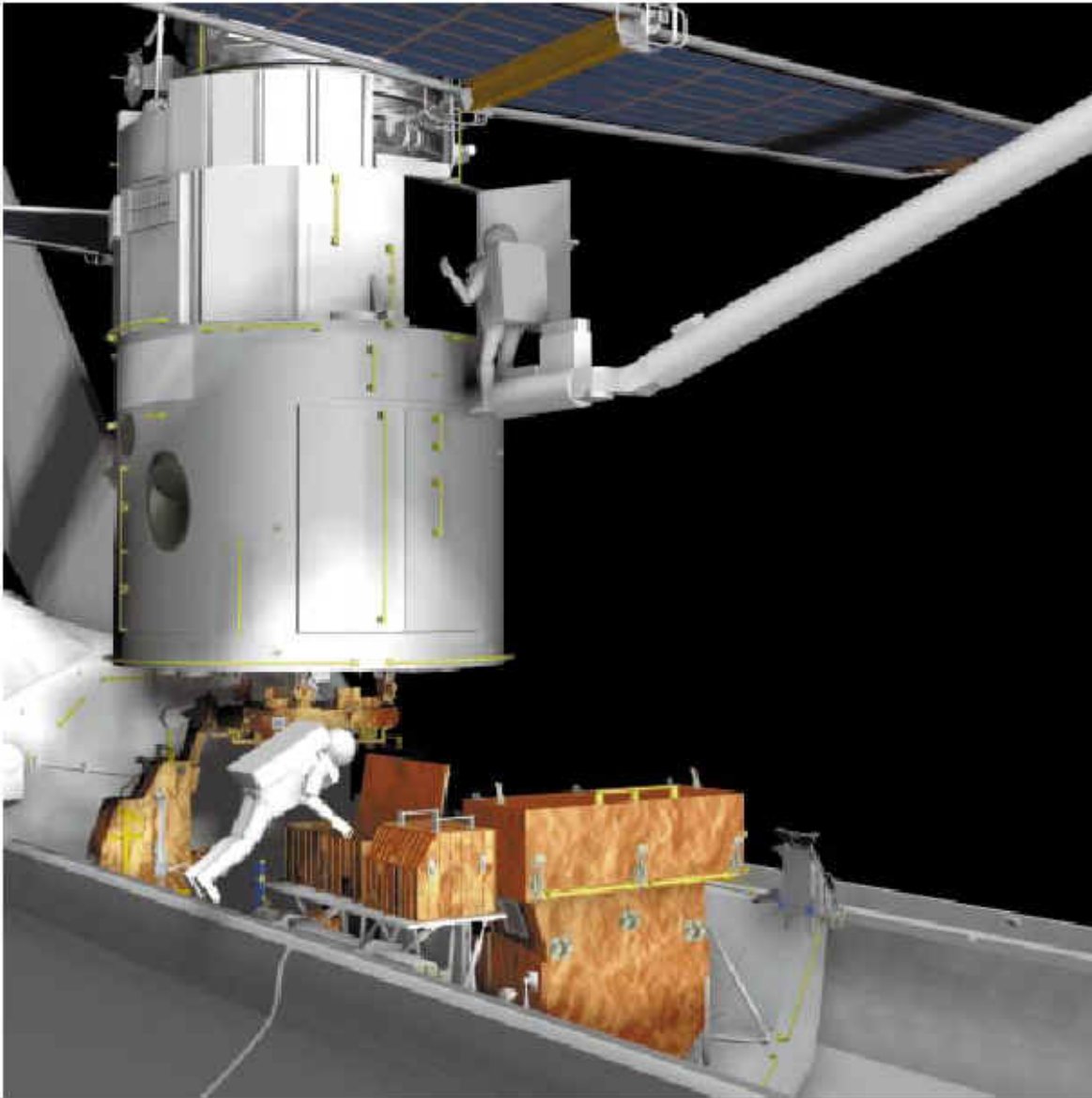

K9322_212

Fig. 2-12 Installation of Solid State recorder

The crewmembers now swap roles: Smith moves to the MFR and Grunsfeld becomes free floating. Grunsfeld retrieves the MLI recovery bags from ORUC ATM. Smith opens the NPE and retrieves the NOBLs for Bays 5 and 6 and a single NOBL plug stringer. He temporarily closes the NPE by securing one latch.

Grunsfeld assists Smith throughout the NOBL installation process. Smith installs the Bay 6 NOBL to the door stop and secures the handle attachment to the door handle. He removes the two Bay 7 tie wraps and stows them in the trash bag, then removes the two Bay 8 patches and stows them in an MLI recovery bag. The patches were installed during SM2.

Smith removes the original Bay 5 door MLI and stows it in an MLI recovery bag. He installs the Bay 5 NOBL and secures it with the four

NOBL plugs, then connects the NOBL ground cap to a J-bolt (see Fig. 2-13).

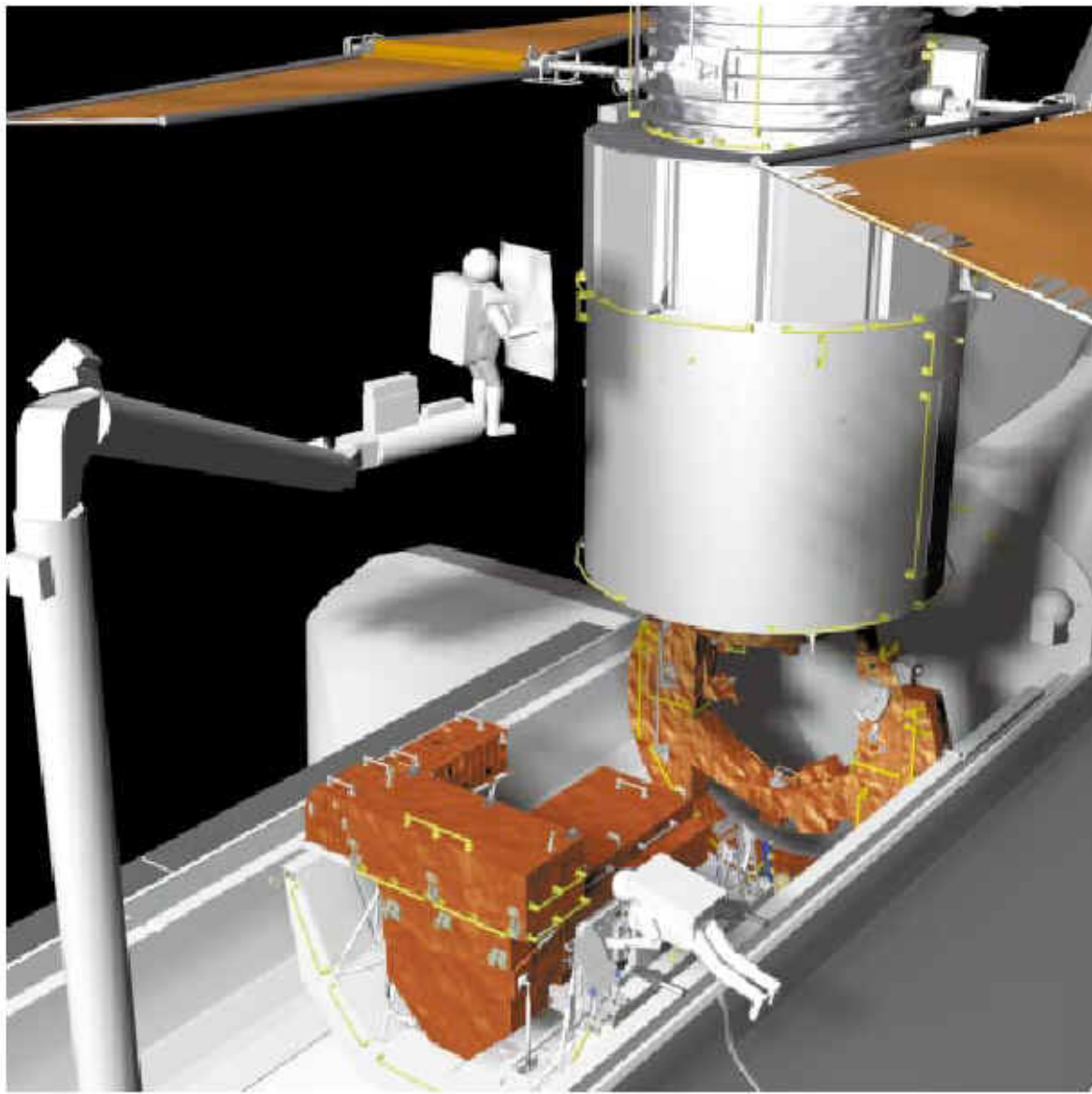

K9322_213

Fig. 2-13 New outer blanket layer installation

Smith retrieves the Bay 7 and Bay 8 NOBL and two vent plug stringers from the NPE and temporarily closes the NPE, securing a single latch. He installs the Bay 7 NOBL, securing it with the four NOBL plugs, then connects the NOBL ground cap to a J-bolt.

Smith installs the Bay 8 NOBL and secures it with the NOBL plugs, then connects the NOBL ground cap to a J-bolt. He removes the two MLI patch kits installed on Bay 10 during SM2 and stows them in an MLI recovery bag, then removes the two original Bay 10 door MLI pieces and stows them in an MLI recovery bag.

Smith retrieves the Bay 9 and Bay 10 NOBL and NOBL plugs from the NPE and closes the NPE, securing all three latches. He installs the Bay 9 NOBL to the door stop and secures the handle attachment to the door handle. Smith then installs the Bay 10 NOBL and secures it with the four NOBL plugs, then connects the NOBL ground cap to a J-bolt.

For the Day 3 EVA close-out, Grunsfeld removes the center pins on the BSP, inspects the FSS main umbilical mechanism, and retracts the TAs while Smith prepares the CATs installed on the MFR handrail for return into the airlock. Smith releases the MFR safety tether from the RMS in the event of contingency Earth return. After completion of the EVA Day 3 close-outs, both astronauts return to the airlock with the MFR handrail and its installed CATs.

EVA Day 4: EVA Day 4 consists of a series of scheduled and optional tasks: Install SSRFs on the forward shell/light shield. Install handrail covers on the Bays A and J handrails. Install Aft Shroud Latch Repair (ASRL) Kits on the +V2 aft shroud doors.

EVA crewmembers Foale and Nicollier are scheduled to install new insulation material on the outer surfaces of the Telescope where MLI has become degraded. Optional tasks are to install handrail covers where the paint covering has debonded and install repair kits to functionally replace the degraded aft shroud door latches.

EVA Day 4 has a daily setup similar to that of the prior EVA days. Nicollier starts the day in the MFR. Foale exits the airlock with the required CATs installed on the MFR handrail and the CTVC and transfers them to Nicollier. Nicollier reconnects the safety strap on the MFR/RMS and connects the CTVC cable to the RMS end-effector. Nicollier then installs the MFR handrail and the CTVC to the RMS. Foale deploys the TAs and installs the BSP center PIP pins.

Foale opens the ORUC ASIPE by disengaging the five lid latches. Nicollier opens the lid. Foale retrieves the five SSRF rib clamps and Nicollier retrieves SSRFs 5, 6, and 7. Nicollier closes the ASIPE lid temporarily by engaging a single lid latch.

Foale and Nicollier install the five SSRF rib clamps on the HST station 358 rib. Working as a team, Foale and Nicollier install SSRFs 5, 6, and 7.

Nicollier opens the ASIPE and retrieves SSRFs 1, 2, 3, and 4. He then fully closes the ASIPE, engaging the five lid latches. Nicollier and Foale translate to HST and installs SSRFs 1 and 2.

When that task is complete, the IV crew rotates the FSS to the HST 30-degree position. Nicollier and Foale install SSRFs 3 and 4. Both then install two ASLR Kits on the two degraded +V2 door latches if needed. The handrail covers also can be installed, if needed, at this time.

For the final daily close-out, Foale stows the TAs, removes and stows the LGAPC, inspects the FSS main umbilical mechanism, and inspects the P105/P106 connector covers. Nicollier installs the CATs on the MFR handrail for return to the cabin and demates and stows the MFR from the RMS. When the tasks are complete, both crewmembers enter the airlock with the CATs-laden MFR handrail.

EVA Contingency Day.

An unscheduled EVA day has been allocated for enhancing payload mission success and for any payload requirements on the HST redeployment day.

Redeploying the Telescope.

The day following EVADay 4 will be devoted to any unscheduled EVA tasks and redeployment of the HST into Earth orbit (see Fig. 2-14).



K9322_214

Fig. 2-14 Redeploying the Space Telescope

The SAs are slewed to the Sun to generate electrical power for the Telescope and to charge the batteries, and HGAs are commanded to their deployed position. When the battery charging is complete, the RMS operator guides the robotic arm to engage HST's grapple fixture. The ground crew commands Hubble to switch to internal power. This accomplished, crew members command Discovery's electrical umbilical to demate from Hubble and open the berthing latches on the FSS. If any Telescope appendages fail to deploy properly, two mission specialists can perform EVA tasks on the redeployment day, manually overriding any faulty mechanisms.

2.8 Future Servicing Plans

As the Hubble Space Telescope enters the 21st century, other enhancements are planned. A third-generation instrument, the Advanced Camera for Surveys (ACS), will greatly enhance HST's imaging capabilities. Shuttle astronauts plan to install the camera during SM3B. ACS is truly an advanced camera, with predicted performance improvements one to two orders of magnitude over current Hubble science instruments. Its unique characteristics and dramatically improved efficiencies will exploit the full potential of the Telescope to serve the needs of the science community.

Periodic upgrades and servicing will ensure that Hubble continues to yield remarkable advances in our knowledge of the universe.

HUBBLE SPACE TELESCOPE SCIENCE AND DISCOVERIES

A golden era of space exploration and discovery began April 24, 1990, with the launch and deployment of NASA's Hubble Space Telescope (HST). During nearly 10 years of operation, Hubble's rapid-fire rate of unprecedented discoveries has invigorated astronomy. Not since the invention of the telescope nearly 400 years ago has our vision of the universe been so revolutionized over such a short stretch of time.

As the 12.5-ton Earth-orbiting observatory looks into space unburdened by atmospheric distortion, new details about planets, stars, and galaxies come into crystal clear view. The Telescope has produced a vast amount of information and a steady stream of images that have astounded the world's astronomical and scientific communities. It has helped confirm some astronomical theories, challenged others, and often come up with complete surprises for which theories do not yet even exist.

Hubble was designed to provide three basic capabilities:

- High angular resolution – the ability to image fine detail
- Ultraviolet performance – the ability to produce ultraviolet images and spectra
- High sensitivity – the ability to detect very faint objects.

Each year NASA receives over a thousand new observing proposals from astronomers around the world. Observing cycles are routinely over-subscribed by a factor of three or greater.

The Telescope is extremely popular because it allows scientists to get their clearest view ever of the cosmos and to obtain information on the temperature, composition, and motion of celestial objects by analyzing the radiation emitted or absorbed by the objects. Results of HST observations are being presented regularly in scientific papers at meetings of the American Astronomical Society and other major scientific conferences.

Although Hubble's dramatic findings to date are too numerous to be described fully in this Media Reference Guide, the following paragraphs highlight some of the significant astronomical discoveries and observations in three basic categories:

- Planets
- Formation and evolution of stars and planets
- Galaxies and cosmology.

For further detailed information, visit the Space Telescope Science Institute website at: <http://opposite.stsci.edu>.

3.1 Planets

Since 1990 Hubble has kept an "eye" on our solar system planets: a comet slamming into Jupiter, clouds on Uranus, monster storms on Neptune, auroras on Jupiter and Saturn, and unusual weather on Mars.

Mars.

The Telescope captured images of an enormous cyclonic storm system raking the northern polar regions of Mars on April 27, 1999 (see Fig. 3-1). Nearly four times the size of Texas, the storm consists of water ice clouds like those found in storm systems on Earth rather than the dust typically found on Mars. Although similar to so-called "spiral" storms observed more than 20 years ago by NASA's Viking Orbiter spacecraft, this Martian storm is nearly three times the size of the largest previously detected Martian storm system.

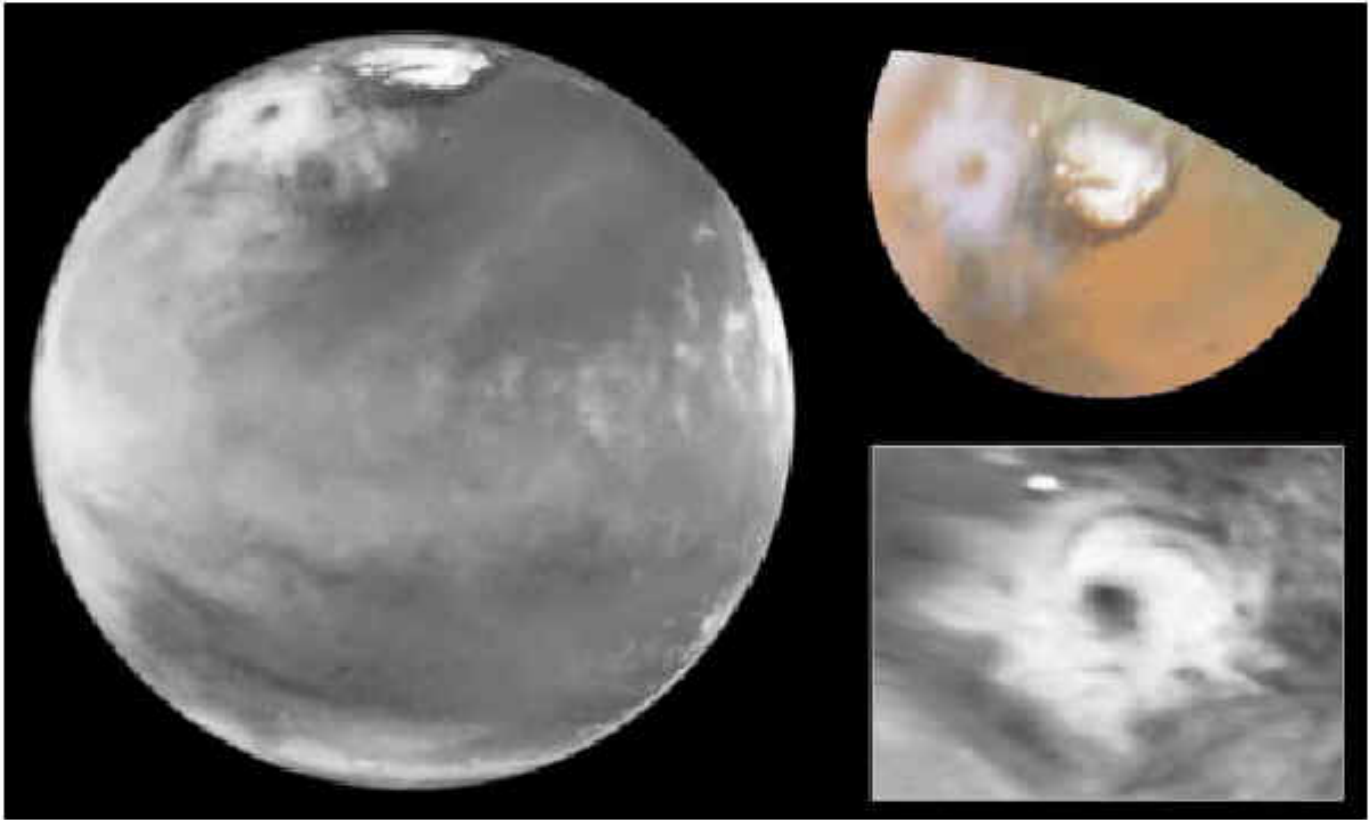

K9322-301

Fig. 3-1 On April 27, 1999, Hubble took pictures of a Martian storm more than 1000 miles (1600 km) across. Left: an image of the polar storm as seen in blue light (410 nm). Upper right: a polar view of the north polar region, showing the location of the storm relative to the classical bright and dark features in this area. Lower right: an enhanced view of the storm processed to bring out additional detail in its spiral cloud structures.

The Telescope monitored the Red Planet's weather in the spring and summer of 1997, providing detailed reports to help plan the landing of NASA's Mars Pathfinder and the arrival of Mars Global Surveyor. Pictures taken about a week before the landing of the Pathfinder spacecraft show a dust storm churning through the deep canyons of Valles Marineris, just 600 miles (1,000 kilometers) south of the landing site. Remarkable changes in the behavior of dust and water ice clouds on the planet were recorded from July 9 to 11, indicating that weather changes on Mars are very rapid – possibly chaotic.

Hubble took pictures of the entire planet of Mars during its closest approach to Earth in eight years: 54 million miles (87 million kilometers). Using the HST images, astronomers made a full-color global map of Mars (see Fig. 3.2). Latitudes below about 60 degrees south were not viewed because the planet's north pole was tilted towards Earth during that time.

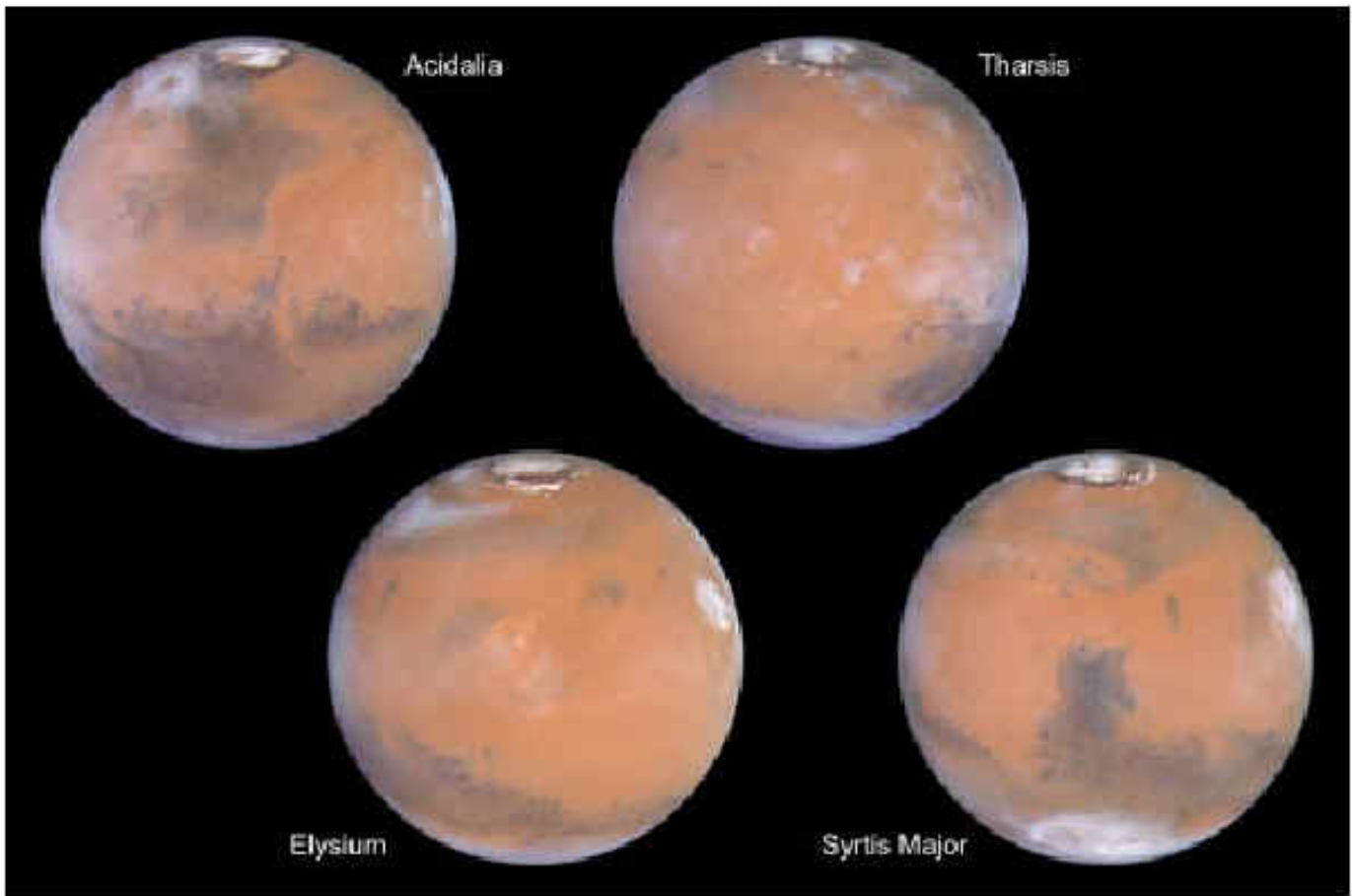

K9322-302

Fig. 3-2 The HST WFPC2 captured these images between April 27 and May 6, 1999, when Mars was 54 million miles (87 million kilometers) from Earth. From this distance the telescope could see Martian features as small as 12 miles (19 kilometers) wide.

Saturn and Jupiter.

Astronomers used Hubble's ultraviolet-light camera, the Space Telescope Imaging Spectrograph (STIS), to probe auroras – curtains of light that seem to dance above the north and south poles of Saturn and Jupiter.

Saturn's auroras rise more than 1,000 miles above the cloud tops (see Fig. 3-3). Like those on Earth, these auroral displays are caused by an energetic wind from the Sun that sweeps over the planet. But unlike Earth, Saturn's auroras have been seen only in ultraviolet light.

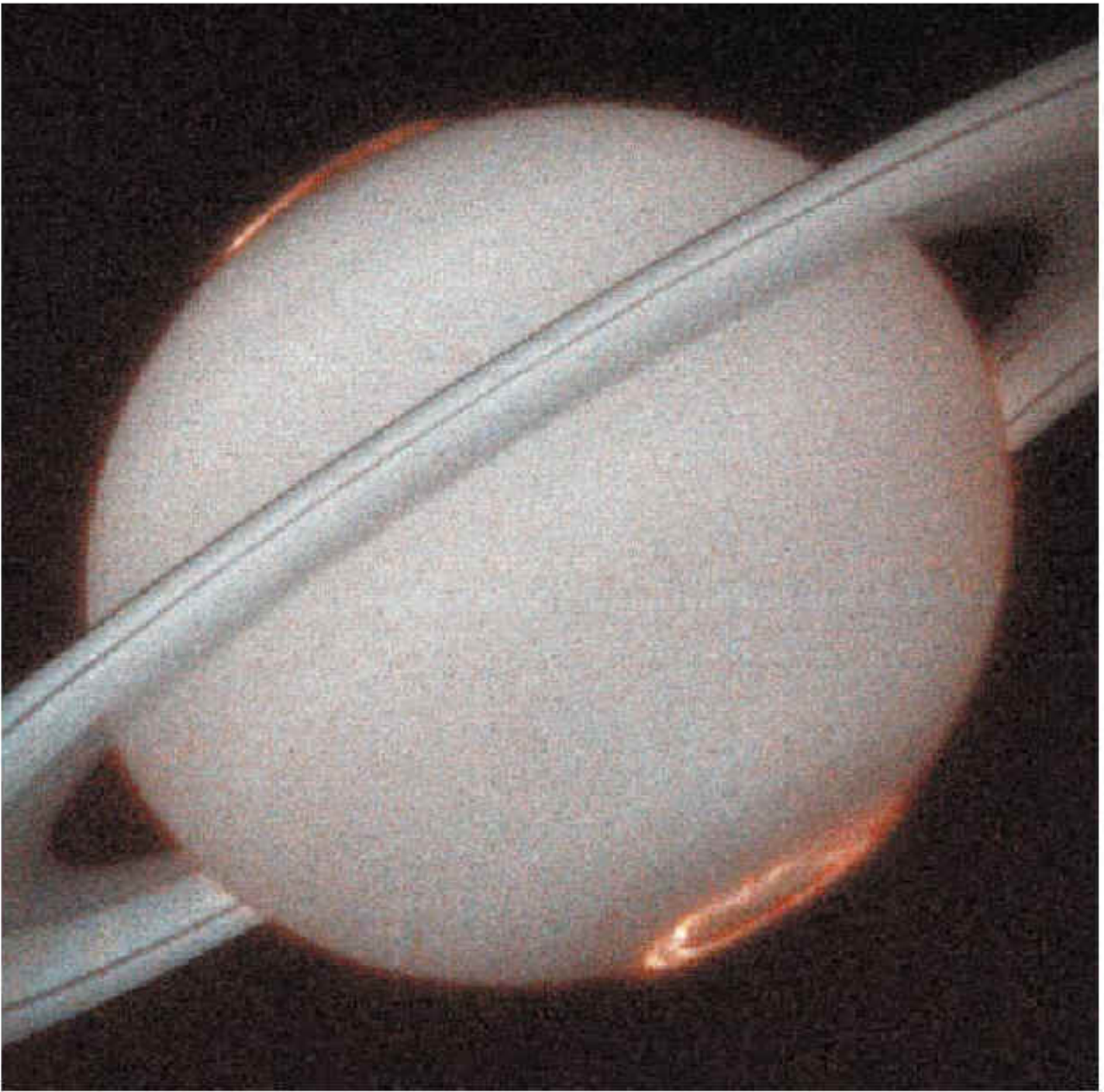

K9922-303

Fig. 3-3 This is the first image of Saturn's ultraviolet aurora taken by the STIS in October 1997, when Saturn was 810 million miles (1.3 billion kilometers) from Earth.

The auroras are primarily shaped and powered by a continual tug-of-war between Saturn's magnetic field and the flow of charged particles from the Sun.

The Telescope has also taken many images of Jupiter's aurora in ultraviolet light. Jovian auroral storms develop when electrically charged particles trapped in the magnetic field surrounding the planet spiral inward at high energies toward the north and south magnetic poles. As these particles strike the upper atmosphere, they excite atoms and molecules there, causing them to glow.

Hubble's Near Infrared Camera and Multi-Object Spectrometer (NICMOS) has provided a multicolor view of

Saturn, giving detailed information on the clouds and hazes in the planet's atmosphere (see Fig. 3-4).



Fig. 3-4 Saturn viewed in the infrared shows atmospheric clouds and hazes.

K9322-304

The blue colors in the NICMOS image of Saturn indicate a clear atmosphere down to a main cloud layer. Most of the northern hemisphere visible above the rings is relatively clear. The dark region around the south pole corresponds to the region of auroral activity and displays different reflective properties. The green and yellow colors define a haze above the main cloud layer; the haze is thin where the colors are green and thick where they are yellow. Due to Saturn's east-west winds, these layers are aligned along latitude lines. The red and orange colors indicate clouds reaching high into the atmosphere. Red clouds are higher than orange clouds. The densest regions of two storms near Saturn's equator appear white.

The Telescope captured an invasion of Jupiter in 1994 when 21 fragments of the comet Shoemaker-Levy 9 slammed into the giant planet. As each comet fragment crashed into Jupiter, mushroom-shaped plumes were expelled from the planet. The largest fragment impacts created Earth-sized "bull's-eye" patterns on Jupiter. Hubble's record of the comet's bombardment, combined with results from other space-borne and Earth-based telescopes, sheds new light on Jupiter's atmospheric winds and its immense magnetic field.

Uranus.

Astronomers used Hubble images, taken from 1994 to 1998, to create a time-lapse movie that shows, for the first time, seasonal changes on Uranus. Once considered a bland-looking planet, Uranus is now revealed as a dynamic world with rapidly changing bright clouds – some circling the planet at more than 300 miles per hour – and a fragile ring system that wobbles like an unbalanced wagon wheel. The clouds probably are made of crystals of methane, which condense as warmer bubbles of gas well up from deep in the planet's atmosphere. The movie clearly shows for the first time the wobble in the ring system, comprising billions of tiny pebbles. The wobble may be caused by Uranus's shape, which is like a slightly flattened globe, and the gravitational tug from its many moons.

Uranus is tilted completely over on its side, giving rise to 20-year-long seasons and unusual weather. For nearly a quarter of the Uranian year, the Sun shines directly over each pole, leaving the other half of the planet in a long, dark, frigid winter. Now the northern hemisphere of Uranus is coming out of the grip of its two-decade winter.

Neptune.

The unusual weather patterns of Neptune also are the subject of a time-lapse rotation movie using HST images. The movie shows that the planet has some of the wildest, weirdest weather in the solar system. The Telescope captured the most insightful images to date of a planet whose blustery weather – monster storms and equatorial winds of 900 miles per hour – is still a mystery to scientists.

Pluto.

Even the outermost planet in our solar system hasn't escaped Hubble's scrutiny. The Telescope unveiled the never-before-seen surface of Pluto, orbiting at the dim outer reaches of the solar system nearly three billion miles (five billion kilometers) from the Sun. Pluto is only two-thirds the size of the Earth's moon but is 12,000 times farther away.

The Faint Object Camera (FOC) imaged nearly the entire surface of Pluto as it rotated through its 6.4-day period in late June and early July 1994. The images, made in blue light, show that Pluto is an unusually complex object, with large-scale contrast.

3.2 Formation and Evolution of Stars and Planets

Planets form from leftover star-making material, the pancake-shaped disks of dust and gas swirling around nascent stars. Hubble has provided evidence that these disks are common around developing stars. The Telescope also has expanded astronomers' knowledge about the life cycle of stars. It has peeked behind the dusty veil of star birth regions to chronicle the genesis of stars and captured the colorful shrouds around dying stars.

The giant galactic nebula NGC 3603 (see Fig. 3-5) contains a community of stars in various stages of life. Dark clouds in the upper right are so-called Bok globules, dense clouds of dust and gas that harbor embryonic stars. Giant pillars of gas (below and right of the blue cluster of stars), composed of cold molecular hydrogen, serve as an incubator for new stars. Ultraviolet light from the nearby star cluster is sculpting the pillars, which are reminiscent of the famous pillars the Hubble photographed in the M16 Eagle Nebula.

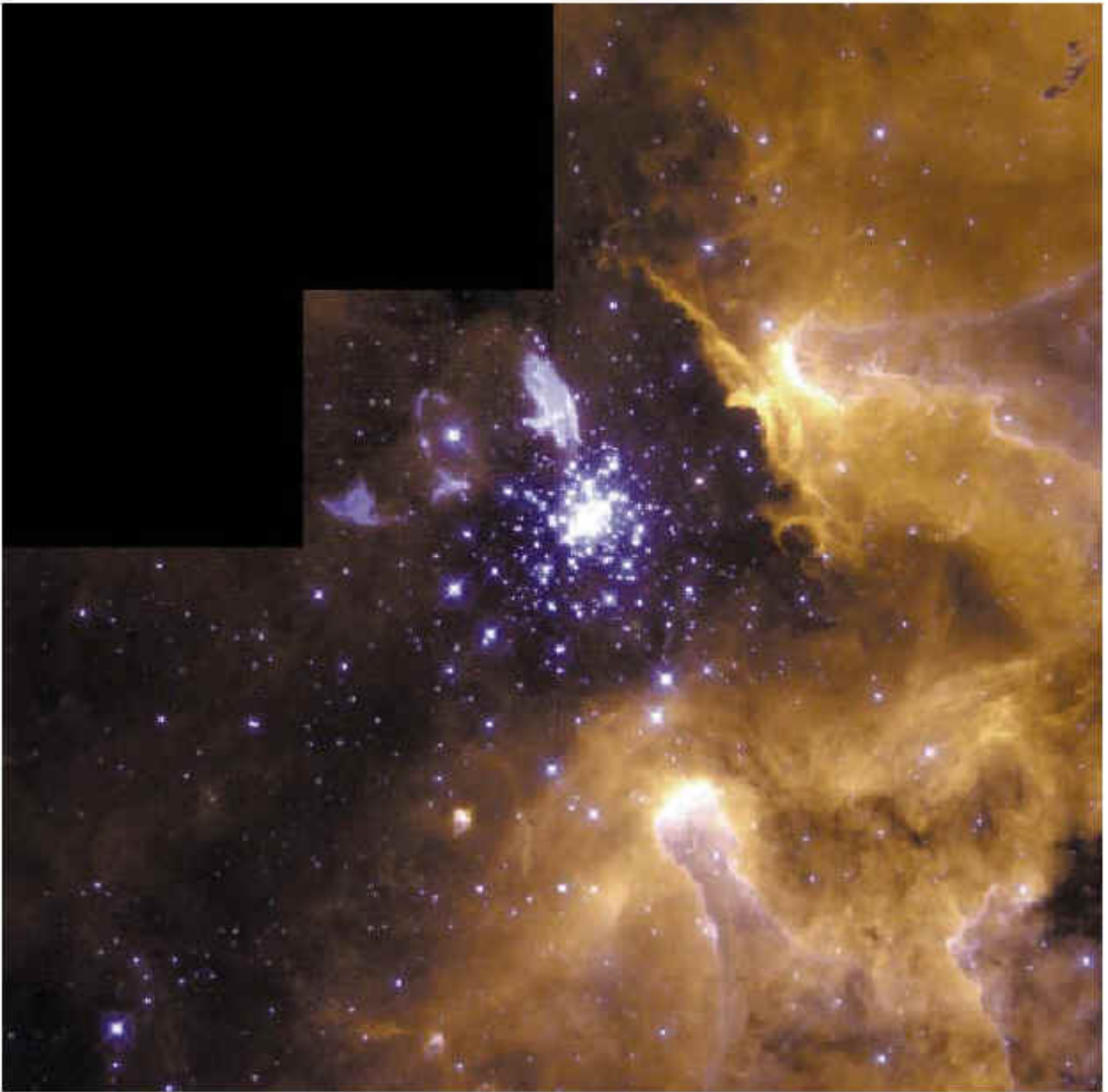

Fig. 3-5 The crisp resolution of the Telescope reveals various stages of the life cycle of stars in this single view of the giant galactic nebula NGC 3603.

Below the cluster are two compact, tadpole-shaped protoplanetary disks. Near the center of the image is a starburst cluster dominated by young, hot Wolf-Rayet stars and early O-type stars. A torrent of ionizing radiation and fast stellar winds from these massive stars has blown a large cavity around the cluster. To the upper left of center is the aging blue supergiant Sher 25. The star has a unique ring of glowing gas that is a galactic twin to the famous ring around the exploding star, supernova 1987A.

Are there other planetary systems like our own? If so, how are they created? Astronomers are on the hunt to find out. They are studying debris disks, composed of dust and gas, whirling around developing stars. This dust and gas could eventually clump together to form planets. Hubble has imaged such disks around several stars ranging in age

from 1 million to 10 million years. The Telescope's arsenal of cameras has recorded the disks in light from ultraviolet to near infrared. By chronicling the disks at different stages of a star's early life, astronomers are adding information to the planet-making recipe.

Hubble's sharp vision has analyzed disks around a group of nearby young stars in the constellation Taurus. Images taken in the near-infrared as well as visible light reveal how infalling material forms first into a thin disk around the young stars. Then a portion of the disk material is shot back into the interstellar medium in the form of opposing jets that emerge perpendicularly from the center of the disk. The accretion disks are huge, averaging more than ten times the diameter of our solar system.

The Wide Field and Planetary Camera 2 (WFPC2) spotted the first example of an edge-on disk in a young double-star system. The images offer further evidence that planet formation should be possible in binary star systems. Theory holds that gravitational forces between two stars in a binary system tend to tear apart fragile planet-forming disks, but the Hubble images reveal evidence of dust clumping together in the disks – a first step on the long road to planet formation.

Looking at a disk around a slightly older star, astronomers using STIS found evidence of more clumping of material. This two- to four-million-year-old star, called AB Aurigae, is in the constellation Auriga. The clumps are much farther away from the star than is Pluto, the outermost solar system planet, from our Sun.

Turning its gaze to a fully developed star, HR 4796A, about 10 million years old, NICMOS captured images of a wide dust ring (6.5 billion miles). The rings around the star resemble those of Saturn, but on a grander scale. Gaps between the rings could be the result of unseen bodies sweeping out lanes. The star is 220 light-years away in the constellation Centaurus.

Hubble also has provided images of what may be the most luminous known star, called the Pistol Star, which is big enough to fill the diameter of Earth's orbit. This celestial mammoth releases up to 10 million times the power of the Sun, unleashing as much energy in three seconds as our Sun does in one year. The NICMOS image also reveals a bright nebula created by massive stellar eruptions. The nebula is so big (four light-years across) that it would span nearly the distance from the Sun to Alpha Centauri, the nearest star to Earth's solar system.

Astronomers estimate that when the Pistol Star was formed one to three million years ago, it may have weighed up to 200 times the mass of the Sun before shedding much of its bulk in violent eruptions. The star is approximately 25,000 light-years from Earth near the center of the Milky Way.

A star like our Sun spends its embryonic years accumulating mass until it reaches maturity. When it nears the end of its life, it sheds some of its mass as it contracts to a white dwarf. As material ejected from the star is driven outward into space, radiation from the star causes it to glow. The illuminated stellar remains surrounding a dying star are called a planetary nebula. A nebula will shine for about 10,000 years.

Hubble has provided a gallery of these nebulae, which come in many shapes and glow in a kaleidoscope of colors. The Ring Nebula (M57) is a stunning example of a dying central star floating in a blue haze of hot gas (see Fig. 3-6). The colorful nebula surrounding the star appears ring-shaped, but only because of the viewing angle. Many astronomers believe that the nebula is actually a cylinder and the Hubble picture supports this view.

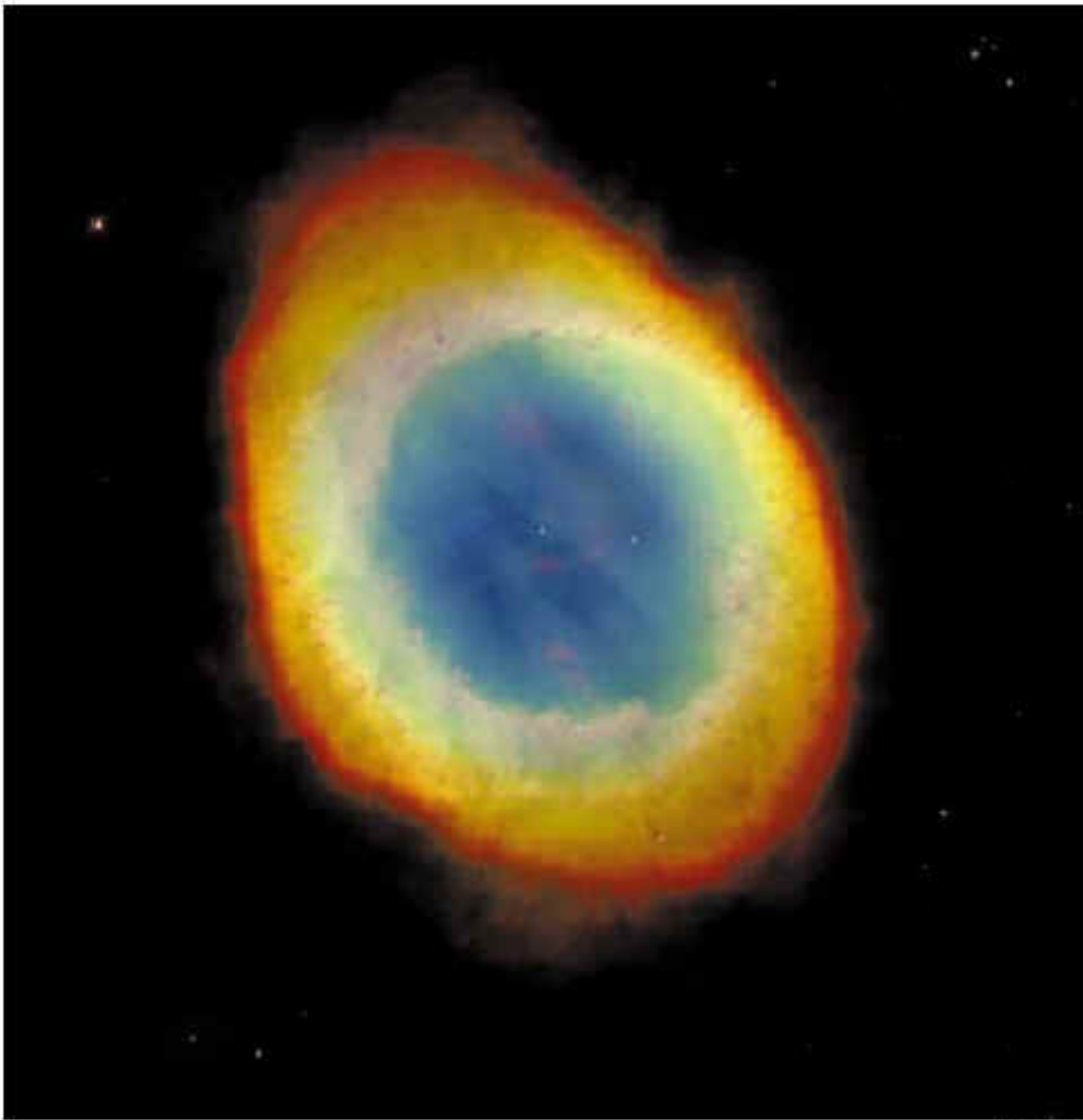

K9322-306

Fig. 3-6 In this October 1998 image of the Ring Nebula (M57), Hubble looks down a barrel of gas cast off by a dying star thousands of years ago.

The Telescope's image of the Ring Nebula shows numerous small, dark clouds of dust that have formed in the gas flowing out from the star. They are silhouetted against more distant, bright gas. These finger-like clouds appear only in the outer portions of the Ring Nebula; none are seen in the central region. This suggests that they are not distributed in a uniform sphere but are instead located only on the walls of the barrel, which is a light-year in diameter. The nebula is 2,000 light-years from Earth in the constellation Lyra.

Another striking planetary nebula is M2-9, called a "butterfly" or bipolar planetary nebula because of its shape (see Fig. 3-7). Another more revealing name might be the "Twin Jet Nebula." A companion star orbiting perilously close to its dying mate may have caused the unusual shape. Astronomers suspect the gravity of one star pulls weakly bound gas from the surface of the other and flings it into a thin, dense disk surrounding both stars. The high-speed wind of gas from one of the stars slams into the disk, which serves as a nozzle. Deflected in a perpendicular direction, the wind forms a pair of jets speeding at 200 miles per second. The nebula is 2,100 light-years away in the constellation Ophiuchus.



K9322-307

Fig. 3-7 Hubble sees supersonic exhaust from nebula M2-9, a striking example of a “butterfly” or bipolar planetary nebula.

Unlike lighter-weight stars that quietly end their lives by forming planetary nebulae, massive stars die in mammoth explosions. HST has been monitoring one such explosion, super-nova 1987A – 167,000 light-years away in the Large Magellanic Cloud. Scientists first viewed the star’s self-destruction on February 23, 1987, in a naked-eye observation. In July 1997, STIS captured the first images of material ejected by the exploding star ramming into an inner ring around the dying object (see Fig. 3-8).

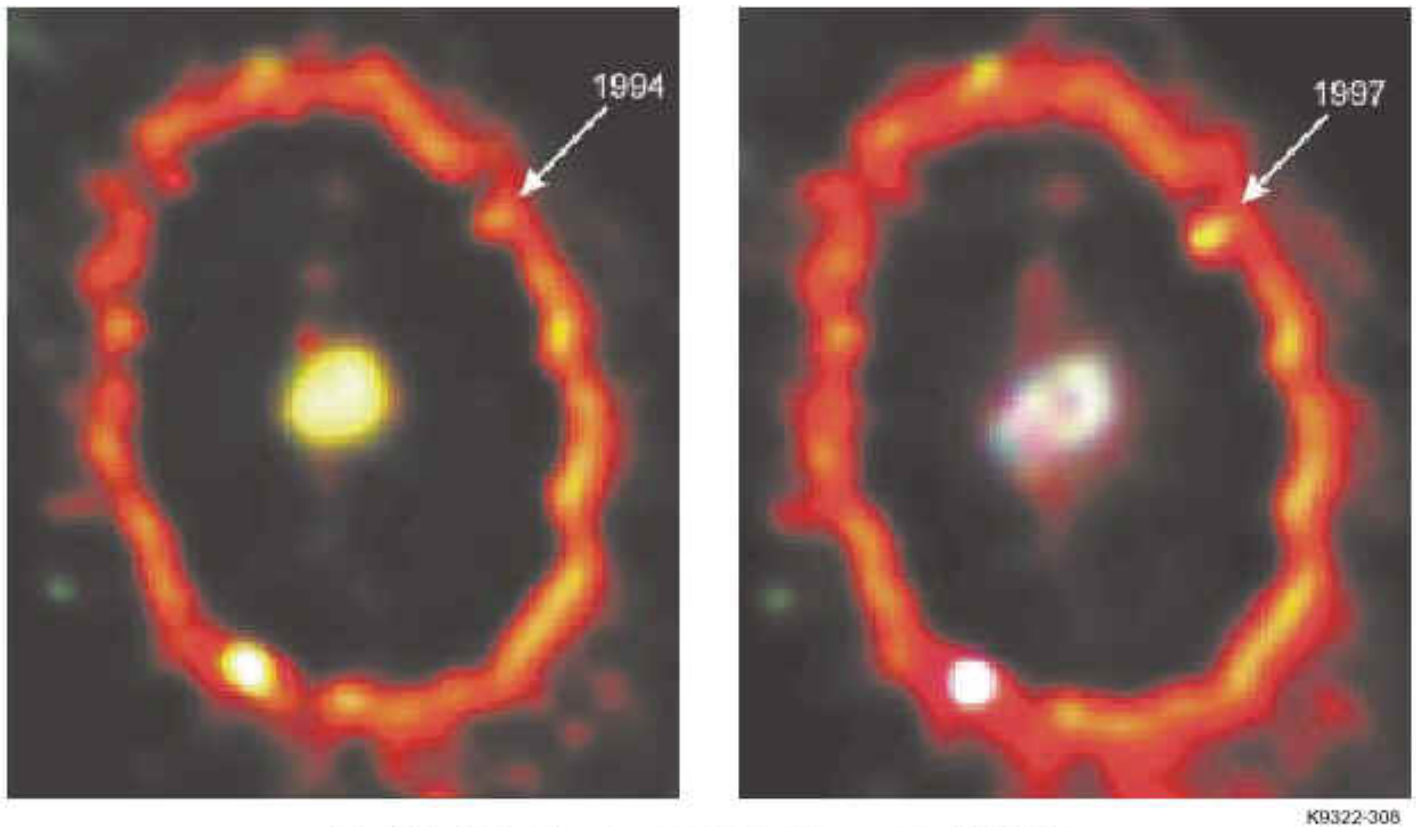

Fig. 3-8 A bright knot appears in the Supernova 1987A Ring.

Shocked by the 40-million-miles-per-hour sledge-hammer blow, a 100-billion-mile-wide knot of gas in a piece of the ring has already begun to "light up" as its temperature surges from a few thousand to a million degrees Fahrenheit. By analyzing the glowing ring, astronomers may find clues to many of the supernova's unanswered mysteries: What was the progenitor star? Was it a single star or a binary system? What was the process that created a ring that formed 20,000 years before the star exploded?

3.3 Galaxies and Cosmology

Galaxies are the largest assemblages of stars in the universe. In a galaxy, billions of stars are bound together by the mutual pull of gravity. The Sun resides in the Milky Way Galaxy.

The study of galaxies falls into the realm of cosmology, the science of the evolution of the universe on the largest scale. Edwin P. Hubble discovered the expansion of the universe by measuring the redshifts of distant galaxies. He demonstrated that the galaxies are rushing away from us, with their velocities increasing proportionally to their distances. The constant of proportionality is known as the Hubble constant. The reciprocal of the Hubble constant is an index to the age of the universe, or the time since the Big Bang.

Measuring the Hubble constant was a major goal for the Hubble Space Telescope before it was launched in 1990. In May 1999, the Telescope key project team announced that it had completed its efforts to measure precise distances to far-flung galaxies, an ingredient needed to determine the age, size, and fate of the universe. The team measured the Hubble constant at 70 km/sec/Mpc, with an uncertainty of 10 percent. This means that a galaxy appears to be moving 160,000 miles per hour faster for every 3.3 million light-years away from Earth.

Using the Telescope, the team observed 18 galaxies, some as far away as 65 million light-years. The team was looking for Cepheid variable stars, a special class of pulsating star used for accurate distance measurements.

Almost 800 Cepheids were discovered. But the team could utilize only Cepheids in nearby and intermediate-distance galaxies. To calculate distances to galaxies farther away, the team used so-called "secondary" distance measurements, such as a special class of exploding star called a Type Ia supernova. Combining the Hubble constant measurement with estimates for the density of the cosmos, the team has determined that the universe is approximately 12 billion years old and that it contains insufficient mass to halt the expansion of space. This was, perhaps, the most important astronomical discovery of the decade.

In December 1995 the Telescope provided humankind's deepest, most detailed visible-light view of the heavens called the Hubble Deep Field. In 1998 Hubble's penetrating vision was turned toward the southern skies. The Telescope peered down a narrow, 11-billion-light-year-long corridor loaded with thousands of never-before-seen galaxies. The observation, called the Hubble Deep Field South (HDF-S), doubles the number of far-flung galaxies available for deciphering the history of the universe. In each "deep field" view, astronomers counted about 3,000 galaxies. Both views also show that galaxies were smaller in the past and have evolved to the giant spirals and ellipticals of today.

The southern "far-look" complements the original Hubble Deep Field, for which Hubble was aimed at a small patch of sky near the Big Dipper. The southern region is in the constellation Tucana, near the south celestial pole. The 10-day HDF-S observation took place in October 1998. At first glance HDF-S appears to validate the common assumption that the universe should look largely the same in any direction (see Fig. 3-9).

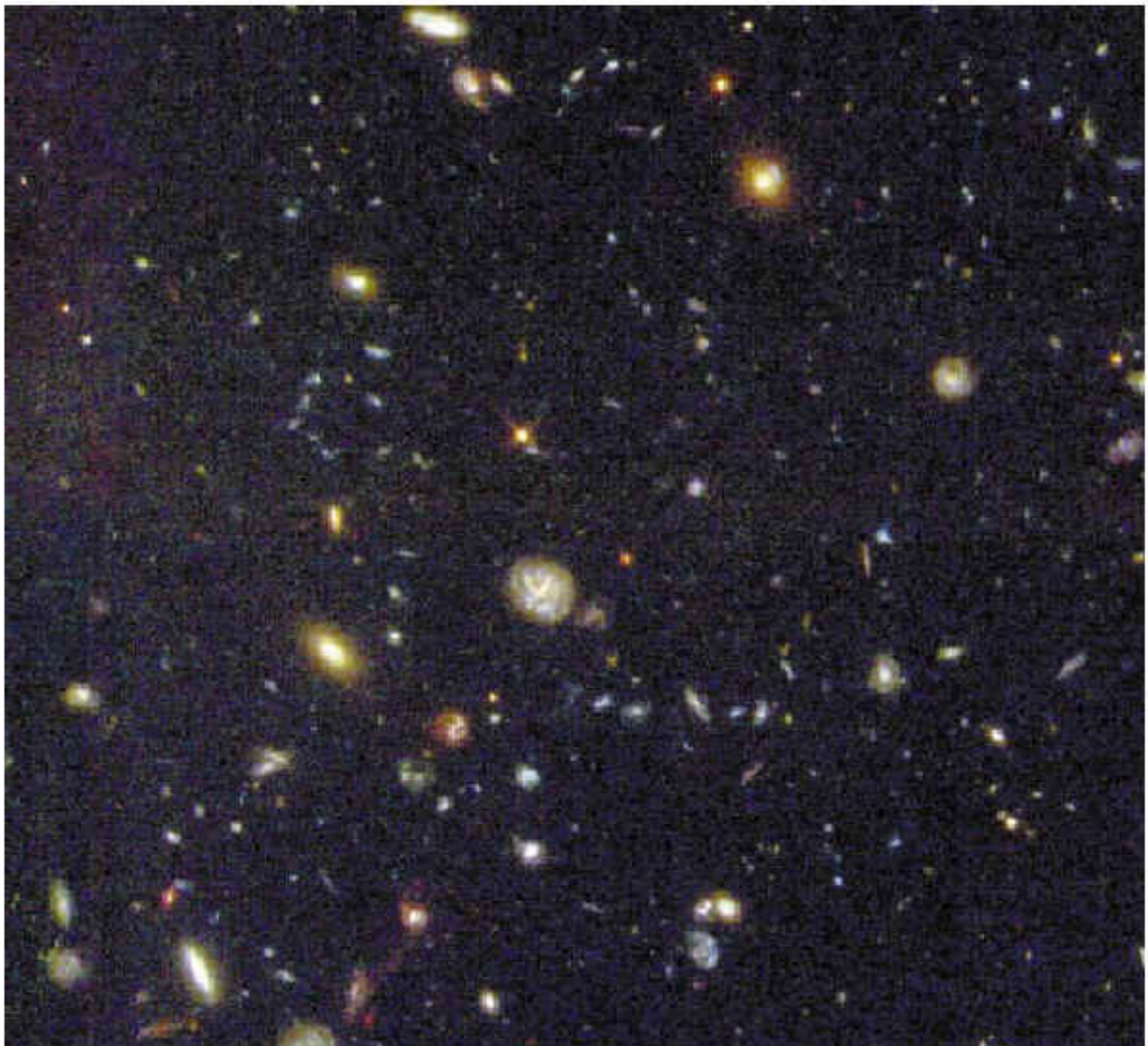



K9322-309

Fig. 3-9 In an observation called the Hubble Deep Field South (HDF-S), the Telescope peered down an 11-billion-light-year-long corridor loaded with thousands of never-before seen galaxies.

The two deep fields give astronomers two "core samples" of the universe to use for better understanding the history of the cosmos. All of Hubble's cameras and other instruments were trained on the sky at the same time for the observations. STIS dissected light from a quasar (the bright, active core of a distant galaxy). This light, which had traveled nearly three-quarters of the way across the heavens, provides a powerful three-dimensional probe of the universe's hidden structure. Invisible clouds of primeval hydrogen gas strung along billions of light-years between HST and the quasar are detectable in the signature of the light. The quasar is so brilliant it is like a searchlight shining through haze.

The Hubble Deep Field uncovered a plethora of odd-shaped, disrupted-looking galaxies. They offer direct evidence that galaxy collisions were more the rule than the exception in the early universe. Because collisions of distant galaxies are too faint and too small to study in much detail, the Telescope turned its gaze to a galactic wreck closer to home – the Antennae galaxies. A pair of long tails of luminous matter formed by a collision resembles an insect's antennae (see Fig. 3-10). The galaxies are 63 million light-years from Earth in the southern constellation Corvus.



K9322-310

Fig. 3-10 This HST image provides a detailed look at a "fireworks show" in the center of a collision between two galaxies.

At the heart of these colliding galaxies, the Telescope uncovered more than 1,000 bright, young star clusters bursting to life in a brief, intense, brilliant "fireworks show." By probing the Antennae and other colliding galaxies, Hubble has given astronomers a variety of surprises:

- Globular star clusters are not necessarily relics of the earliest generations of star formation in a galaxy. They may provide fossil records of more recent encounters.
- The "seeds" for star clusters appear to be giant molecular clouds of cold hydrogen gas, tens to hundreds of light-years across. The clouds are squeezed by surrounding hot gas heated during the galaxy collisions, then collapse under their own gravity. Like a string of firecrackers ignited by the collision, the reservoirs of gas light up in a great burst of star formation.
- The ages of the resulting clusters provide a clock for estimating the age of a collision. This offers an unprecedented opportunity for understanding, step by step, the complex sequence of events that occurs during an encounter and possibly even the evolution of spiral galaxies into elliptical galaxies.

Sometimes the debris from galaxy collisions is fodder for supermassive black holes. HST has given astronomers a peek at a feeding frenzy as a supermassive black hole in a nearby galaxy devours a smaller galaxy after the two collide. Such fireworks were common in the early universe, as galaxies formed and evolved, but are rare today.

The WFPC2 image of Centaurus A, also called NGC 5128, shows in sharp clarity a dramatic dark lane of dust

girdling the colliding galaxy (see Fig. 3-11). Blue clusters of newborn stars are clearly resolved, and silhouettes of dust filaments are interspersed with blazing orange-glowing gas. Located 10 million light-years away, this peculiar-looking galaxy contains the closest active galactic nucleus to Earth and has long been considered an example of an elliptical galaxy disrupted by a recent collision with a smaller companion spiral galaxy.



K9322-311

Fig. 3-11 Hubble offers an unprecedented close-up view of a turbulent firestorm of starbirth along a nearly edge-on dust disk girdling Centaurus A.

Using NICMOS, astronomers have penetrated this wall of dust for the first time to see a twisted disk of hot gas swept up in the black hole's gravitational whirlpool. The suspected black hole is so dense it contains the mass of perhaps a billion stars, compacted into a small region of space not much larger than our solar system.

Resolving features as small as seven light-years across, the Hubble has shown that the hot gas is tilted in a direction different from the axis of the black hole – like a wobbly wheel around an axle. This gas disk presumably fueling the black hole may have formed so recently that it has not yet become aligned with the black hole's spin axis, or it may simply be influenced more by the gravitational tug of the galaxy than by that of the black hole.

Still, scientists do not know if the black hole was always present in the host galaxy, if it belonged to the spiral galaxy that fell into the core, or if it is the product of the merger of a pair of smaller black holes that lived in the two once-separate galaxies.

From invisible black holes to the mysterious flashes of high-energy radiation called gamma ray bursts, Hubble is on the trail. These bright bursts of energy appear from random regions in space and typically last just a few seconds. U.S. Air Force Vela satellites first discovered gamma ray bursts in the 1960s. Since then, numerous theories of their origins have been proposed, but their causes remain unknown. The Telescope has helped astronomers trace them back to distant galaxies. The principal limitation in understanding the bursts was the difficulty in pinpointing their direction in the sky. Unlike visible light, gamma rays are exceedingly difficult to observe with a telescope, and their short duration exacerbates the problem.

Hubble has teamed up with several observatories, including X-ray satellites, to collect information on gamma ray bursts. The most energetic burst, GRB 971214, was detected December 14, 1997. Astronomers measured the distance to a faint galaxy from which the burst originated. Using the Italian/Dutch satellite BeppoSAX, they pinpointed the direction of the burst, which permitted follow-up observations with the world's most powerful telescopes.

The follow-up observations tracked GRB 971214's "afterglow" in radio waves, X-ray, visible, and infrared light. While gamma ray bursts last only a few seconds, their afterglows can be studied for several months. By analyzing afterglows, astronomers have discovered that the bursts do not originate within our own galaxy, the Milky Way, but are associated with extremely distant galaxies. The Hubble images of GRB 971214 confirmed the association of the burst's afterglow with a faint galaxy.

Astronomers still don't understand the origins of gamma ray bursts. Theories suggest they happen where vigorous star formation takes place. Whatever are the origins of gamma ray bursts, the Telescope has observed many of them, and in nearly every case they have been found to be associated with faint host galaxies.

3.4 Summary

The Hubble Space Telescope has established itself as a premier astronomical observatory that continues to make dramatic observations and discoveries at the forefront of astronomy. Following the successful First and Second Servicing Missions, the Telescope has achieved all of its original objectives. Among a long list of achievements, Hubble has:

- Improved our knowledge of the size and age of the universe
- Provided decisive evidence of the existence of supermassive black holes at the centers of galaxies
- Clearly revealed the galactic environments in which quasars reside
- Detected objects with coherent structure (protogalaxies) close to the time of the origin of the universe
- Provided unprecedentedly clear images and spectra of the collision of Comet Shoemaker-Levy 9 with Jupiter
- Detected a large number of protoplanetary disks around stars
- Elucidated the various processes by which stars form
- Provided the first map of the surface of Pluto

- Routinely monitored the meteorology of planets beyond the orbit of Earth
- Made the first detection of an ultraviolet high-energy laser in Eta Carinae.

After the Servicing Missions 3A and 3B, the Hubble Space Telescope will view the universe anew with significantly expanded scientific and technological capabilities.

SCIENCE INSTRUMENTS

Three instruments are currently in active scientific use on HST – the Wide Field and Planetary Camera 2 (WFPC2), the Space Telescope Imaging Spectrograph (STIS) and Fine Guidance Sensor 1R (FGS1R), which has been designated as the prime FGS for astrometric science. Other instrument bays are occupied by the Near Infrared Camera and Multi-Object Spectrometer (NICMOS), which is now dormant due to the depletion of its solid nitrogen cryogen; the Faint Object Camera (FOC), which is obsolete and has been decommissioned; and the corrective optical device called COSTAR, which is no longer needed.

During HST Servicing Mission 3B (SM3B) an experimental mechanical cooling system will be attached to NICMOS to determine if it can be brought back into operation. During the same mission the FOC will be replaced by the Advanced Camera for Surveys (ACS). COSTAR will be removed during the final HST servicing mission (SM4) to make room for the Cosmic Origins Spectrograph (COS).

The Fine Guidance Sensors (FGSs) are undergoing a systematic program of refurbishment and upgrading. In "round-robin" fashion, one FGS per servicing mission is being replaced, returned to the ground, disassembled and refurbished, and then taken back to HST on the next servicing mission to become the replacement unit for the next FGS to be serviced. In this manner, by the conclusion of SM4, all three FGSs will have been brought up to optimum condition.

4.1 Space Telescope Imaging Spectrograph

STIS was developed under the direction of the principal investigator, Dr. Bruce E. Woodgate, jointly with Ball Aerospace (see Fig. 4-1). The spectrograph was designed to be versatile and efficient, taking advantage of modern technologies to provide a new two-dimensional capability to HST spectroscopy. The two dimensions can be used either for "long slit" spectroscopy, where spectra of many different points across an object are obtained simultaneously, or in an echelle mode to obtain more wavelength coverage in a single exposure. STIS also can take both UV and visible images through a limited filter set.

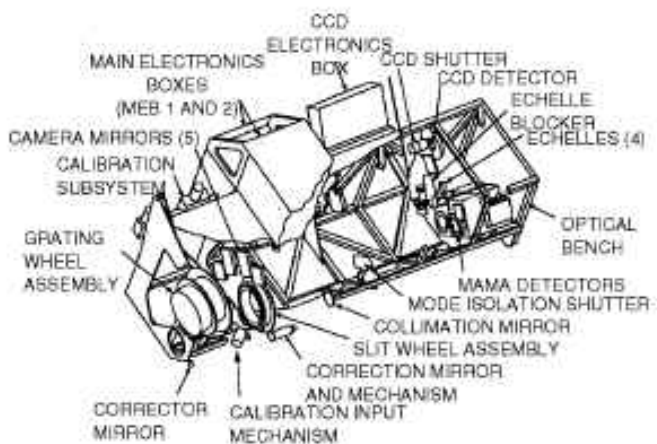

K70110-407

Fig. 4-1 Space Telescope Imaging Spectrograph

STIS was designed to replace many of the capabilities of the instruments it succeeded on SM2 – the Goddard High Resolution Spectrograph and the Faint Object Spectrograph. However, it has additional enhanced capabilities. STIS covers a broader wavelength range with two-dimensional capability, adds a coronagraph capability, and has a high time-resolution capability in the UV. It also can image and can provide objective prism spectra in the intermediate

UV. STIS carries its own aberration-correcting optics.

4.1.1 Physical Description

STIS resides in an axial bay behind the HST main mirror. Externally, the instrument measures 7.1 x 2.9 x 2.9 ft (2.2 x 0.98 x 0.98 m) and weighs 825 lb (374 kg). Internally, STIS consists of a carbon fiber optical bench, which supports the dispersing optics and three detectors.

STIS has been designed to work in three different wavelength regions, each with its own detector. Some redundancy is built into the design with overlap in the detector response and backup spectral modes. To select a wavelength region or mode, a single mechanism, called the mode selection mechanism (MSM), is used. The MSM has 21 optical elements: 16 first-order gratings (six of which are order-sorting gratings used in the echelle modes), an objective prism, and four mirrors. The optical bench supports the input corrector optics, focusing and tip/tilt motions, the input slit and filter wheels, and the MSM.

Light from the HST main mirror is first corrected and then brought to a focus at the slit wheel. After passing through the slit, it is collimated by a mirror onto one of the MSM optical elements. A computer selects the mode and wavelength. The MSM rotates and nutates to select the correct optical element, grating, mirror, or prism, and points the beam along the appropriate optical path to the correct detector.

In the case of first-order spectra, a first-order grating is selected for the wavelength and dispersion. The beam then is pointed to a camera mirror, which focuses the spectrum onto the detector, or goes directly to the detector itself.

For an echelle spectrum, an order-sorting grating that directs the light to one of the four fixed echelle gratings is selected, and the dispersed echellogram is focused via a camera mirror onto the appropriate detector. The detectors are housed at the rear of the bench, so they can easily dissipate heat through an outer panel. The optical bench is thermally controlled. An onboard computer controls the detectors and mechanisms.

Each of the three detectors has been optimized for a specific wavelength region. Band 1, from 115 to 170 nm, uses a Multi-Anode Microchannel Plate Array (MAMA) with a cesium iodide (CsI) photocathode. Band 2, from 165 to 310 nm, also uses a MAMA but with a cesium telluride (CsTe) photocathode. Bands 3 and 4, covering the wavelengths from 305 to 555 nm and 550 to 1000 nm, use the same detector, a charge-coupled device (CCD). Figure 4-2 shows the instrument schematically.

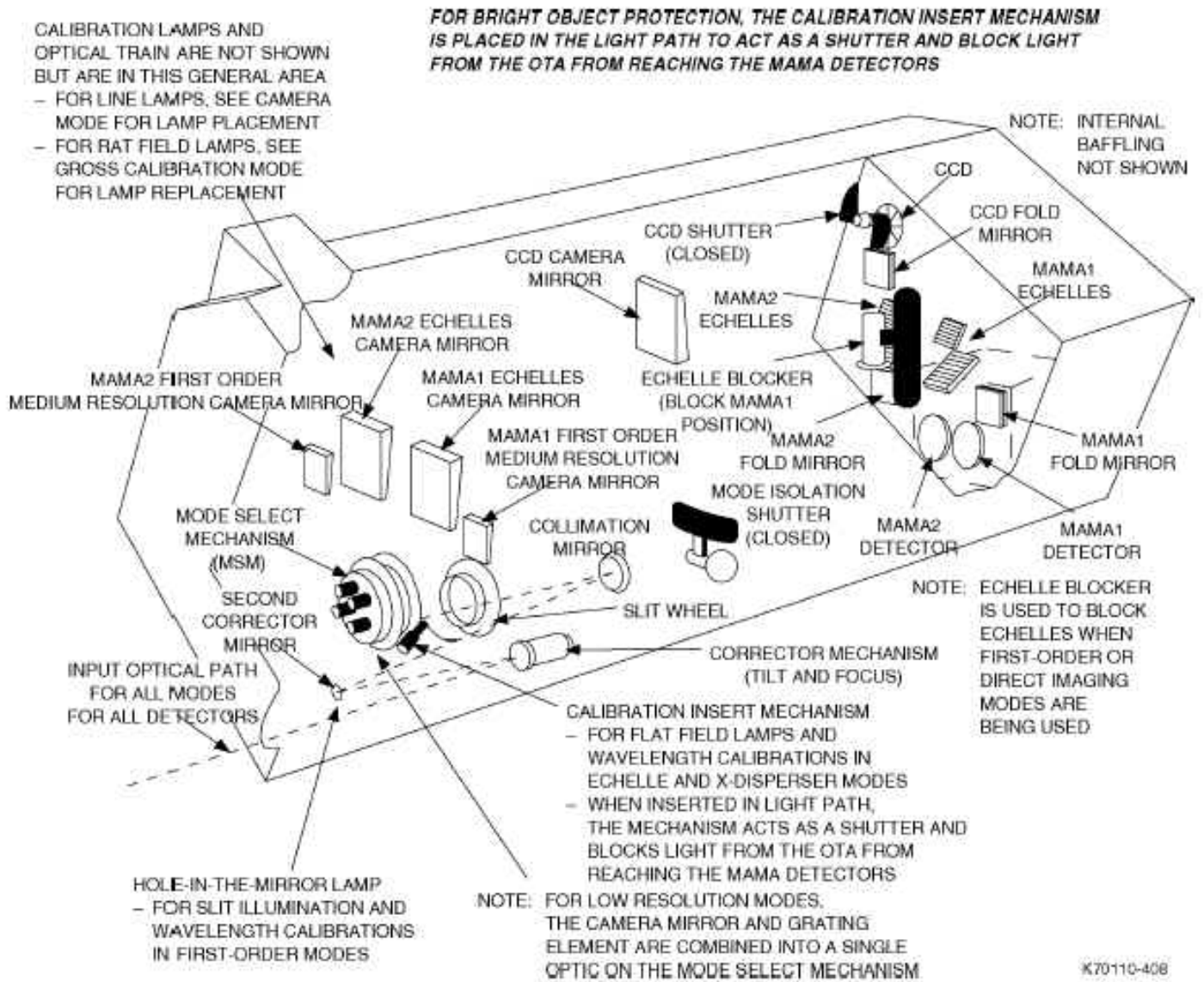

Fig. 4-2 STIS components and detectors

Entrance Apertures.

After the light beam passes through the corrector, it enters the spectrograph through one of several slits. The slits are mounted on a wheel and the slit or entrance aperture can be changed by wheel rotation.

The first-order spectral imaging modes can select slits 50 arcsec long and from 0.05 to 2 arcsec wide. Three slits have occulting bars that can block out a bright star in the field. Four slits are tilted to an angle of 45 degrees for planetary observations. For echelle spectroscopy, 16 slits ranging in length from 0.10 to 1 arcsec are available. The slit length is short to control the height of the echelle spectra in the image plane and avoid spectral order overlap. The echelle slits have widths of 0.05, 0.10, 0.12, 0.20, and 0.5 arcsec. There also are camera apertures of 50 x 50 and 25 x 25 arcsec. Some of the apertures have occulting bars incorporated. The telescope can be positioned to place bright stars behind the occulting bars to allow viewing and observation of faint objects in the field of view. In addition, there is a special occulting mask or coronagraph, which is a finger in the aperture that can be positioned over a bright star to allow examination of any faint material nearby.

It can be thought of as a simulation of a total eclipse on a nearby star. This mode is particularly useful to search for faint companion stars or planetary disks around stars.

Mode Selection Mechanism.

The mode selection mechanism (MSM) is a rotating wheel that has 16 first-order gratings, an objective prism, and four mirrors mounted to it. The MSM axis is a shaft with two inclined outer sleeves, one sleeve fitting inside the other. The sleeves are constructed so that rotation of one sleeve rotates a wheel to orient the appropriate optic into the beam. Rotation of the second sleeve changes the inclination of the axis of the wheel or tilt of the optic to select the wavelength range and point the dispersed beam to the corresponding detector. One of three mirrors can be selected to take an image of an object. The objective prism is used exclusively with the Band 2 MAMA (see Fig. 4-3). Of the 16 gratings, six are cross dispersers that direct dispersed light to one of the four echelle gratings for medium- and high-resolution modes.

Mode	Band Wavelength Range (nm) Detector	Band 1 115-170 Det #1 (MAMA/CsI)	Band 2 165-310 Det #2 (MAMA/Cs ₂ Te)	Band 3 305-555 Det #3 (CCD)	Band 4 550-1000 Det #4 (CCD)
Low resolution spectral imaging (first order)	Mode number Resolving power (RDI) Slit length (arcsec) Exposures/band	1.1 770-1,130 24.0 1	2.1 415-730 24.0 1	3.1 445-770 51.1 1	4.1 425-680 51.1 1
Medium resolution spectral imaging (first order scanning)	Mode number Resolving power (RDI) Slit length (arcsec) Exposures/band	1.2 8,600-12,800 29.7 11	2.2 7,500-13,800 29.7 18	3.2 4,840-7,730 51.1 10	4.2 3,760-6,220 51.1 9
Medium resolution echelle	Mode number Resolving power (RDI) Exposures/band	1.3 37,000 1	2.3 23,400-23,100 2	—	—
High resolution echelle	Mode number Resolving power (RDI) Exposures/band	1.4 100,000 3	2.4 100,000 6	—	—
Objective spectroscopy (prism)	Mode number Resolving power (RDI) Field of view (arcsec)	—	2.5 (115-310 nm) 900-26 (at 120-310) 29.7 x 29.7	—	—

K70119-409

Fig. 4-3 STIS spectroscopic modes

Multi-Anode Microchannel Plate Array Detectors.

For UV modes, two types of MAMA detectors are employed on STIS. A photo-cathode optimizes each detector to its wavelength region. Each detector's photocathode Fig. 4-2 STIS components and detectors.K9322-04M 4-4 provides maximum sensitivity in the wave-length region selected, while it rejects visible light not required for the observations. The Band 1 MAMA uses a CsI cathode, which is sensitive to the wavelength region from 115 to 170 nm and very insensitive to wavelengths in the visible. Similarly, the Band 2 MAMA uses a CsTe photocathode, which is sensitive to the wavelength region from 120 to 310 nm.

The heart of each MAMA detector is a microchannel plate (MCP) – a thin disk of glass approximately 1.5 mm thick and 5 cm in diameter that is honeycombed with small (12.5-micron) holes or pores. The front and back surfaces are metal coated. With a voltage applied across the plate, an electron entering any pore is accelerated by the electric field, and it eventually collides with the wall of the pore, giving up its kinetic energy to liberate two or more secondary electrons. The walls are treated to enhance the secondary electron production effect. The secondary electrons continue down the pore and collide with the wall to emit more electrons, and so the process continues, producing a cascade of a million electrons at the end of the pore.

In the Band 1 tube, shown in Fig. 4-4, UV photons enter and hit the CsI photocathode that is deposited on the front surface of the MCP. The cathode produces an electron when a photon hits it and the electron is accelerated into the MCP pores. The MCP amplifies the number of electrons, which fall as a shower onto the anode array as they leave the MCP.

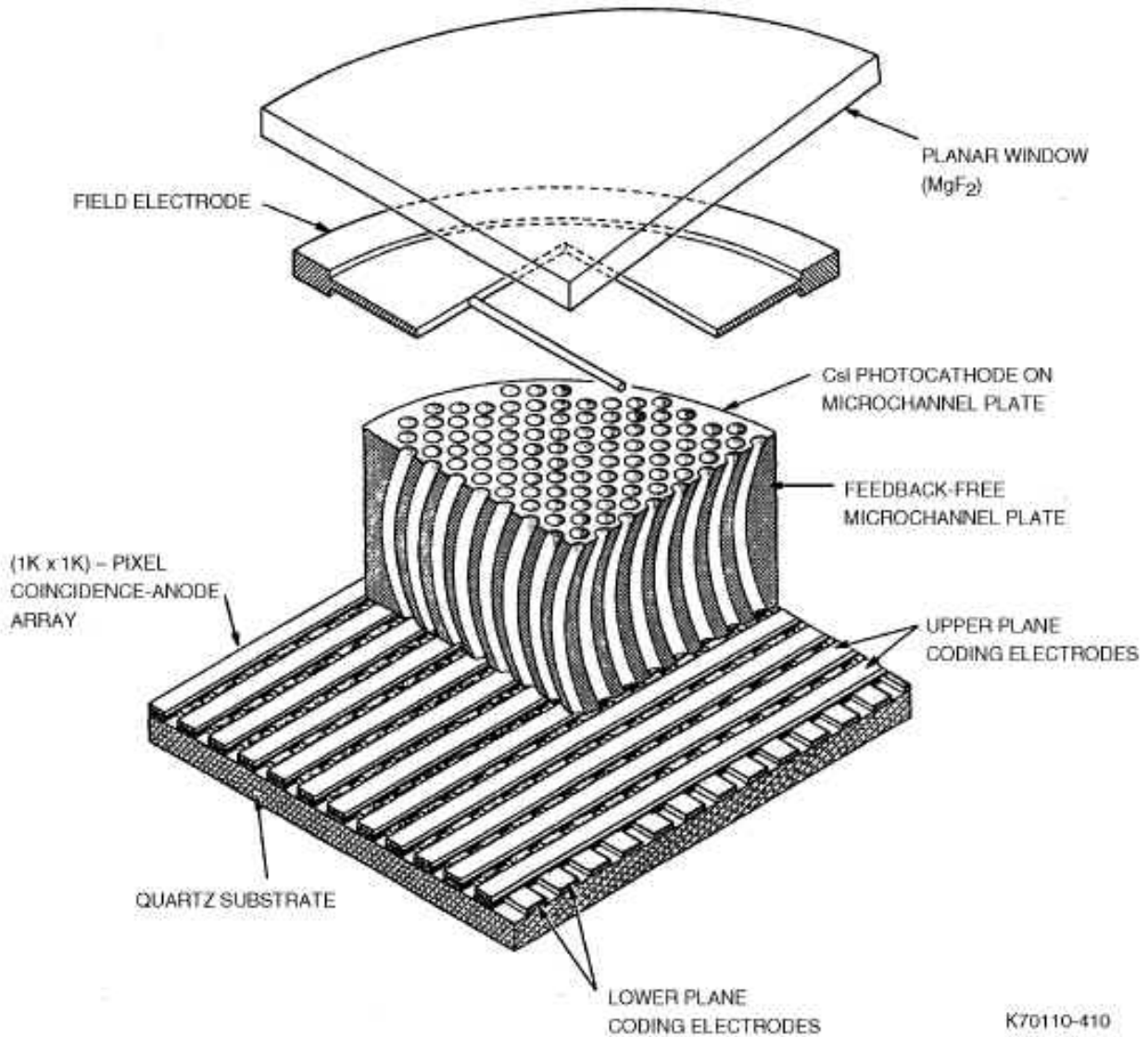
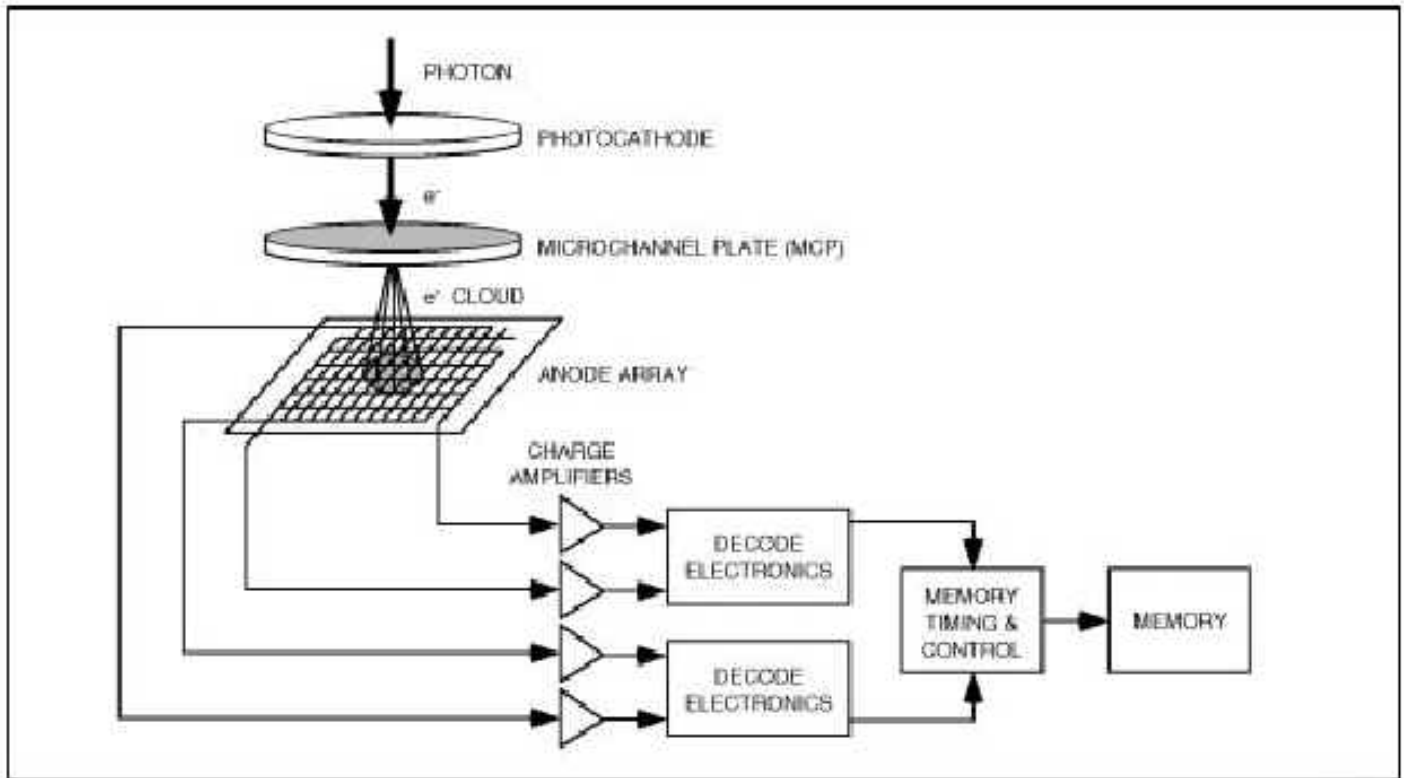

Fig. 4-4 Multi-Anode Microchannel Plate Array (MAMA) detector

The anode array is a complex fingerlike pattern. When electrons strike certain anodes, a signal is sent to the computer memory indicating the position and time of arrival of the photon. Figure 4-5 shows the detection scheme in simplified form.



K7Q11-911

Fig. 4-5 Simplified MAMA system

The anode array has been designed so that only 132 circuits are required to be able to read out all 1024 x 1024 pixels. As the MAMA records the arrival of each photon, it can provide a time sequence. For instance, if an object is varying in time, like a pulsar, the data can be displayed to show if there is any periodicity. Similarly, to create an image, the data must be integrated in the computer memory before it is displayed. The MAMA data is recorded to a time resolution of 125 microseconds.

In the case of Band 2, the CsTe photocathode is deposited on the inside surface of the front window as a semi-transparent film. Photons pass through the window, and some are stopped in the cathode film where they generate electrons, which are amplified and detected in the same manner as the Band 1 detector.

When used in the normal mode, each detector has 1024 x 1024 pixels, each 25 x 25 microns square. However, data received from the anode array can be interpolated to give a higher resolution, splitting each pixel into four 12.5 x 12.5 micron pixels. This is known as the high-resolution mode; however, data taken in this mode can be transformed to normal resolution if required. The high-resolution mode provides higher spatial resolution for looking at fine structural details of an object and ensures full sampling of the optical images and spectra.

Charge-Coupled Detector.

The STIS CCD was developed with GSFC and Ball input at Scientific Imaging Technologies (SITE). Fabricated using integrated circuit technology, the detector consists of light-sensitive picture elements (pixels) deposited onto a thin wafer of crystalline silicon. Each element is 21 x 21 microns. The elements are arranged 1024 to a row, in 1024 columns. The 1024 x 1024 format contains 1,048,576 pixels.

Each element acts as a small capacitance. As light falls on a pixel, it liberates electrons, which effectively charge the capacitance. The number of electrons stored is then proportional to the intensity or brightness of the light received. The charge in each pixel can be read out by applying a small voltage across the chip.

The CCD is most sensitive to red light, but the STIS chip has been enhanced through what is known as a "backside treatment" to provide a usable sensitivity in the near-ultraviolet. The CCD is sensitive from approximately 200 nm to the near infrared at 1000 nm. The violet extension allows the CCD to overlap with the Band 2 MAMA sensitivity and can serve as a backup detector.

To reduce thermionic noise generated in the CCD, the detector is integrated into a housing and cooled to below -80°C. The cooling is provided by a thermoelectric cooler, which is bonded onto the back of the CCD. The heat extracted from the CCD is dissipated through a radiative cooling panel on the outside of STIS. The housing has a front window made from fused silica and is kept close to 20°C, the design temperature of the optical bench.

The CCD can make exposures ranging from 0.1 seconds to 60 minutes. In space, above Earth's protective atmosphere, radiation from cosmic rays is higher than at Earth's surface. CCDs are sensitive to cosmic rays, which can produce large numbers of electrons in the pixels. For this reason, two shorter exposures of up to 1 hour are made and comparison of the frames allows cosmic ray effects to be subtracted.

The CCD is a 16-bit device, allowing a dynamic range from 1 to 65,535 to be recorded. Changing the gain can further extend the dynamic range. The gain is commandable for 1 electron/bit to 8 electrons/bit.

Another useful feature is called binning, in which pixels are merged on the chip. Typically, binning is 2 x 2 for imaging, making the pixels larger, which can reduce the noise per pixel and increase sensitivity at the cost of resolution. Binning can be used to look for extended faint objects such as galaxies. Another binning application is in the long-slit mode on extended faint objects. In this mode, binning along the slit by 1 x 4, for instance, would maintain the spectral resolution but sum the spectra from different parts of an object seen along the slit to increase signal or detectivity.

Finally, to increase the CCD's performance at low light levels, the chip has incorporated a minichannel. The main problem with reading out a signal from a CCD is that a charge generated by light must be dragged across the chip, through all its adjacent pixels, to be read out of one corner. In so doing, the charge meets spurious defects in each pixel that add noise. Because the noise can be very path dependent, the minichannel ion implant is designed to restrict the path taken at low signal levels to improve CCD performance.

4.1.2 Spectra Operational Modes

Figure 4-3 shows the spectral operational modes. Two numbers, W and R, describe each instrument mode, where W refers to the wave-length range and R to the resolving power.

The low-resolution, or spectral-imaging mode, is R~500 to 1,000, and can be carried out in all four bands using a long slit. The medium resolution mode, R~5,000 to 10,000, is a spectral imaging mode that can be carried out in all four bands using long slits. However, as dispersion increases, not all of the spectrum falls on the detector. Obtaining an entire spectral range may require moving the spectrum and taking another image. Figure 4-3 indicates the number of exposures to cover the whole wavelength range.

The medium-resolution echelle spectroscopy with R~24,000 uses short slits and is available in the UV only. Band 2 requires two exposures to cover the whole wavelength region.

High-resolution echelle spectroscopy, with R~100,000, uses short slits and is available in the UV only. Both Bands 1 and 2 require multiple exposures.

Objective spectroscopy, R~26 (at 300 nm) and 930 (at 121 nm), is available using the Band 2 detector only. This mode uses a prism instead of a grating. The prism dispersion, unlike a grating, is not uniform with wavelength. The low-resolution gratings and the prism also can provide imaging spectroscopy of emission line objects such as planetary nebulae, supernova remnants, or active galaxies.

Imaging Operational Modes.

STIS can be used to acquire an image of an object in UV or visible light. To do this, an open aperture is selected and a mirror placed in the beam by the MSM. The instrument has nine filters that can be selected (see Fig. 4-6). The cameras for the CCD and the MAMAs have different magnification factors. The field of view is 25 x 25 arcsec for the MAMAs and 50 x 50 arcsec for the CCD.

Filter Type	Central or Cutoff Wavelength	FWHM (nm)	Peak Transmission (%)
Emission line (Lyman α)	122 nm	8.5	10
Cutoff (SrF ₂ crystal)	>128 nm	N/A	90
Cutoff (crystalline quartz)	>146 nm	N/A	85
Continuum	182 nm	49	40
Emission line (C III)	191 nm	15	15
Continuum	270 nm	22.8	72
Emission line (Mg II)	280 nm	5.6	65
Emission line (O II)	373 nm	7.1	53
Emission line (O III)	501 nm	0.6	73

K70110-412

Fig. 4-6 STIS filter set

Target Acquisition.

Normally an object is acquired using the CCD camera with a 50 x 50- arcsec field. Two short exposures are taken to enable subtraction of cosmic rays. The HST FGSs have a pointing accuracy of ± 2 arcsec, and the target usually is easily identifiable in the field. Once identified, an object is positioned via small angle maneuvers to the center of the chosen science mode slit position. Two more exposures are made, and then the calibration lamp is flashed through the slit to confirm the exact slit position. A further peak up on the image is then performed. Acquisition can be expected to take up to approximately 20 minutes.

Data Acquisition. The MAMAs take data in the high-resolution mode. For normal imaging and spectroscopy, the data will be integrated in the onboard computer and stored in this format on the solid-state recorders for later downlink. The MAMAs also have a time-tag mode, where each photon is stored individually with its arrival time and location (x, y, t). The data is stored in a 16-Mb memory and as the memory fills, the data is dumped into the onboard recorder. The time-tag mode has a time resolution of 125 microseconds.

4.1.3 STIS Specifications

Figure 4-7 shows STIS specifications.

Space Telescope Imaging Spectrograph (STIS)	
Weight	825 lb (374 kg)
Dimensions	3 x 3 x 7 ft (0.9 x 0.9 x 2.2 m)
Principal investigator	Dr. Bruce E. Woodgate, GSFC
Prime contractor	Ball Aerospace
Field of view	MAMA: 24.9 x 24.9 arcsec CCD: 51 x 51 arcsec
Pixel format	1024 x 1024
Wavelength range	115 to 1000 nanometers

K70110-413

Fig. 4-7 STIS specifications

4.1.4 Observations

Scientists using STIS focus their science on many areas, including:

- Search for massive black holes by studying star and gas dynamics around the centers of galaxies
- Measurement of the distribution of matter in the universe by studying quasar absorption lines
- Use of the high sensitivity and spatial resolution of STIS to study stars forming in distant galaxies
- Mapping – giving fine details of planets, nebulae, galaxies, and other objects
- Coronagraphic capability may enable it to image Jupiter-sized planets around nearby stars. STIS also can provide physical diagnostics, such as chemical composition, temperature, density, and velocity of rotation or internal mass motions in planets, comets, stars, interstellar gas, nebulae, stellar ejecta, galaxies, and quasars.

Studies of Black Holes in Centers of Galaxies.

A black hole was discovered in the center of M87 using FOS. The black hole's mass provides the gravity required to hold in orbit gas and stars that are rapidly rotating about the galactic nucleus. From the spectra of stars surrounding the nucleus, a measure of how rapidly the velocity changes from one side of the nucleus to the other can be determined by measuring the Doppler shift. STIS's long-slit mode is particularly well suited for this type of measurement because all the spatial positions required can be measured along the slit in a single exposure. With STIS, a study of black holes can be made easily for many galaxies and compared from one galaxy to another.

Abundances and Dynamics of the Intergalactic Medium.

STIS is well suited to observe the spectra of distant galaxies and quasars. Absorption lines from intervening material in the spectra of these objects give a measure of the dynamics and abundances of specific elements. However, because these objects are distant, we effectively are looking back in time to an earlier stage of the universe when the chemical composition was different from that seen in the vicinity of our Sun today. Measuring these differences can provide important clues to how the universe has evolved over time.

Abundances in the Interstellar Medium.

The STIS high-resolution mode is particularly well suited to measurements of the spectral absorption lines created in the interstellar medium and seen against distant O- and B-type stars. From the Doppler shift, a measure of gas speed is obtained. Temperature and density and chemical composition also can be measured. The interstellar medium is thought to play an important role in when star formation occurs in galaxies. Current theories point to hot material being expelled from supernovas into a galaxy's surrounding halo. Later, after cooling, the material returns to the galactic plane and eventually forms new stars. How quickly the interstellar medium circulates can be a clue to when star formation occurs.

Search for Protoplanetary Disks.

STIS's coronagraphic mode can be used to image nearby stars and search for protoplanetary disks. These observations provide complementary data to NICMOS, which was to peer through the thick dust around young stars. These observations shed light on how planets form, what type of stars have planetary disks, and how quickly the disks evolve into planets.

4.2 Wide Field and Planetary Camera 2

Hubble's "workhorse" camera is WFPC2. It records two-dimensional images at two magnifications through a selection of 48 color filters covering a spectral range from far-ultraviolet to visible and near-infrared wavelengths. It provides pictorial views of the celestial universe on a grander scale than any other instrument flown to date. Like its predecessor WFPC1, WFPC2 was designed and built at NASA's Jet Propulsion Laboratory (JPL), which is operated by the California Institute of Technology. Professor James A. Westphal of Caltech was the principal investigator for WFPC1. Dr. John T. Trauger of JPL is the principal investigator for WFPC2.

WFPC1, the first-generation instrument, was launched with the Telescope in 1990 and functioned flawlessly. The second-generation instrument, WFPC2, was already under construction when the Hubble Telescope was launched. Its original purpose was to provide a backup for WFPC1 with certain enhancements, including an upgraded set of filters, advanced detectors, and improved UV performance. With modifications introduced after 1990, WFPC2 also provided built-in compensation for the improper curvature of the Telescope's primary mirror so as to achieve the originally specified imaging performance of the Telescope in the WFPC2 field of view.

WFPC2 has four CCD cameras arranged to record simultaneous images in four separate fields of view at two magnifications.

In three Wide Field Camera fields, each detector picture element (pixel) occupies 1/10th arcsec, and each of the three detector arrays covers a square 800 pixels on a side (or 80 arcsec, slightly more than the diameter of Jupiter when it is nearest the Earth). The Telescope is designed to concentrate 70 percent of the light of a star image into a circle 0.2 arcsec (or two Wide Field Camera pixels) in diameter. This three-field camera (which operates at a focal ratio of f/12.9) provides the greatest sensitivity for the detection of faint objects. Stars as faint as 29th magnitude are detectable in the longest exposures (29th magnitude is over one billion times fainter than can be seen with the naked eye).

The Planetary Camera provides a magnification about 2.2 times larger, in which each pixel occupies only 0.046 arcsec, and the single square field of view is only 36.8 arcsec on a side. It operates at a focal ratio of f/28.3. Originally incorporated for studying the finest details of bright planets, the Planetary Camera actually provides the optimum sampling of the Telescope's images at visible wavelengths and is used (brightness permitting) whenever the finest possible spatial resolution is needed, even for stars, stellar systems, gaseous nebulae, and galaxies.

With its two magnifications and its built-in correction for the Telescope's spherical aberration, WFPC2 can resolve

the fine details and pick out bright stellar populations of distant galaxies. It can perform precise measurements of the brightness of faint stars, and study the characteristics of stellar sources even in crowded areas such as globular clusters – ancient swarms of as many as several hundred thousand stars that reside within a huge spherical halo surrounding the Milky Way and other galaxies – that could not be studied effectively with WFPC1 because of the aberration. WFPC2's high-resolution imagery of the planets within our solar system allows continued studies of their atmospheric composition as well as discovery and study of time-varying processes on their surfaces.

4.2.1 Physical Description

The WFPC2 occupies one of four radial bays in the focal plane structure of the HST. The other three radial bays support the FGSs, which are used primarily for controlling the pointing of the Telescope.

The WFPC2's field of view is located at the center of the Telescope's field of view, where the telescopic images are nearly on axis and least affected by residual aberrations (field curvature and astigmatism) that are inherent in the Ritchey-Chretien design.

Because the focal plane is shared by the other instruments, WFPC2 is equipped with a flat pickoff mirror located about 18 in. ahead of the focal plane and tipped at almost 45 degrees to the axis of the Telescope. The pickoff mirror is attached to the end of a stiff truss, which is rigidly fastened to WFPC's precisely located optical bench. The pickoff mirror reflects the portion of the Telescope's focal plane belonging to WFPC2 into a nearly radial direction, from which it enters the front of the instrument, allowing light falling on other portions of the focal plane to proceed without interference.

WFPC2 is shaped somewhat like a piece of pie, the pickoff mirror lying at the point of the wedge, with a large, white-painted cylindrical panel 2.6 ft (0.8 m) high and 7 ft (2.2 m) wide at the wide end. The panel forms part of the curved outer skin of the Support Systems Module (SSM) and radiates away the heat generated by WFPC's electronics. The instrument is held in position by a system of latches and is clamped in place by a threaded fastener at the end of a long shaft that penetrates the radiator and is accessible to the astronauts.

WFPC2 weighs 619 lb (281 kg). The cameras comprise four complete optical subsystems, four CCDs, four cooling systems using thermoelectric heat pumps, and a data-processing system to operate the instrument and send data to the SI C&DH unit. Figure 4-8 shows the overall configuration of the instrument.

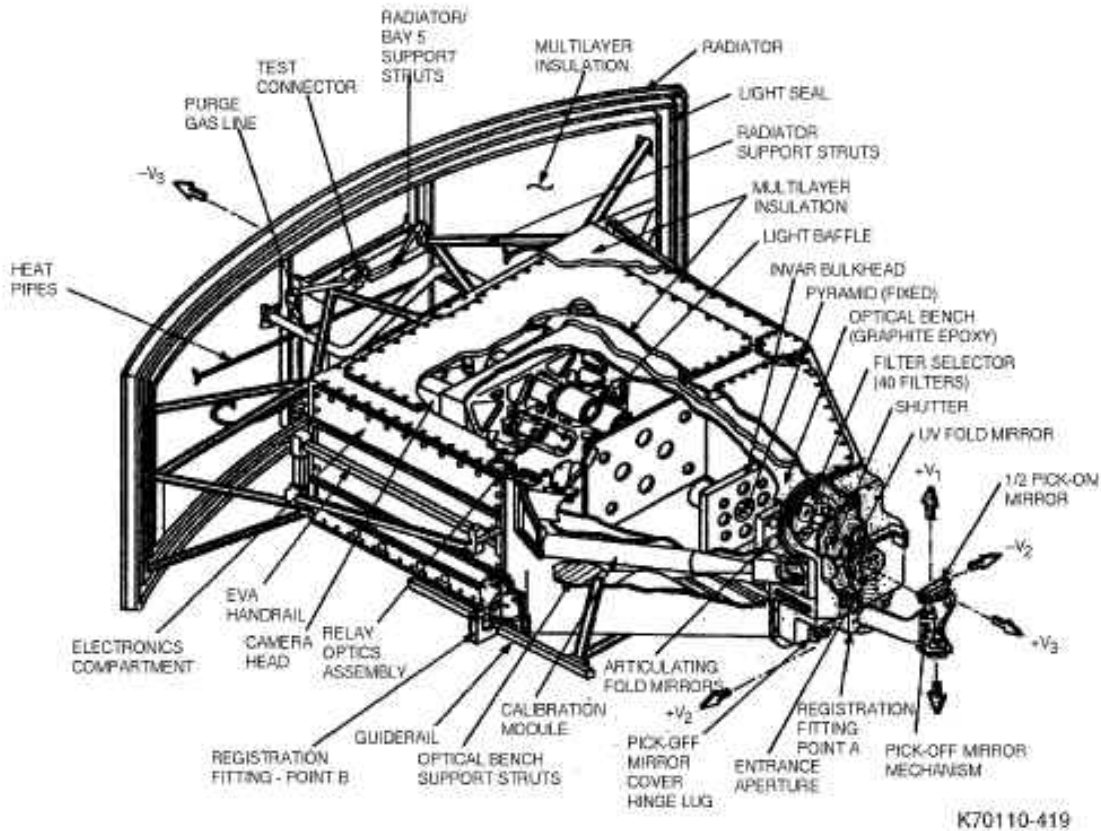

Fig. 4-8 Wide Field and Planetary Camera (WFPC) overall configuration

Optical System.

The WFPC2 optical system consists of the pickoff mirror, an electrically operated shutter, a selectable optical filter assembly, and a four-faceted reflecting pyramid mirror used to partition the focal plane to the four cameras. Light reflected by the pyramid faces is directed by four "fold" mirrors into each of four two-mirror relay cameras. The relays re-image the Telescope's original focal plane onto the four detector arrays while providing accurate correction for the spherical aberration of the Telescope's primary mirror. Figure 4-9 shows the light path from the Telescope to the detectors.

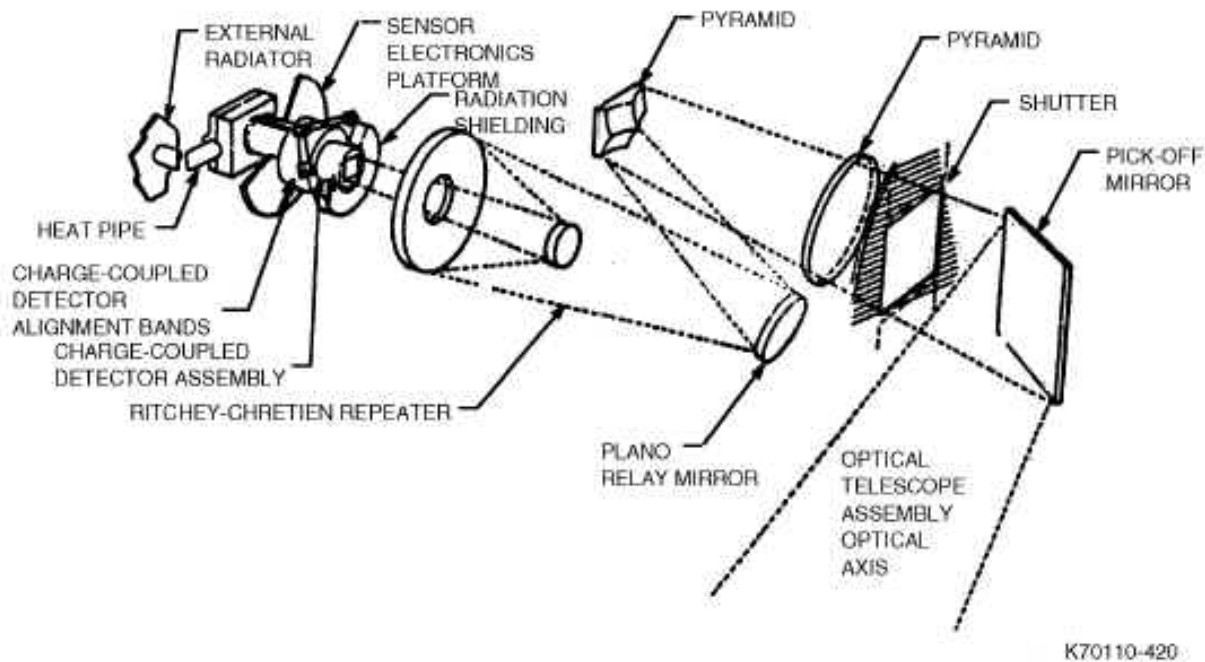

Fig. 4-9 WFPC optics design

As in an ordinary camera, the shutter is used to control the exposure time, which can range from about 1/10th second to 28 hours. Typical exposure times are 45 minutes, about the time required for the Telescope to complete half an orbit.

WFPC2's pickoff mirror and three of its four fold mirrors are equipped with actuators that allow them to be controlled in two axes (tip and tilt) by remote control from the ground. The actuators ensure that the spherical aberration correction built into WFPC2 is accurately aligned relative to the Telescope in all four channels.

The Selectable Optical Filter Assembly (SOFA) consists of 12 independently rotatable wheels, each carrying four filters and one clear opening, for a total of 48 filters. These can be used singly or in certain pairs. Some of the WFPC2's filters have a patchwork of areas with differing properties to provide versatility in the measurement of spectral characteristics of sources.

WFPC2 also has a built-in calibration channel, in which stable incandescent light sources serve as references for photometric observations.

Charge-Coupled Detectors.

ACCD is a device fabricated by methods developed for the manufacture of integrated electronic circuits. Functionally, it consists of an array of light-sensitive picture elements (pixels) built upon a thin wafer of crystalline silicon. Complex electronic circuits also built onto the wafer control the light-sensitive elements. The circuits include low-noise amplifiers to strengthen signals that originate at the light sensors. As light falls upon the array, photons of light interact with the sensor material to create small electrical charges (electrons) in the material. The charge is very nearly proportional to the number of photons absorbed. The built-in circuits read out the array, sending a succession of signals that will allow later Fig. 4-9 WFPC optics design.4-13 K9322-04M reconstruction of the pattern of incoming light on the array. Figure 4-10 illustrates the process.

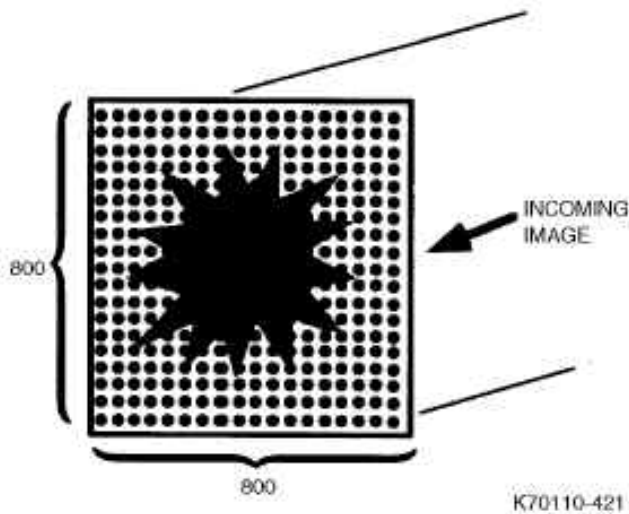

Fig. 4-10 WFPC2 imaging

The CCDs used in WFPC2 consist of 800 rows and 800 columns of pixels, 640,000 pixels in each array. The pixels can be thought of as tiny squares side by side, 15 microns (about 6/10,000 in.) on a side. Their sensitivity to light is greatest at near-infrared and visible wavelengths, but in WFPC2 it is extended to the UV by coating them with a thin fluorescent layer that converts UV photons to visible ones.

To achieve a very low-noise background that does not interfere with measurements of faint astronomical light sources, the CCDs must be operated at a low temperature, approximately -50 to -70°C (-8 to -130°F). This is accomplished by an electrically operated solid-state cooling system that pumps heat from the cold CCDs to the warmer external radiator by means of heat pipes. The radiator faces away from the Earth and Sun so that its heat can be effectively radiated into the cold vacuum of space.

CCDs are much more sensitive to light than photographic film and many older forms of electronic light sensors. They also have finer resolution, better linearity, and ability to convert image data directly into digital form. As a result, CCDs have found many astronomical and commercial applications following their early incorporation in WFPC1.

Processing System.

A microprocessor controls all of WFPC2's operations and transfers data to the SI C&DH unit. Commands to control various functions of the instrument (including filter and shutter settings) are sent by radio uplink to the Telescope in the form of detailed encoded instructions originated at the Space Telescope Science Institute (STScI) in Baltimore, Maryland. Because the information rate of the Telescope's communication system is limited, the large amount of data associated with even one picture from WFPC2 is digitally recorded during the CCD readout. The data then is transmitted at a slower rate via a communications satellite that is simultaneously in Earth orbit.

4.2.2 WFPC2 Specifications

Figure 4-11 shows the WFPC2 specifications.

Wide Field and Planetary Camera 2	
Weight	610 lb (281 kg)
Dimensions	Camera: 9.3 x 6 x 1.7 ft (1 x 1.3 x 0.5 m), Fluorator: 2.6 x 7 ft (0.8 x 2.2 m)
Principal investigator	John Trauger, Jet Propulsion Laboratory
Contractor	Jet Propulsion Laboratory
Optical modes	f/2.9 (WF), f/20.0 (PC)
Field of view	4.7 arcmin ² (WF), 0.3 arcmin ² (PC)
Magnitude range	9 to 25 m _v
Wavelength range	1200 to 10,000 angstroms

K70110-422A

Fig. 4-11 WFPC2 specifications

4.2.3 Observations

The WFPC2 can perform several tasks while observing a single object. It can focus on an extended galaxy and take a wide-field picture of the galaxy, then concentrate on the galaxy nucleus to measure light intensity and take photographic closeups of the center. In addition, the WFPC2 can measure while other instruments are observing.

Specific applications of this camera range from tests of cosmic distance scales and universe expansion theories to specific star, supernova, comet, and planet studies. Important searches are being made for black holes, planets in other star systems, atmospheric storms on Mars, and the connection between galaxy collisions and star formation.

4.3 Astrometry (Fine Guidance Sensors)

When two FGSs lock on guide stars to provide pointing information for the Telescope, the third FGS serves as a science instrument to measure the position of stars in relation to other stars. This astrometry helps astronomers determine stellar masses and distances.

Fabricated by Raytheon Optical Systems Inc., the sensors are in the focal plane structure, at right angles to the optical path of the Telescope and 90 degrees apart. They have pickoff mirrors to deflect incoming light into their apertures, as shown in Fig. 4-12. (See para 5.3 for more details.)

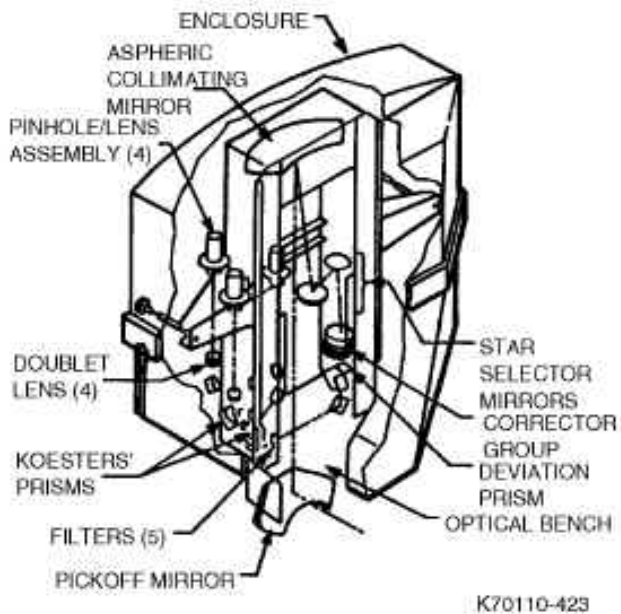

Fig. 4-12 Fine Guidance Sensor (FGS)

Each refurbished FGS has been upgraded by the addition of an adjustable fold mirror (AFM). This device allows HST's optical beam to be properly aligned to the internal optics of the FGS by ground command. The first-generation FGSs did not contain this feature and their optical performance suffered as a consequence. During Servicing Mission 2, FGS 1 was removed from HST and replaced with FGS 1R, the first FGS to feature this active alignment capability. Now with its optical system properly aligned, FGS 1R performs superbly and is the prime instrument on HST for astrometric science observations.

4.3.1 Fine Guidance Sensor Specifications

Figure 4-13 shows FGS specifications.

Fine Guidance Sensor	
Weight	485 lb (220 kg)
Dimensions	1.6 x 3.3 x 5.4 ft (0.5 x 1 x 1.6 m)
Contractor	Raytheon Optical Systems Inc.
Astrometric modes	Stationary and moving target, scan
Precision	0.002 arcsec ²
Measurement speed	10 stars in 10 minutes
Field of view	Access: 60 arcmin ² Detect: 5 arcsec
Magnitude range	4 to 18.5 m _v
Wavelength range	4670 to 7000 angstroms

K70110-424A

Fig. 4-13 FGS specifications

4.3.2 Operational Modes for Astrometry

Once the two target-acquisition FGSs lock onto guide stars, the third sensor can perform astrometric operations on targets within the field of view set by the guide stars' positions. The sensor should be able to measure stars as faint

as 18 apparent visual magnitude.

There are three operational modes for astrometric observations: position, transfer-function, and moving-target. Position mode allows the astrometric FGSs to calculate the angular position of a star relative to the guide stars. Generally, up to 10 stars will be measured within a 20-minute span.

In the transfer-function mode, sensors measure the angular size of a target, either through direct analysis of a single-point object or by scanning an extended target. Examples of the latter include solar system planets, double stars, and targets surrounded by nebulous gases.

Astrometric observations of binary stars provide information about stellar masses which is important to understanding the evolution of stars.

In moving-target mode, sensors measure a rapidly moving target relative to other targets when it is impossible to precisely lock onto the moving target; for example, measuring the angular position of a moon relative to its parent planet.

4.3.3 Fine Guidance Sensor Filter Wheel

Each FGS has a filter wheel for astrometric measurement of stars with different brightness and to classify the stars being observed. The wheel has a clear filter for guide-star acquisition and faint-star (greater than 13 apparent visual magnitude) astrometry. A neutral-density filter is used for observation of nearby bright stars; and two colored filters are utilized for estimating a target's color (chemical) index, increasing contrast between close stars of different colors, or reducing background light from star nebulosity.

4.3.4 Astrometric Observations

Astronomers measure the distance to a star by charting its location on two sightings from Earth at different times, normally 6 months apart. The Earth's orbit changes the perceived (apparent) location of the nearby star, and the parallax angle between the two locations can lead to an estimate of the star's distance. Because stars are so distant, the parallax angle is very small, requiring a precise field of view to calculate the angle. Even with the precision of the FGSs, astronomers cannot measure distances by the parallax method beyond nearby stars in our galaxy.

An important goal of the FGS astrometry project is to obtain improved distances to fundamental distance calibrators in the universe, for instance to the Hyades star cluster. This is one of the foundations of the entire astronomical distance scale. An accurate distance to the Hyades would make it possible for astronomers to infer accurate distances to similar stars that are too distant for the direct parallax method to work.

Astronomers have long suspected that some stars might have a planetary system like that around our Sun. Unfortunately, the great distance of stars and the faintness of any possible planet make it very difficult to detect such systems directly. It may be possible to detect a planet by observing nearby stars and looking for the subtle gravitational effects that a planet would have on the star it is orbiting.

Astronomers use the FGS in two modes of operation to investigate known and suspected binary star systems. Their observations lead to the determination of the orbits and parallaxes of the binary stars and therefore to the masses of these systems. For example, 40 stars in the Hyades cluster were observed with the FGS. Ten of the targets were discovered to be binary star systems and one of them has an orbital period of 3.5 years.

Other objects, such as nearby M dwarf stars with suspected low-mass companions, are being investigated with the FGS with the hope of improving the mass/luminosity relationship at the lower end of the main sequence.

HUBBLE SPACE TELESCOPE SYSTEMS

The Hubble Space Telescope (HST) has three interacting systems:

- The Support Systems Module (SSM), an outer structure that houses the other systems and provides services such as electrical power, data communications, and pointing control and maneuvering
- The Optical Telescope Assembly (OTA), which collects and concentrates the incoming light in the focal plane for use by the science instruments
- Eight major science instruments, four housed in an aft section focal plane structure (FPS) and four placed along the circumference of the spacecraft. With the exception of the Fine Guidance Sensors (FGS), the Science Instrument Control and Data Handling (SI C&DH) unit controls all.

Additional systems that also support HST operations include two Solar Arrays (SA). These generate electrical power and charge onboard batteries and communications antennas to receive commands and send telemetry data from the HST. Figure 5-1 shows the HST configuration.

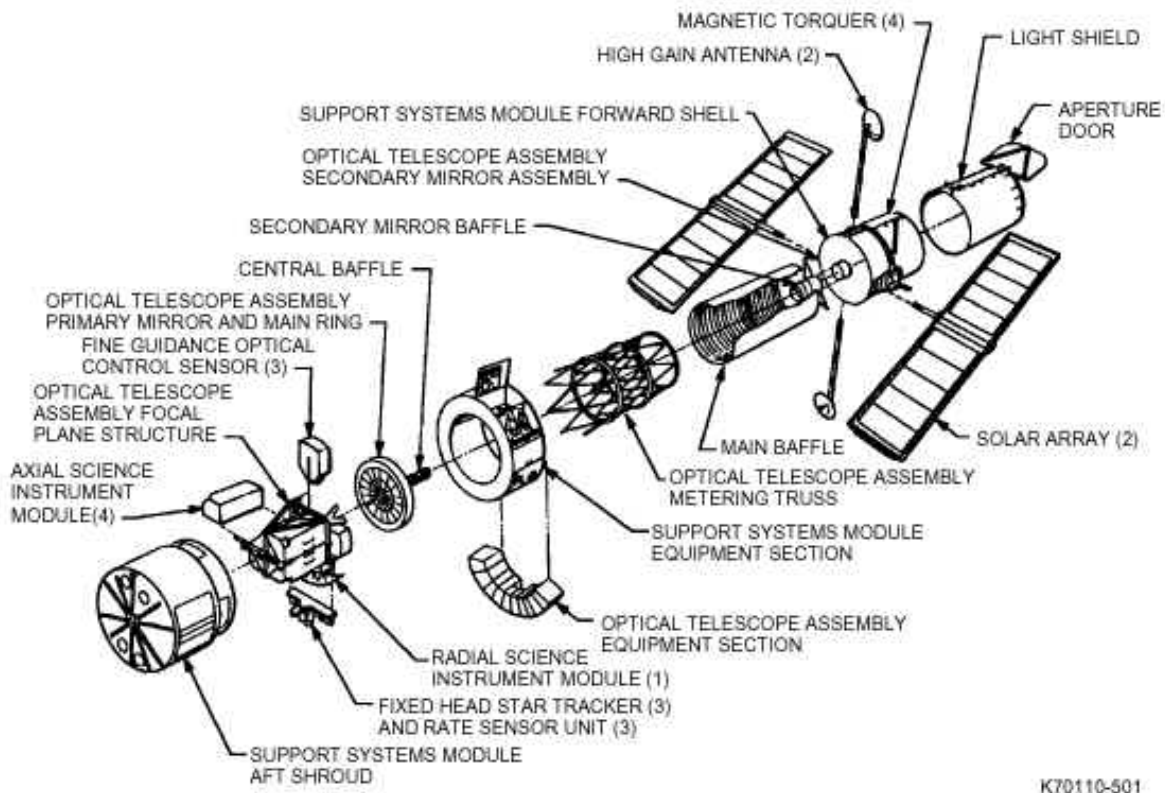

Fig. 5-1 Hubble Space Telescope – exploded view

The Telescope performs much like a ground observatory. The SSM is designed to support functions required by any ground astronomical observatory. It provides power, points the Telescope, and communicates with the OTA, SI C&DH unit, and instruments to ready an observation. Light from an observed target passes through the Telescope and into one or more of the science instruments, where the light is recorded. This information goes to onboard computers for processing, and then it is either temporarily stored or sent to Earth in real time, via the spacecraft communication system.

The Telescope completes one orbit every 97 minutes and maintains its orbital position along three axial planes. The primary axis, V1, runs through the center of the Telescope. The other two axes parallel the SA masts (V2) and the High Gain Antenna (HGA) masts (V3) (see Fig. 5-2). The Telescope points and maneuvers to new targets by rotating about its body axes. Pointing instruments use references to these axes to aim at a target in space, position the SA, or change Telescope

orientation in orbit.

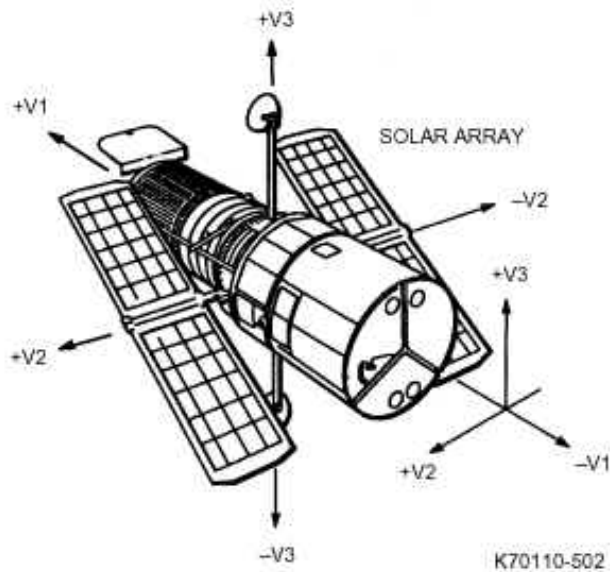

Fig. 5-2 Hubble Space Telescope axes

5.1 Support Systems Module

The design features of the SSM include:

- An outer structure of interlocking shells
- Reaction wheels and magnetic torquers to maneuver, orient, and attitude stabilize the Telescope
- Two SAs to generate electrical power
- Communication antennas
- A ring of Equipment Section bays that contain electronic components, such as batteries, and communications equipment. (Additional bays are provided on the +V3 side of the spacecraft to house OTA electronics as described in para 5.2.4.)
- Computers to operate the spacecraft systems and handle data
- Reflective surfaces and heaters for thermal protection
- Outer doors, latches, handrails, and footholds designed for astronaut use during on-orbit maintenance.

Figure 5-3 shows some of these features. Major component subsystems of the SSM are:

- Structures and mechanisms
- Instrumentation and communications
- Data management
- Pointing control
- Electrical power
- Thermal control
- Safing (contingency) system.

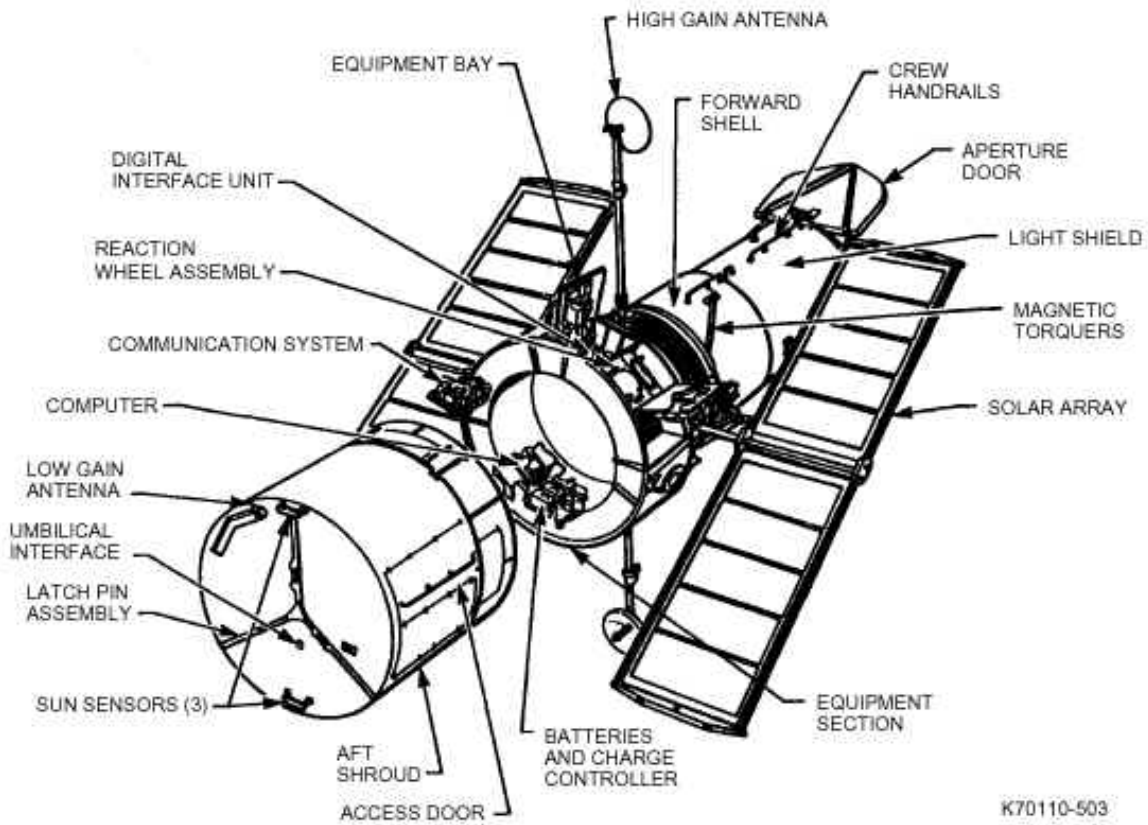

Fig. 5-3 Design features of Support Systems Module

5.1.1 Structures and Mechanisms Subsystem

The outer structure of the SSM consists of stacked cylinders, with the aperture door on top and the aft bulkhead at the bottom. Fitting together are the light shield, the forward shell, the SSM Equipment Section, and the aft shroud/bulkhead – all designed and built by Lockheed Martin Missiles & Space (see Fig. 5-4).

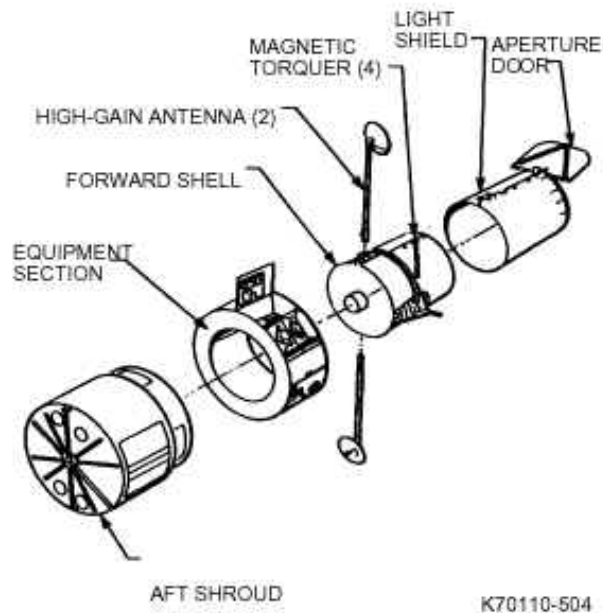

Fig. 5-4 Structural components of Support Systems Module

Aperture Door.

The aperture door, approximately 10-ft (3 m) in diameter, covers the opening to the Telescope's light shield. The door is made from honeycombed aluminum sheets. The outside is covered with solar-reflecting material, and the inside is painted black to absorb stray light.

The door opens a maximum of 105 degrees from the closed position. The Telescope aperture allows for a 50-degree field of view (FOV) centered on the +V1 axis. Sun-avoidance sensors provide ample warning to automatically close the door before sunlight can damage the Telescope's optics. The door begins closing when the sun is within ± 35 degrees of the +V1 axis and is closed by the time the sun reaches 20 degrees of +V1. This takes no more than 60 seconds.

The Space Telescope Operations Control Center (STOCC) can override the protective door-closing mechanism for observations that fall within the 20-degree limit. An example is observing a bright object, using the dark limb (edge) of the Moon to partially block the light.

Light Shield.

The light shield (see Fig. 5-4) blocks out stray light. It connects to both the aperture door and the forward shell. On the outer skin of the Telescope on opposite sides are latches to secure the SAs and HGAs when they are stowed. Near the SA latches are scuff plates, large protective metal plates on struts that extend approximately 30 in. from the surface of the spacecraft. Trunnions lock the Telescope into the Shuttle cargo bay by hooking to latches in the bay. The light shield supports the forward Low Gain Antenna (LGA) and its communications waveguide, two magnetometers, and two sun sensors. Handrails encircle the light shield, and built-in foot restraints support the astronauts working on the Telescope.

Figure 5-5 shows the aperture door and light shield. The shield is 13-ft (4 m) long, with an internal diameter of 10-ft (3 m). It is machined from magnesium, with a stiffened, corrugated-skin barrel covered by a thermal blanket. Internally the shield has 10 light baffles, painted flat black to suppress stray light.

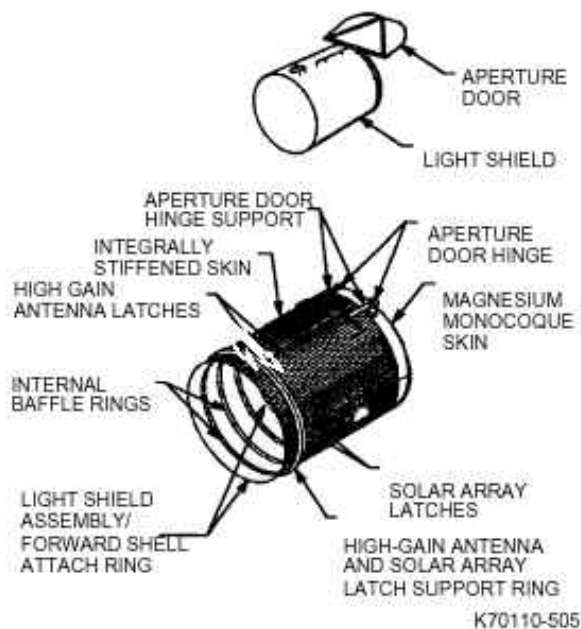

Fig. 5-5 Aperture door and light shield

Forward Shell.

The forward shell, or central section of the structure, houses the OTA main baffle and the secondary mirror (see Fig. 5-6). When stowed, the SAs and HGAs are latched flat against the forward shell and light shield. Four magnetic torquers are placed 90 degrees apart around the circumference of the forward shell. The outer skin has two grapple fixtures next to the HGA drives, where the Shuttle's Remote Manipulator System can attach to the Telescope. The forward shell also has handholds, footholds, and a trunnion, which is used to lock the Telescope into the Shuttle cargo bay.

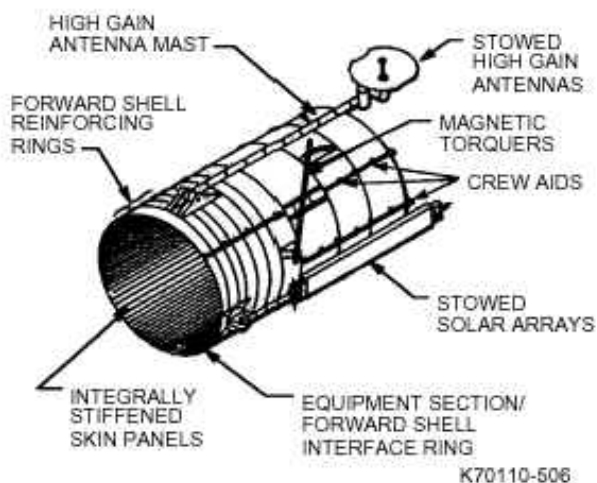

Fig. 5-6 Support Systems Module forward shell

The forward shell is 13-ft (4 m) long and 10-ft (3 m) in diameter. It is machined from aluminum plating, with external reinforcing rings and internal stiffened panels. The rings are on the outside to ensure clearance for the OTA inside. Thermal blankets cover the exterior.

Equipment Section.

This section is a ring of storage bays encircling the SSM. It contains about 90 percent of the electronic components that run the spacecraft, including equipment serviced during extravehicular activities (EVA) by Space Shuttle astronauts.

The Equipment Section is a doughnut-shaped barrel that fits between the forward shell and aft shroud. This section contains 10 bays for equipment and two bays to support aft trunnion pins and scuff plates. As shown in Fig. 5-7, going clockwise from the +V3 (top) position, the bays contain:

1. Bay 8 – pointing control hardware
2. Bay 9 – Reaction Wheel Assembly (RWA)
3. Bay 10 – SI C&DH unit
4. Unnumbered trunnion support bay
5. Bay 1 – data management hardware
6. Bay 2 through Bay 4 – electrical power equipment
7. Unnumbered trunnion support bay
8. Bay 5 – communication hardware
9. Bay 6 – RWA
10. Bay 7 – mechanism control hardware.

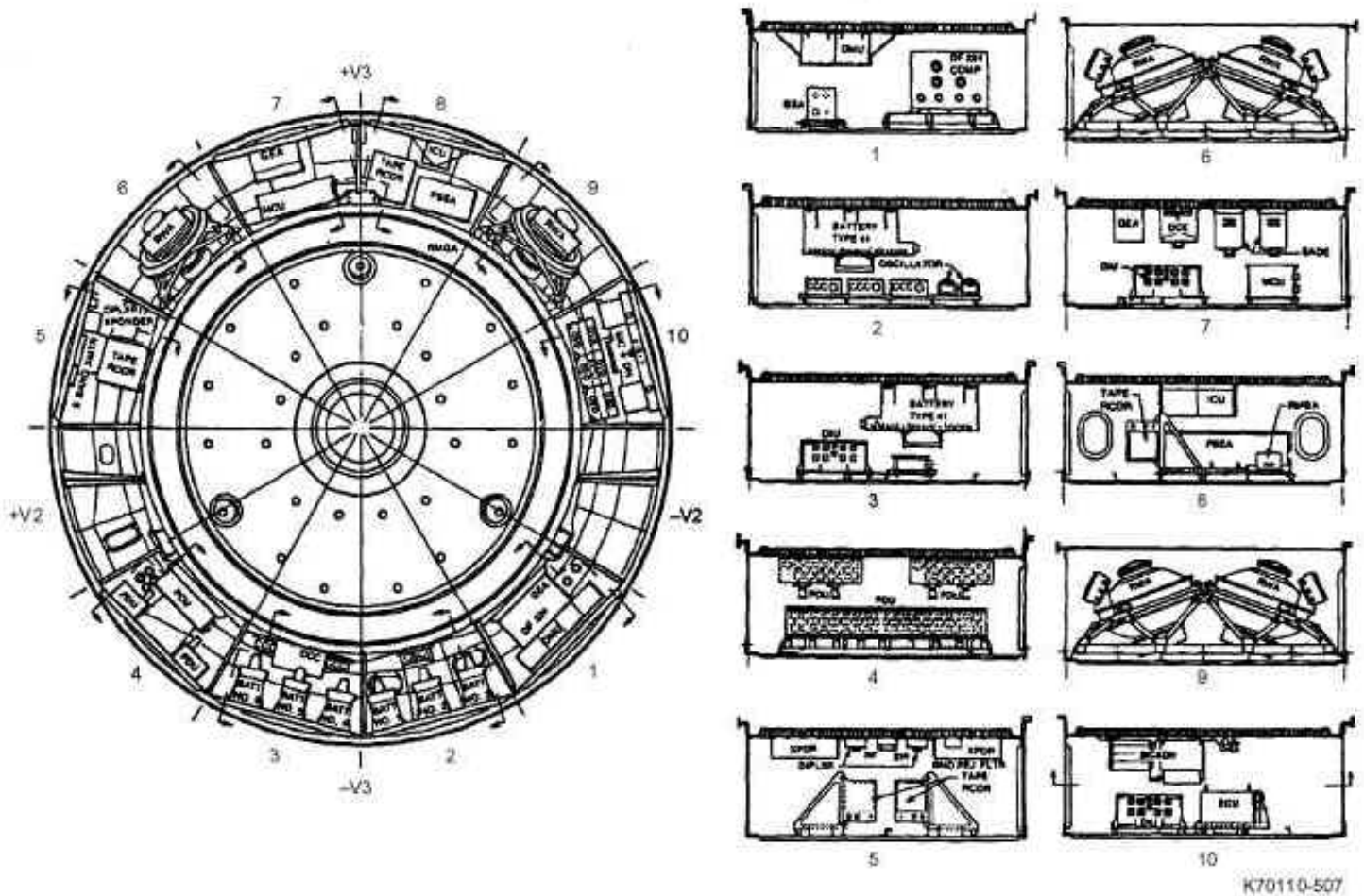

Fig. 5-7. Support Systems Module Equipment Section bays and contents

The cross section of the bays is shaped like a trapezoid, with the outer diameter (the door) – 3.6-ft (1 m) – greater than the inner diameter – 2.6-ft (0.78 m). The bays are 4-ft (1.2 m) wide and 5-ft (1.5 m) deep. The Equipment Section is constructed of machined and stiffened aluminum frame panels attached to an inner aluminum barrel. Eight bays have flat honeycombed aluminum doors mounted with equipment. In Bays 6 and 9, thermal-stiffened panel doors cover the reaction wheels. A

forward frame panel and aft bulkhead enclose the SSM Equipment Section. Six mounts on the inside of the bulkhead hold the OTA.

Aft Shroud and Bulkhead.

The aft shroud (see Fig. 5-8) houses the FPS containing the axial science instruments. It is also the location of the Corrective Optics Space Telescope Axial Replacement (COSTAR) unit.

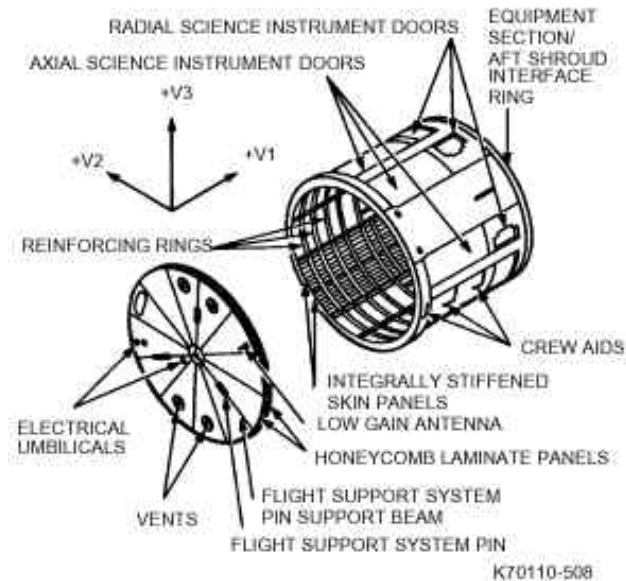

Fig. 5-8 Support Systems Module aft shroud and bulkhead

The three FGSs and the Wide Field and Planetary Camera 2 (WFPC2) are housed radially near the connecting point between the aft shroud and SSM Equipment Section. Doors on the outside of the shroud allow shuttle astronauts to remove and change equipment and instruments easily. Handrails and foot restraints for the crew run along the length and circumference of the shroud. During maintenance or removal of an instrument, interior lights illuminate the compartments containing the science instruments. The shroud is made of aluminum, with a stiffened skin, internal panels and reinforcing rings, and 16 external and internal longeron bars for support. It is 11.5-ft (3.5 m) long and 14-ft (4.3 m) in diameter.

The aft bulkhead contains the umbilical connections between the Telescope and the shuttle, used during launch/deployment and on-orbit maintenance. The rear LGA attaches to the bulkhead, which is made of 2-in.-thick honeycombed aluminum panels and has three radial aluminum support beams.

The shroud and bulkhead support a gas purge system that was used to prevent contamination of the science instruments before launch. All vents used to expel gases are light tight. Thus, stray light is prevented from entering the OTA focal plane.

Mechanisms.

Along the SSM structure are mechanisms that perform various functions, including:

- Latches to hold antennas and SAs
- Hinge drives to open the aperture door and erect arrays and antennas
- Gimbals to move the HGA dishes
- Motors to power the hinges and latches and to rotate arrays and antennas.

There are nine latches: four for antennas, four for arrays, and one for the aperture door. They latch and release using four-bar linkages and are driven by stepper motors called Rotary Drive Actuators (RDA).

There are three hinge drives, one for each HGA and one for the door. The hinges also use an RDA. Both hinges and latches have hex-wrench fittings so an astronaut can manually operate the mechanism to deploy the door, antenna, or array if a motor fails.

5.1.2 Instrumentation and Communications Subsystem

This subsystem provides the communications loop between the Telescope and the Tracking and Data Relay Satellites (TDRS), receiving commands and sending data through the HGAs and LGAs. All information is passed through the Data Management Subsystem (DMS).

The HGAs achieve a much higher RF signal gain, which is required, for example, when transmitting high-data-rate scientific data. These antennas require pointing at the TDRSs because of their characteristically narrow beam widths. On the other hand, the LGAs provide spherical coverage (omnidirectional) but have a much lower signal gain. The LGAs are used for low-rate- data transmission and all commanding of the Telescope.

S-Band Single Access Transmitter (SSAT).

The Telescope is equipped with two SSATs. "S-Band" identifies the frequency at which the science data is transmitted, and "Single Access" specifies the type of antenna on the TDRS satellite to which the data is sent.

High Gain Antennas. Each HGA is a parabolic reflector (dish) mounted on a mast with a two-axis gimbal mechanism and electronics to rotate it 100 degrees in either direction (see Fig. 5-9). General Electric designed and made the antenna dishes. They are manufactured from honeycomb aluminum and graphite-epoxy facesheets.

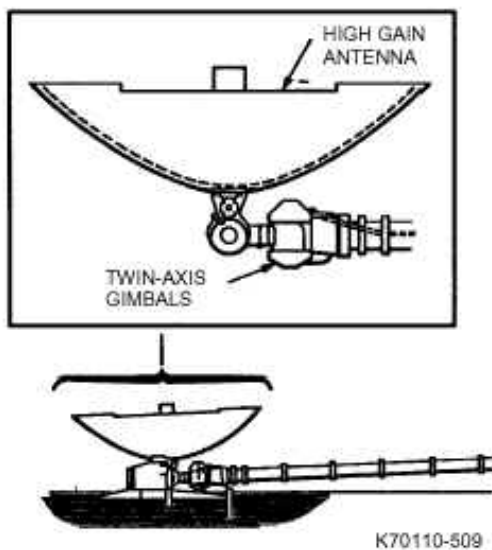

Fig. 5-9 High Gain Antenna

Each antenna can be aimed with a one-degree pointing accuracy. This accuracy is consistent with the overall antenna beam width of over four degrees. The antennas transmit over two frequencies: 2255.5 MHz or 2287.5 MHz (plus or minus 10 MHz).

Low Gain Antennas. The LGAs receive ground commands and transmit engineering data. They are set 180 degrees apart on the light shield and aft bulkhead of the spacecraft. Each antenna is a spiral cone that can operate over a frequency range

from 2100 MHz to 2300 MHz. Manufactured by Lockheed Martin, the LGAs are used for all commanding of the Telescope and for low-data-rate telemetry, particularly during Telescope deployment or retrieval on orbit, or during safemode operations.

5.1.3 Data Management Subsystem

The DMS receives communications commands from the STOCC and data from the SSM systems, OTA, and science instruments. It processes, stores, and sends the information as requested. Subsystem components are:

- DF-224 computer (will be replaced on SM3A with the Advanced Computer)
- Data Management Unit (DMU)
- Four Data Interface Units (DIU)
- Three engineering/science data recorders
- Two oscillators (clocks).

The components are located in the SSM Equipment Section, except for one DIU stored in the OTA Equipment Section. The DMS receives, processes, and transmits five types of signals:

1. Ground commands sent to the HST systems
2. Onboard computer-generated or computer-stored commands
3. Scientific data from the SI C&DH unit
4. Telescope engineering status data for telemetry
5. System outputs, such as clock signals and safemode signals.

Figure 5-10 is the subsystem functional diagram.

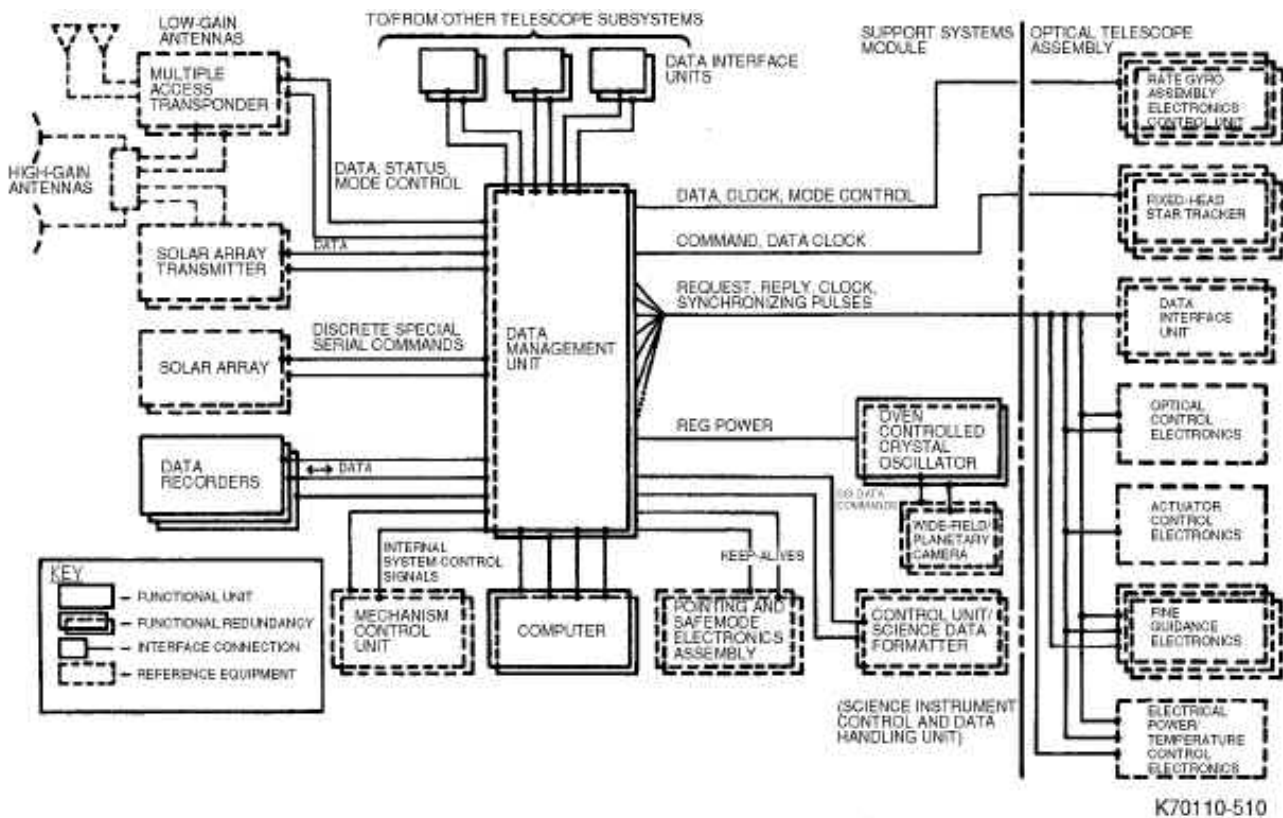

Fig. 5-10 Data Management Subsystem functional block diagram

DF-224 Computer.

The DF-224 computer is a general-purpose digital computer for onboard Fig. 5-10 Data Management Subsystem functional block diagram. It executes stored commands; formats status data (telemetry); performs all Pointing Control Subsystem (PCS) computations to maneuver, point, and attitude stabilize the Telescope; generates onboard commands to orient the SAs toward the Sun; evaluates the health status of the Telescope systems; and commands the HGAs. The Advanced Computer will replace the DF-224 on SM3A and will assume its functions.

Advanced Computer.

The Advanced Computer is based on the Intel 80486 microchip. It operates 20 times faster and has six times as much memory as the DF-224.

The Advanced Computer was designed using commercially developed components. A battery of mechanical, electrical, radiation and thermal tests were performed at GSFC to assure its survival in the space environment. A successful flight test of the hardware was carried out aboard the space shuttle *Discovery* on STS-95 in October 1998.

The Advanced Computer is configured as three independent single-board computers. Each single-board computer (SBC) has two megabytes of fast static random access memory and one megabyte of non-volatile memory.

The Advanced Computer communicates with the HST by using the direct memory access capability on each SBC through the Data Management Unit (DMU). Only one SBC may control the Telescope at a time. The other SBCs can be off, in an idle state, or performing internal tasks.

Upon power on, each SBC runs a built-in self-test and then copies the operating software from slower non-volatile memory to faster random access memory. The self-test is capable of diagnosing any problems with the Advanced Computer and reporting them to the ground. Fast static random access memory is used in the Advanced Computer to eliminate wait states and allow it to run at its full-rated speed.

The Advanced Computer measures 18.8 x 18 x 13 inches (0.48 x 0.46 x 0.33 m) and weighs 70.5 lb (32 kg). It will be located in Bay 1 of the SSM Equipment Section (see Fig. 5-11).

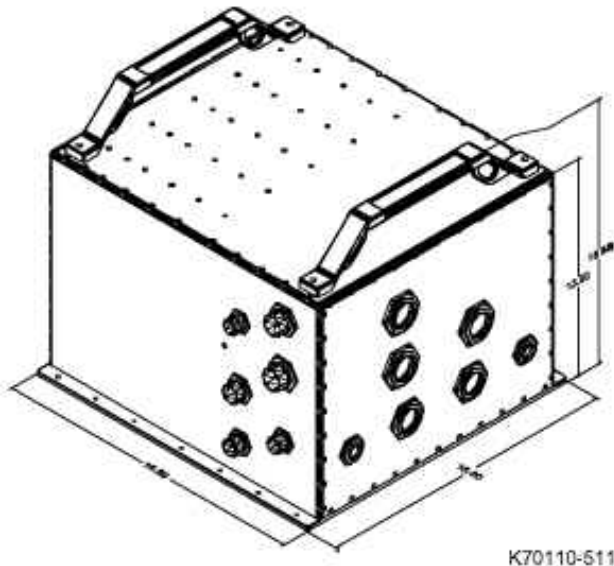

Fig. 5-11 Advanced computer

Data Management Unit.

The DMU links with the computer. It encodes data and sends messages to selected Telescope units and all DMS units, powers the oscillators, and is the central timing source. The DMU also receives and decodes all incoming commands, then transmits each processed command to be executed.

The DMU receives science data from the SI C&DH unit. Engineering data, consisting of sensor and hardware status readings (such as temperature or voltages), comes from each Telescope subsystem. The data can be stored in the onboard data recorders if direct telemetry via a TDRS is unavailable.

The DMU is an assembly of printed-circuit boards, interconnected through a backplate and external connectors. The unit weighs 83 lb (37.7 kg), measures 26 x 30 x 7 in. (60 x 70 x 17 cm), and is attached to the door of Equipment Section Bay 1 (see Fig. 5-12).

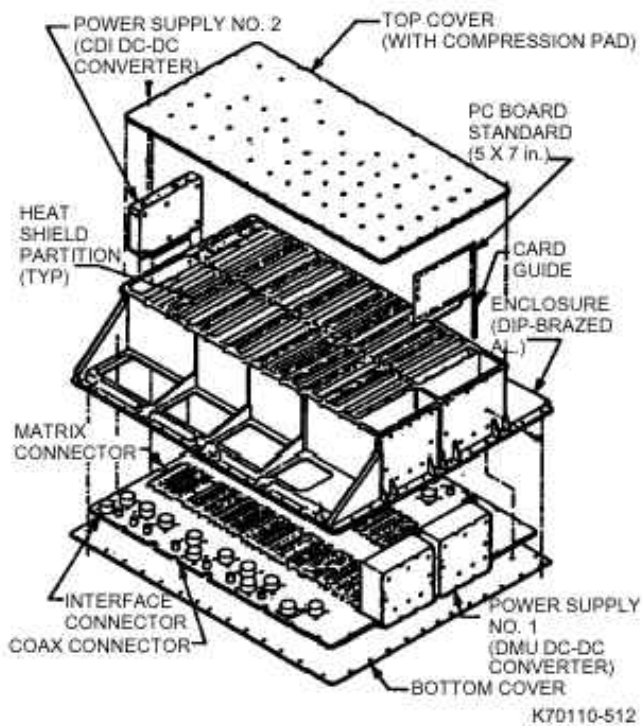

Fig. 5-12 Data Management Unit configuration

Data Interface Unit.

The four DIUs provide a command and data link between DMS and other Telescope electronic boxes. The DIUs receive commands and data requests from the DMU and pass data or status information back to the DMU. The OTA DIU is located in the OTA Equipment Section; the other units are in Bays 3, 7, and 10 of the SSM Equipment Section. As a safeguard, each DIU is two complete units in one; either part can handle the unit's functions. Each DIU measures 15 x 16 x 7 in. (38 x 41 x 18 cm) and weighs 35 lb (16 kg).

Engineering/Science Data Recorders.

The DMS includes three data recorders that store engineering or science data that cannot be transmitted to the ground in real time. The recorders, which are located in Equipment Section Bays 5 and 8, hold up to 12 billion bits of information. Two recorders are used in normal operations; the third is a backup. Each recorder measures 12 x 9 x 7 in. (30 x 23 x 18 cm) and weighs 20 lb (9 kg).

Solid State Recorder.

During SM2 a Solid State Recorder (SSR) was installed, replacing a reel-to-reel tape recorder. A second state-of-the-art SSR will be installed during SM3A. This digital recorder will replace one of the two remaining reel-to-reel recorders on HST. The Solid State Recorders have an expected on-orbit life of at least eight years. They can record two data streams simultaneously, allowing both science and engineering data to be captured on a single recorder. In addition, data can be recorded and played back at the same time.

The SSR has no reels or tape, and no moving parts to wear out and limit lifetime. Data is stored digitally in computer-like memory chips until HST's operators at GSFC command the SSR to play it back. Although they are the same size as the reel-to-reel recorders, the SSRs can store over 10 times more data — 12 gigabits versus only 1.2 gigabits for the tape recorders they replace.

Oscillator.

The oscillator provides a highly stable central timing pulse required by the Telescope. It has a cylindrical housing 4 in. (10 cm) in diameter and 9 in. (23 cm) long and weighs 3 lb (1.4 kg). The oscillator and a backup are mounted in Bay 2 of the SSM Equipment Section.

5.1.4 Pointing Control Subsystem

A unique PCS maintains Telescope pointing stability and aligns the spacecraft to point to and remain locked on any target. The PCS is designed for pointing to within 0.01 arcsec and holding the Telescope in that orientation with 0.007-arcsec stability for up to 24 hours while the Telescope continues to orbit the Earth at 17,500 mph. If the Telescope were in Los Angeles, it could hold a beam of light on a dime in San Francisco without the beam straying from the coin's diameter.

Nominally, the PCS maintains the Telescope's precision attitude by locating guide stars into two FGSs and controlling the Telescope to keep it in the same position relative to these stars. When specific target requests require repositioning the spacecraft, the pointing system selects different reference guide stars and moves the Telescope into a new attitude.

The PCS encompasses the Advanced Computer, various attitude sensors, and two types of devices, called actuators, to move the spacecraft (see Fig. 5-13). It also includes the Pointing/ Safemode Electronics Assembly (PSEA) and the Retrieval Mode Gyro Assembly (RMGA); both used by the spacecraft safemode system. See para 5.1.7 for details.

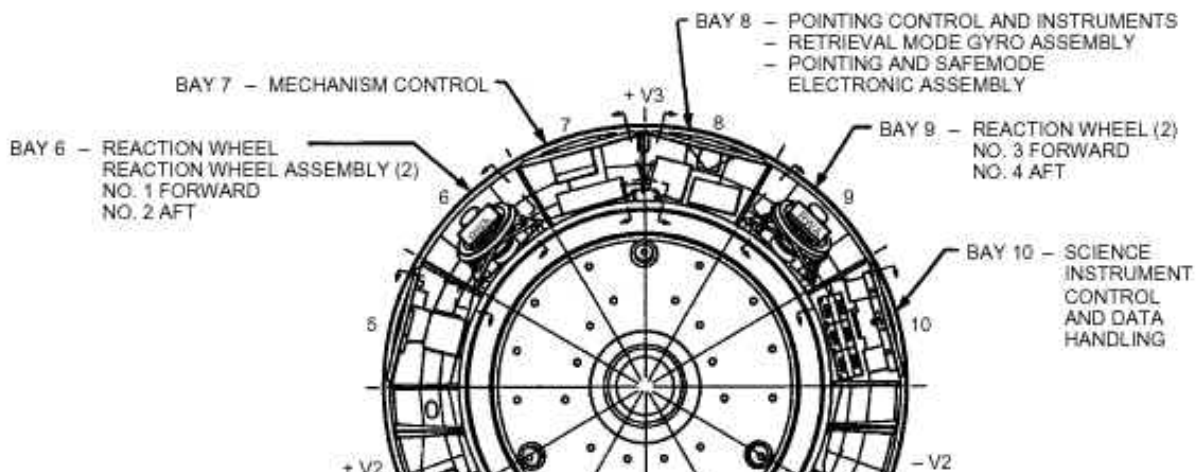
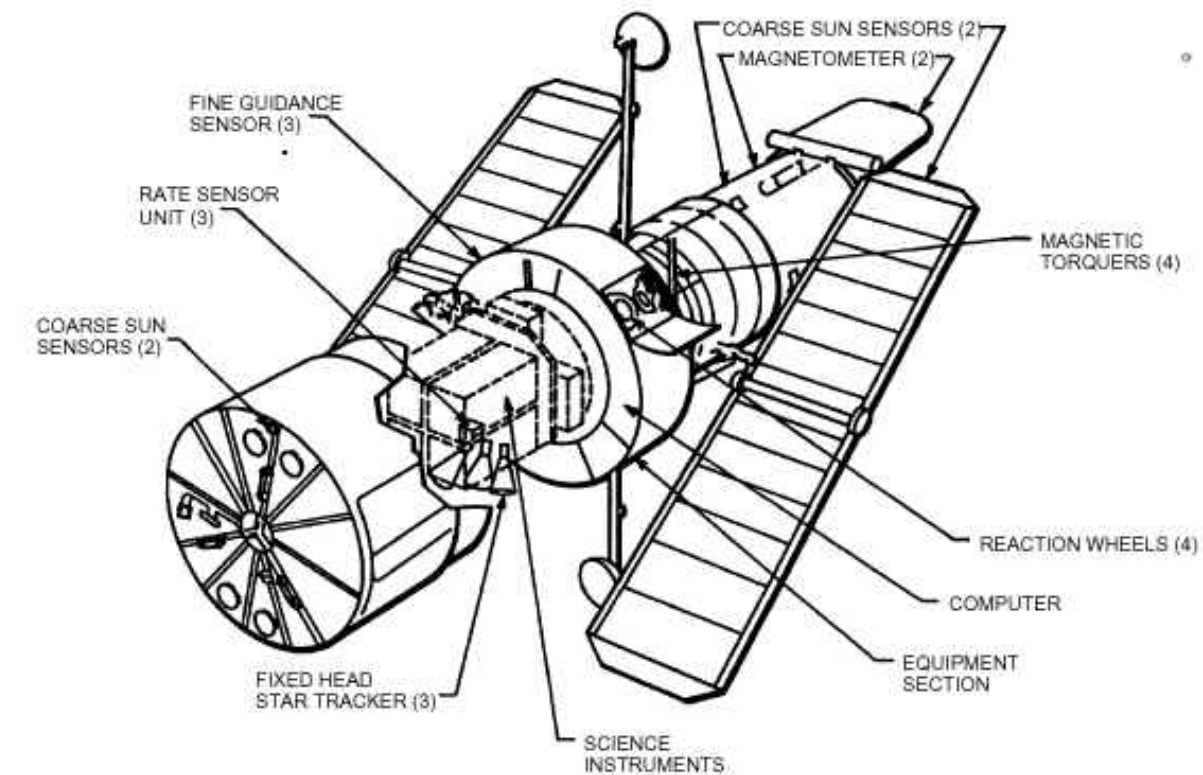

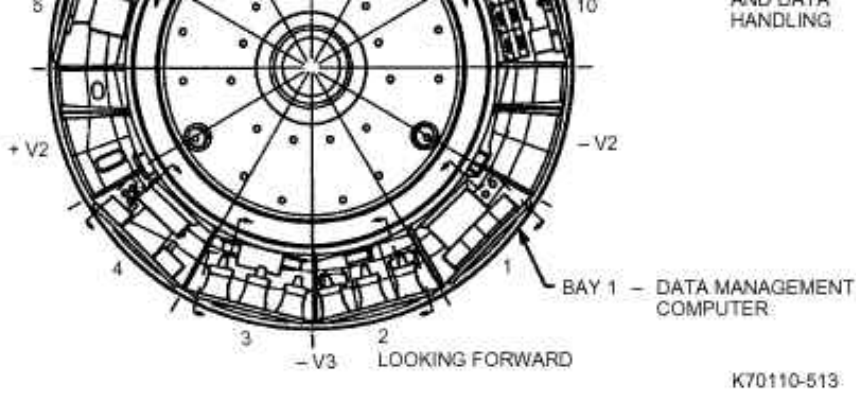

Fig. 5-13 Location of Pointing Control Subsystem equipment

Sensors.

The five types of sensors used by the PCS are the Coarse Sun Sensors (CSS), the Magnetic Sensing System (MSS), the Rate Gyro Assemblies (RGA), the Fixed Head Star Trackers (FHST), and the FGSs.

The CSSs measure the Telescope's orientation to the Sun. They are used to calculate the initial deployment orientation of the Telescope, determine when to begin closing the aperture door, and point the Telescope in special sun-orientation modes during contingency operations. Five CSSs are located on the light shield and aft shroud. CSSs also provide signals to the PSEA, located in Bay 8 of the SSM Equipment Section.

The MSS measures the Telescope's orientation relative to Earth's magnetic field. The system consists of magnetometers and dedicated electronic units that send data to the Advanced Computer and the Safemode Electronic Assembly. Two systems are provided. Both are located on the front end of the light shield.

Three RGAs are provided on the Telescope. Each assembly consists of a Rate Sensor Unit (RSU) and an Electronics Control Unit (ECU). An RSU contains two rate-sensing gyroscopes, each measuring attitude rate motion about its sensitive axis. This output is processed by its dedicated electronics, which are contained in the ECU. Each unit has two sets of electronics. The RSUs are located behind the SSM Equipment Section, next to the FHSTs in the aft shroud. The ECUs are located inside Bay 10 of the SSM Equipment Section. The RGAs provide input to the PCS to control the orientation of the Telescope's line of sight and to provide the attitude reference when maneuvering the Telescope.

Four of the original six rate gyros were replaced during the First Servicing Mission. All six rate gyros are planned for replacement during SM3A. Three of six gyroscopes are required to continue the Telescope science mission.

An FHST is an electro-optical detector that locates and tracks a specific star within its FOV. Three FHSTs are located in the aft shroud behind the FPS, next to the RSUs. STOCC uses star trackers as an attitude calibration device when the Telescope maneuvers into its initial orientation. The trackers also calculate attitude information before and after maneuvers to help the FGS lock onto guide stars.

Three FGSs, discussed in more detail in para 5.3, provide angular position with respect to the stars. Their precise fine-pointing adjustments, accurate to within a fraction of an arcsecond, pinpoint the guide stars. Two of the FGSs perform guide-star pointing, while the third is available for astrometry, the positional measurement of specific stars.

Pointing Control Subsystem Software.

PCS software accounts for a large percentage of the flight code executed by the Hubble's main computer. This software translates ground targeting commands into reaction wheel torque profiles that reorient the spacecraft. All motion of the spacecraft is smoothed to minimize jitter during data collection. The software also determines Telescope orientation, or attitude, from FHST or FGS data and commands the magnetic torquer bars so that reaction wheel speeds are always minimized. In addition, the software provides various telemetry formats.

Since the Telescope was launched, major modifications have been made to the PCS. A digital filtering scheme, known as Solar Array Gain Augmentation (SAGA) was incorporated to mitigate the effect of any SA vibration or jitter on pointing stability. Software also was used to improve FGS performance when the Telescope is subjected to the same disturbances. This algorithm is referred to as the FGS Re-Centering Algorithm.

Software is used extensively to increase Telescope robustness when hardware failures are experienced. Two additional software safemodes have been provided. The spin-stabilized mode provides pointing of the Telescope -V1 axis to the Sun with only two of the four RWAs operating. The other mode allows Sun pointing of the Telescope without any input from the RGA; magnetometer and CSS data is used to derive all reference information needed to maintain Sun pointing (+V3 and -V1 are options).

A further software change "refreshes" the FGS configuration. This is achieved by maintaining data in the Advanced Computer memory so it can be sent periodically to the FGS electronics, which are subject to single-event upsets (logic state change) when transitioning through the South Atlantic Anomaly.

Actuators.

The PCS has two types of actuators: RWAs and magnetic torquers. Actuators move the spacecraft into commanded attitudes and provide required control torques to stabilize the Telescope's line of sight.

The reaction wheels work by rotating a large flywheel up to 3000 rpm or braking it to exchange momentum with the spacecraft. The wheel axes are oriented so that the Telescope can provide science with only three wheels operating. Wheel assemblies are paired, two each in Bays 6 and 9 of the SSM Equipment Section. Each wheel is 23 in. (59 cm) in diameter and weighs about 100 lb (45 kg). Figure 5-14 shows the RWA configuration.

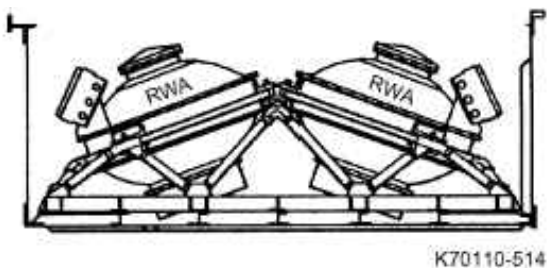

Fig. 5-14 Reaction Wheel Assembly

Magnetic torquers create torque on the spacecraft and are primarily used to manage reaction wheel speed. The torquers react against Earth's magnetic field. The torque reaction occurs in the direction that reduces the reaction wheel speed, managing the angular momentum.

The magnetic torquers also provide backup control to stabilize the Telescope's orbital attitude during the contingency modes, as described in para 5.1.2. Each torquer, located externally on the forward shell of the SSM, is 8.3 ft (2.5 m) long and 3 in. (8 cm) in circumference and weighs 100 lb (45 kg).

Pointing Control Operation.

To point precisely, the PCS uses the gyroscopes, reaction wheels, magnetic torquers, star trackers, and FGSs. The FGSs provide the precision reference point from which the Telescope can begin repositioning. Flight software commands the reaction wheels to spin, accelerating or decelerating as required to rotate the Telescope toward a new target. Rate gyroscopes sense the Telescope's angular motion and provide a short-term attitude reference to assist fine pointing and spacecraft maneuvers. The magnetic torquers reduce reaction wheel speed.

As the Telescope nears the target area, star trackers locate preselected reference stars that stand out brightly in that region of

the sky. Once the star trackers reduce the attitude error below 60 arcsec, the two FGSs take over the pointing duties. Working with the gyroscopes, the FGSs make possible pointing the Telescope to within 0.01 arcsec of the target. The PCS can maintain this position, wavering no more than 0.005 arcsec, for up to 24 hours to guarantee faint-object observation.

5.1.5 Electrical Power Subsystem

Power for the Telescope and science instruments comes from the Electrical Power Subsystem (EPS). The major components are two SA wings and their electronics, six batteries, six Charge Current Controllers (CCC), one Power Control Unit (PCU), and four Power Distribution Units (PDU). All except the SAs are located in the bays around the SSM Equipment Section.

During the servicing mission, the Shuttle will provide the electrical power. After deployment, the SAs again begin converting solar radiation into electricity. Energy will be stored in nickel-hydrogen (NiH₂) batteries and distributed by the PCUs and PDUs to all Telescope components as shown in Fig. 5-15. The Telescope will not be released until the batteries are fully charged.

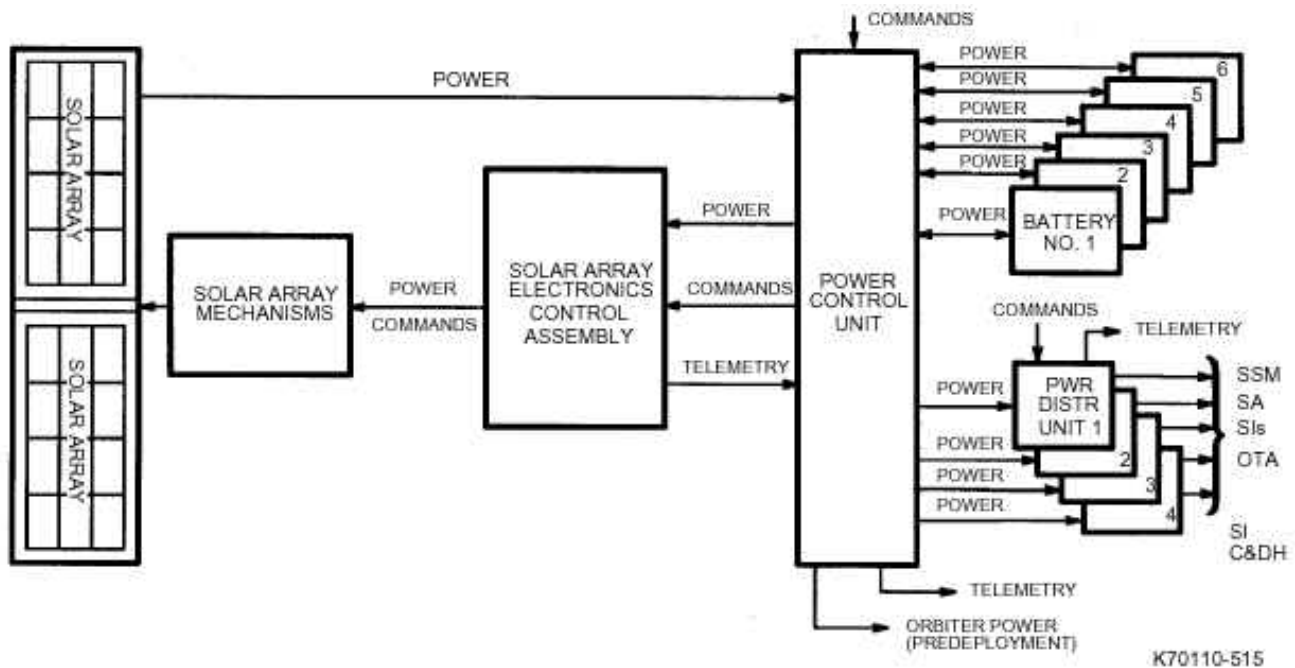

Fig. 5-15 Electrical Power Subsystem functional block diagram

Solar Arrays.

The SA panels, discussed later in this section, are the primary source of electrical power. Each array wing has a solar cell blanket that converts solar energy into electrical energy. Electricity produced by the solar cells charges the Telescope batteries.

Each array wing has associated electronics. These consist of a Solar Array Drive Electronics (SADE) unit, which transmits positioning commands to the wing assembly; a Deployment Control Electronics Unit, which controls the drive motors extending and retracting the wings; and diode networks to direct the electrical current flow.

Batteries and Charge Current Controllers.

Developed for the 1990 deployment mission, the Telescope's batteries were NASA's first flight NiH₂ batteries. They provide the observatory with a robust, long-life electrical energy storage system.

Six NiH₂ batteries support the Telescope's electrical power needs during three periods: when demand exceeds SA capability, when the Telescope is in Earth's shadow, and during safemode entry. The batteries reside in SSM Equipment

Section Bays 2 and 3. These units have extensive safety and handling provisions to protect the Shuttle and its astronauts. The design and operation of these batteries, along with special nondestructive inspection of each cell, have allowed these units to be "astronautated" for replacement during a servicing mission. To compensate for the effects of battery aging, SM3A astronauts will install a Voltage/Temperature Improvement Kit (VIK) on each of Hubble's six batteries. The VIK provides battery thermal stability by precluding battery overcharge when the HST enters safemode, effectively lowering the Charge Current Controller (CCC) recharge current.

Each battery consists of 22 cells in series along with heaters, heater controllers, pressure measurement transducers and electronics, and temperature-measuring devices and their associated electronics. Three batteries are packaged into a module measuring roughly 36 by 36 by 10 in. (90 x 90 x 25 cm) and weighing about 475 lb (214 kg). Each module is equipped with two large yellow handles that astronauts use to maneuver the module in and out of the Telescope in space.

The SAs recharge the batteries every orbit following eclipse (the time in the Earth's shadow). The recharge current is controlled by the CCCs. Each battery has its own CCC that uses voltage-temperature measurements to control battery recharge.

Fully charged, each battery contains more than 75 amp-hours. This is sufficient energy to sustain the Telescope in normal science operations mode for 7.5 hours or five orbits. The batteries provide an adequate energy reserve for all possible safemode contingencies and all enhancements programmed into the Telescope since launch.

Power Control and Distribution Units.

The PCU interconnects and switches current flowing among the SAs, batteries, and CCCs. Located in Bay 4 of the Equipment Section, the PCU provides the main power bus to the four PDUs. The PCU weighs 120 lb (55 kg) and measures 43 x 12 x 8 in. (109 x 30 x 20 cm).

Four PDUs, located on the inside of the door to Bay 4, contain the power buses, switches, fuses, and monitoring devices for electrical power distribution to the rest of the Telescope. Two buses are dedicated to the OTA, science instruments, and SI C&DH; two supply the SSM. Each PDU measures 10 x 5 x 18 in. (25 x 12.5 x 45 cm) and weighs 25 lb (11 kg).

5.1.6 Thermal Control

Multilayer insulation (MLI) covers 80 percent of the Telescope's exterior, and supplemental electric heaters maintain its temperatures within safe limits. The insulation blankets are 15 layers of aluminized Kapton, with an outer layer of aluminized Teflon flexible optical solar reflector (FOSR). Aluminized or silvered flexible reflector tape covers most of the remaining exterior. These coverings protect against the cold of space and reflect solar heat. In addition, reflective or absorptive paints are used.

The SSM Thermal Control Subsystem (TCS) maintains temperatures within set limits for the components mounted in the Equipment Section and structures interfacing with the OTA and science instruments. The TCS maintains safe component temperatures even for worst-case conditions such as environmental fluctuations, passage from "cold" Earth shadow to "hot" solar exposure during each orbit, and heat generated from equipment operation.

Specific thermal-protection features of the SSM include:

- MLI thermal blankets for the light shield and forward shell
- Aluminum FOSR tape on the aperture door surface facing the sun
- Specific patterns of FOSR and MLI blankets on the exteriors of the Equipment Section bay doors, with internal MLI blankets on the bulkheads to maintain thermal balance between bays
- Efficient placement of equipment and use of equipment bay space to match temperature requirements, such as placing heat-

dissipating equipment on the side of the Equipment Section mostly exposed to orbit shadow

- Silvered FOSR tape on the aft shroud and aft bulkhead exteriors
- Radiation shields inside the aft shroud doors and MLI blankets on the aft bulkhead and shroud interiors to protect the science instruments
- More than 200 temperature sensors and thermistors placed throughout the SSM, externally and internally, to monitor individual components and control heater operations.

Figure 5-16 shows the location and type of thermal protection used on the SSM. SM2 observations identified degradations of all of the MLI. Additional material will be installed during SM3A to cover some of the degraded material and restore the external layer surface properties. The additional material has been life-tested to an equivalent of 10 years.

The layer being added to the SSM Equipment Section is a composite-coated (silicone dioxide) stainless steel layer, known as the New Outer Blanket Layer (NOBL). The light shield/ forward shell material is Teflon with a scrim backing for durability.

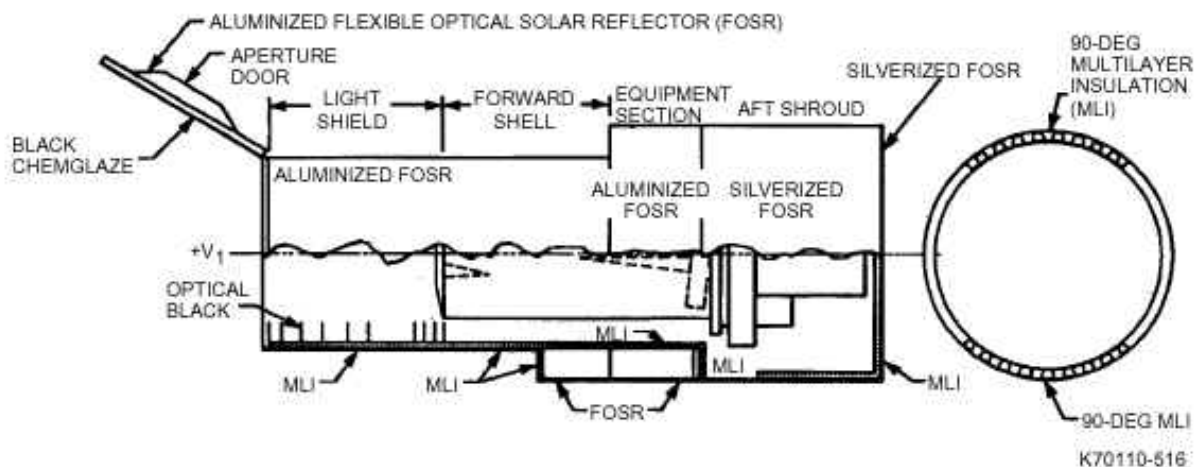

Fig. 5-16 Placement of thermal protection on Support Systems Module

5.1.7 Safing (Contingency) System

Overlapping or redundant Telescope equipment safeguards against any breakdown. Nonetheless, a contingency or Safing System exists for emergency operations. It uses many pointing control and data management components as well as dedicated PSEA hardware. This system maintains stable Telescope attitude, moves the SAs for maximum Sun exposure, and conserves electrical power by minimizing power drain. The Safing System can operate the spacecraft indefinitely with no communications link to ground control.

During scientific observations (normal mode), the Safing System is relegated to monitor automatically Telescope onboard functions. The system sends Advanced-Computer-generated "keep-alive" signals to the PSEA that indicate all Telescope systems are functioning. Entry into the Safemode is autonomous once a failure is detected.

The Safing System is designed to follow a progression of contingency operating modes, depending on the situation aboard the Telescope. If a malfunction occurs and does not threaten the Telescope's survival, the Safing System moves into a Software Inertial Hold Mode. This mode holds the Telescope in the last position commanded. If a maneuver is in progress, the Safing System completes the maneuver, then holds the Telescope in that position, suspending all science operations. Only ground control can return to science operations from Safemode.

If the system detects a marginal electrical power problem, or if an internal PCS safety check fails, the Telescope enters the Software Sun Point Mode. The Safing System maneuvers the Telescope so the SAs point toward the Sun to continuously generate solar power. Telescope equipment is maintained within operating temperatures and above survival temperatures, anticipating a return to normal operations. The STOCC must intercede to correct the malfunction before any science operations or normal functions can be resumed.

Since deployment of the Telescope in 1990, the Safing System has seen additional improvements to increase its robustness to survive hardware failures and still protect the Telescope. Paragraph 5.1.4 describes these features.

For the modes described above, the Safing System operates through computer software. If conditions worsen, the system turns over control to the PSEA in Hardware Sun Point Mode. Problems that could provoke this action include any of the following:

- Computer malfunction
- Batteries losing more than 50 percent of their charge
- Two of the three RGAs failing
- DMS failing.

If these conditions occur, the Advanced Computer stops sending keep-alive signals. This is the "handshake" mechanism between the flight software and the PSEA.

In the Hardware Sun Point Mode, the PSEA computer commands the Telescope and turns off selected equipment to conserve power. Components shut down include the Advanced Computer and, within two hours, the SI C&DH. Before this, a payload (instruments) safing sequence begins and, if it has not already done so, the Telescope turns the SAs toward the Sun, guided by the CSSs. The PSEA removes operating power from equipment not required for Telescope survival.

Once ground control is alerted to a problem, NASA management of the STOCC convenes a failure analysis team to evaluate the problem and seek the best and safest corrective action while the Safing System maintains control of the Telescope.

The failure analysis team is led by a senior management representative from NASA/GSFC with the authority not only to call upon the expertise of engineers and scientists employed by NASA or its support contractors, but also to draft support from any organization previously affiliated with the Telescope Project. The failure analysis team is chartered to identify the nature of the anomaly and to recommend corrective action. This recommendation is reviewed at a higher management level of NASA/GSFC. All changes to the Telescope's hardware and all software configurations require NASA Level I concurrence as specified in the HST Level I Operations Requirements Document.

Pointing/Safemode Electronics and Retrieval Mode Gyro Assemblies.

The PSEA consists of 40 electronic printed-board circuits with redundant functions to run the Telescope, even in the case of internal circuit failure. It weighs 86 lb (39 kg) and is installed in the Equipment Section Bay 8. A backup gyroscope package, the RMGA, is dedicated for the PSEA and is also located in Bay 8. The RMGA consists of three gyroscopes. These are lower quality rate sensors than the RGAs because they are not intended for use during observations.

5.2 Optical Telescope Assembly

The OTA was designed and built by the Perkin-Elmer Corporation (Raytheon Optical Systems, Inc.). Although the OTA is modest in size by ground-based observatory standards and has a straightforward optical design, its accuracy – coupled with its place above the Earth's atmosphere – renders its performance superior.

The OTA uses a "folded" design, common to large telescopes, which enables a long focal length of 189 ft (57.6 m) to be packaged into a small telescope length of 21 ft (6.4 m). (Several smaller mirrors in the science instruments are designed similarly to lengthen the light path within the particular science instrument.) This form of telescope is called a Cassegrain, and its compactness is an essential component of an observatory designed to fit inside the Shuttle cargo bay.

Conventional in design, the OTA is unconventional in other aspects. Large telescopes at ground-based sites are limited in their performance by the resolution attainable while operating under the Earth's atmosphere, but the HST orbits high above the atmosphere and provides an unobstructed view of the universe. For this reason the OTA was designed and built with exacting tolerances to provide near-perfect image quality over the broadest possible region of the spectrum.

The OTA is a variant of the Cassegrain, called a Ritchey-Chretien, in which both the mirrors are hyperboloidal in shape (having a deeper curvature than a parabolic mirror). This form is completely corrected for coma (an image observation having a "tail") and spherical aberrations to provide an aplanatic system in which aberrations are correct everywhere in the FOV. The only residual aberrations are field curvature and astigmatism. Both of these are zero exactly in the center of the field and increase toward the edge of the field. These aberrations are easily corrected within the instrument optics. For example, in the Faint Object Camera (FOC) there is a small telescope designed to remove image astigmatism.

Figure 5-17 shows the path of a light ray from a distant star as it travels through the Telescope to the focus. Light travels down the tube, past baffles that attenuate reflected light from unwanted bright sources, to the 94.5-in. (2.4-m) primary mirror. Reflecting off the front surface of the concave mirror, the light bounces back up the tube to the 12-in. (0.3-m)-diameter convex secondary mirror. The light is now reflected and converged through a 23.5-in. (60-cm) hole in the primary mirror to the Telescope focus, 3.3 ft (1.5 m) behind the primary mirror.

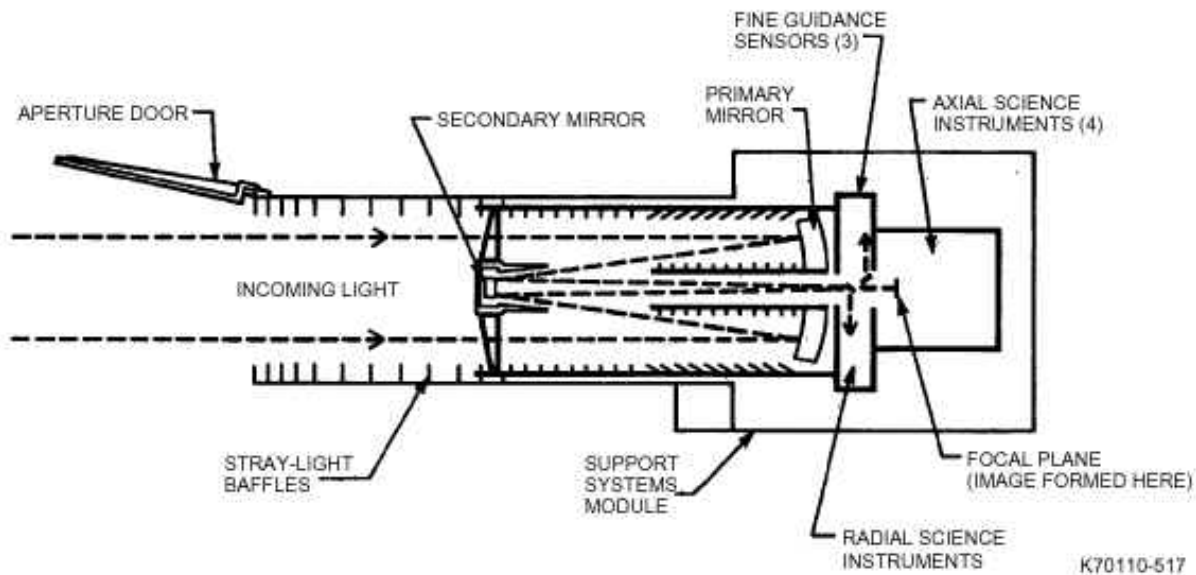

Fig. 5-17 Light path for the main Telescope

Four science instruments and three FGSs share the focal plane by a system of mirrors. A small "folding" mirror in the center of the FOV directs light into the WFPC2. The remaining "science" field is divided among three axial science instruments, each receiving a quadrant of the circular FOV. Around the outside of the science field, a "guidance" field is divided among the three FGSs by their own folding mirrors. Each FGS receives 60 arcmin² of field in a 90-degree sector. Figure 5-18 shows instrument/sensor fields of view.

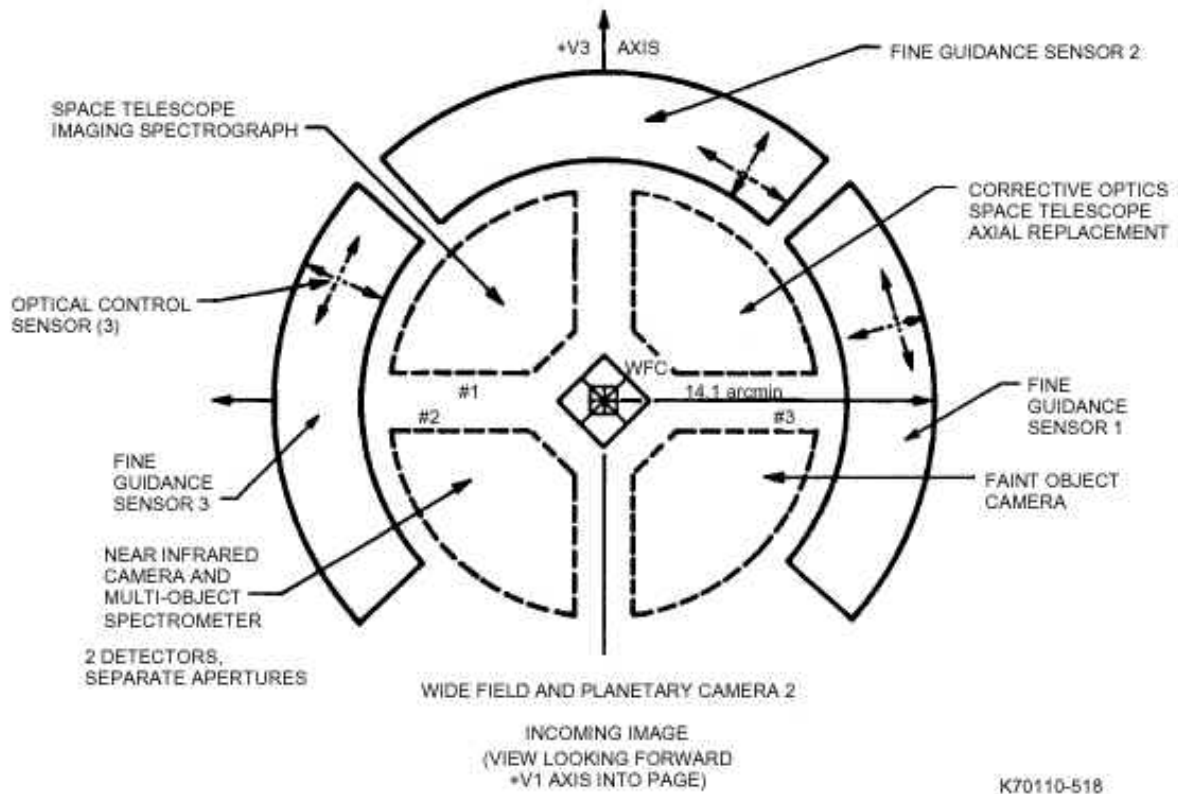
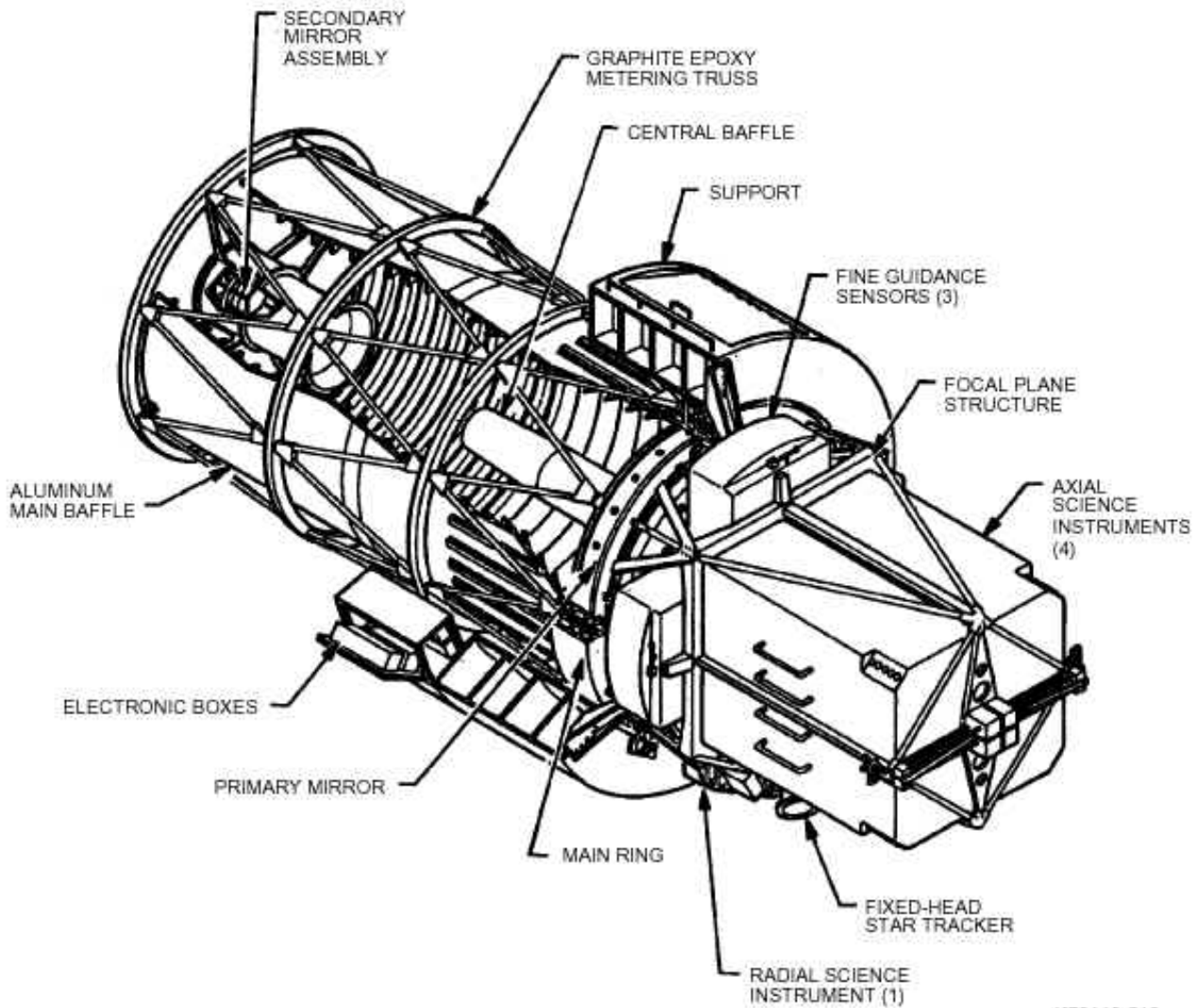

Fig. 5-18 Instrument/sensor field of view

The OTA hosts the science instruments and FGSs in that it maintains the structural support and optical-image stability required for these instruments to fulfill their functions (see Fig. 5-19). Components of the OTA are the primary mirror, the secondary mirror, the FPS, and the OTA Equipment Section. Perkin-Elmer Corporation designed and built all the optical assemblies; Lockheed Martin built the OTA equipment section.



K70110-519

Fig. 5-19 Optical Telescope Assembly components

5.2.1 Primary Mirror Assembly and Spherical Aberration

As the Telescope was put through its paces on orbit in 1990, scientists discovered its primary mirror had a spherical aberration. The outer edge of the 8-foot (2.4-m) primary mirror was ground too flat by a width equal to 1/50 the thickness of a sheet of paper (about 2 microns). After intensive investigation, the problem was traced to faulty test equipment used to define and measure mirror curvature. The optical component of this test equipment was slightly out of focus and, as a result, had shown the mirror to be ground correctly. After the discovery, Ball Aerospace scientists and engineers built the Corrective Optics Space Telescope Axial Replacement (COSTAR). The COSTAR was installed during the First Servicing Mission in December 1993 and brought the Telescope back to its original specifications.

The primary mirror assembly consists of the mirror supported inside the main ring, which is the structural backbone of the Telescope, and the main and central baffles shown in Fig. 5-20. This assembly provides the structural coupling to the rest of the spacecraft through a set of kinematic brackets linking the main ring to the SSM. The assembly also supports the OTA baffles. Its major parts are:

- Primary mirror
- Main ring structure
- Reaction plate and actuators

- Main and central baffles.

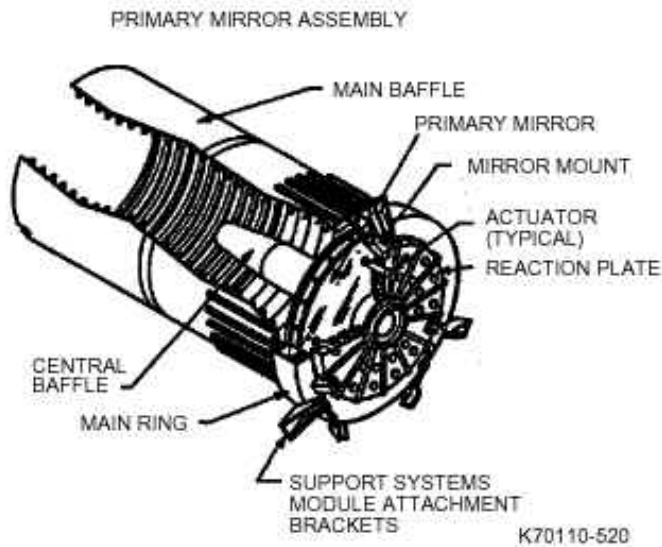

Fig. 5-20 Primary mirror assembly

Primary Mirror.

The primary mirror blank, a product of Corning Glass Works, is known as ultralow-expansion (ULE) glass. It was chosen for its very low-expansion coefficient, which ensures the Telescope minimum sensitivity to temperature changes. The mirror is of a "sandwich" construction: two lightweight facesheets separated by a core, or filling, of glass honeycomb ribs in a rectangular grid (see Fig. 5-21). This construction results in an 1800-lb (818-kg) mirror instead of an 8000-lb solid-glass mirror.

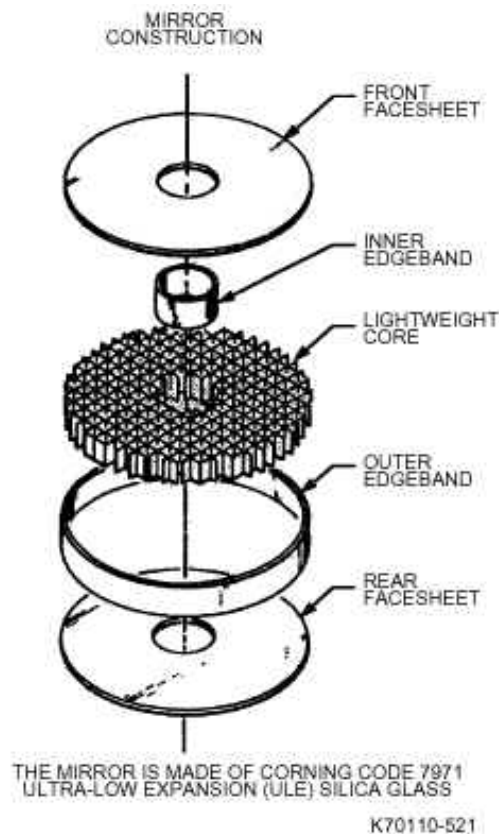

Fig. 5-21 Primary mirror construction

Perkin-Elmer (now Raytheon Optical Systems, Inc.) ground the mirror blank, 8 ft (2.4 m) in diameter, to shape in its large optics fabrication facility. When it was close to its final hyperboloidal shape, the mirror was transferred to Perkin-Elmer's computer-controlled polishing facility. After being ground and polished, the mirror was coated with a reflective layer of aluminum and a protective layer of magnesium fluoride only 0.1 and 0.025 micrometer thick, respectively. The fluoride layer protects the aluminum from oxidation and enhances reflectance at the important hydrogen emission line known as Lyman-Alpha. The reflective quality of the mirror is better than 70 percent at 1216 angstroms (Lyman-Alpha) in the ultraviolet spectral range and better than 85 percent for visible light.

The primary mirror is mounted to the main ring through a set of kinematic linkages. The linkages attach to the mirror by three rods that penetrate the glass for axial constraint and by three pads bonded to the back of the glass for lateral support.

Main Ring.

The main ring encircles the primary mirror; supports the mirror, the main baffle and central baffle, and the metering truss; and integrates the elements of the Telescope to the spacecraft. The titanium ring is a hollow box beam 15 in. (38 cm) thick, weighing 1200 lb (545.5 kg), with an outside diameter of 9.8 ft (2.9 m) (see Fig. 5-22). It is suspended inside the SSM by a kinematic support.

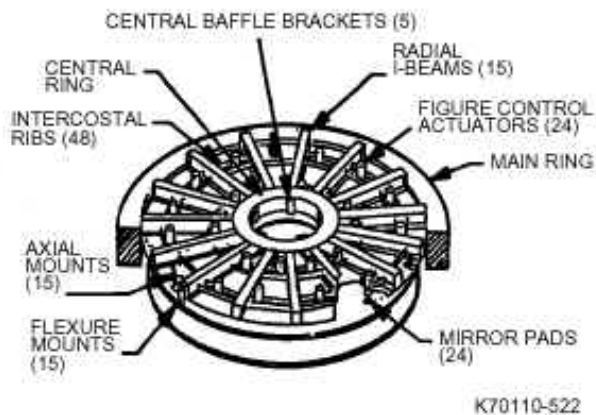

Fig. 5-22 Main ring and reaction plate

Reaction Plate. The reaction plate is a wheel of I-beams forming a bulkhead behind the main ring, spanning its diameter. It radiates from a central ring that supports the central baffle. Its primary function is to carry an array of heaters that warm the back of the primary mirror, maintaining its temperature at 70 degrees. Made of lightweight, stiff beryllium, the plate also supports 24 figure-control actuators attached to the primary mirror and arranged around the reaction plate in two concentric circles. These can be commanded from the ground, if necessary, to make small corrections to the shape of the mirror.

Baffles. The baffles of the OTA prevent stray light from bright objects, such as the Sun, Moon, and Earth, from reflecting down the Telescope tube to the focal plane. The primary mirror assembly includes two of the three assembly baffles.

Attached to the front face of the main ring, the outer, main baffle is an aluminum cylinder 9 ft (2.7 m) in diameter and 15.7 ft (4.8 m) long. Internal fins help it attenuate stray light. The central baffle is 10 ft (3 m) long, conical in shape, and attached to the reaction plate through a hole in the center of the primary mirror. It extends down the centerline of the Telescope tube. The baffle interiors are painted flat black to minimize light reflection.

5.2.2 Secondary Mirror Assembly

The Secondary Mirror Assembly cantilevers off the front face of the main ring and supports the secondary mirror at exactly the correct position in front of the primary mirror. This position must be accurate within 1/10,000 in. whenever the

Telescope is operating. The assembly consists of the mirror subassembly, a light baffle, and an outer graphite-epoxy metering truss support structure (see Fig. 5-23).

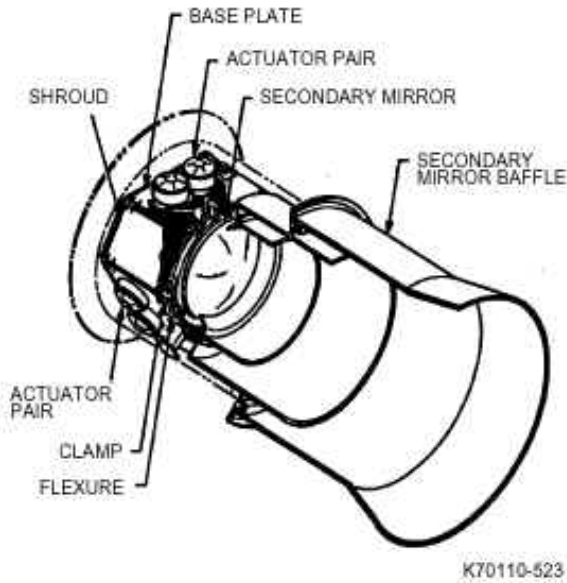

Fig. 5-23 Secondary mirror assembly

The Secondary Mirror Assembly contains the mirror, mounted on three pairs of alignment actuators that control its position and orientation. All are enclosed within the central hub at the forward end of the truss support.

The secondary mirror has a magnification of 10.4X, converting the primary-mirror converging rays from $f/2.35$ to a focal ratio system prime focus of $f/24$ and sending them back toward the center of the primary mirror, where they pass through the central baffle to the focal point. The mirror is a convex hyperboloid 12 in. (0.3 m) in diameter and made of Zerodur glass coated with aluminum and magnesium fluoride. Steeply convex, its surface accuracy is even greater than that of the primary mirror.

Ground command adjusts the actuators to align the secondary mirror to provide perfect image quality. The adjustments are calculated from data picked up by tiny optical control system sensors located in the FGSs.

The principal structural element of the Secondary Mirror Assembly is the metering truss, a cage with 48 latticed struts attached to three rings and a central support structure for the secondary mirror. The truss, 16 ft (4.8 m) long and 9 ft (2.7 m) in diameter, is a graphite, fiber-reinforced epoxy structure. Graphite was chosen for its high stiffness, light weight, and ability to reduce the structure's expansiveness to nearly zero. This is vital because the secondary mirror must stay perfectly placed relative to the primary mirror, accurate to within 0.0001 in. (2.5 micrometers) when the Telescope operates.

The truss attaches at one end to the front face of the main ring of the Primary Mirror Assembly. The other end has a central hub that houses the secondary mirror and baffle along the optical axis. Aluminized mylar MLI in the truss compensates for temperature variations of up to 30 degrees Fahrenheit when the Telescope is in Earth's shadow so the primary and secondary mirrors remain aligned.

The conical secondary mirror subassembly light baffle extends almost to the primary mirror. It reduces the stray bright-object light from sources outside the Telescope FOV.

5.2.3 Focal Plane Structure Assembly

The FPS is a large optical bench that physically supports the science instruments and FGSs and aligns them with the image focal plane of the Telescope. The -V3 side of the structure, away from the Sun in space, supports the FHSTs and RSUs (see

Fig. 5-24). It also provides facilities for on-orbit replacement of any instruments and thermal isolation between instruments.

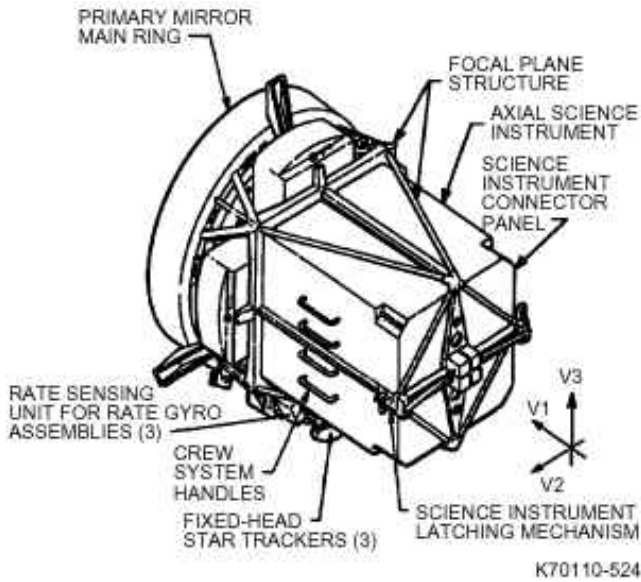

Fig. 5-24 Focal plane structure

The structure is 7 ft (2.1 m) by 10 ft (3.04 m) long and weighs more than 1200 lb (545.5 kg). Because it must have extreme thermal stability and be stiff, lightweight, and strong, the FPS is constructed of graphite-epoxy, augmented with mechanical fasteners and metallic joints at strength-critical locations. It is equipped with metallic mounts and supports for Orbital Replacement Units (ORU) used during maintenance.

The FPS cantilevers off the rear face of the main ring, attached at eight flexible points that adjust to eliminate thermal distortions. The structure provides a fixed alignment for the FGSs. It has guiderails and latches at each instrument mounting location so Shuttle crews can easily exchange science instruments and other equipment in orbit.

5.2.4 OTA Equipment Section

The Equipment Section for the OTA is a large semicircular set of compartments mounted outside the spacecraft on the forward shell of the SSM (see Fig. 5-25). It contains the OTA Electrical Power and Thermal Control Electronics (EP/TCE) System, Fine Guidance Electronics (FGE), Actuator Control Electronics (ACE), Optical Control Electronics (OCE), and the fourth DMS DIU. The OTA Equipment Section has nine bays: seven for equipment storage and two for support. All bays have outward-opening doors for easy astronaut access, cabling and connectors for the electronics, and heaters and insulation for thermal control.

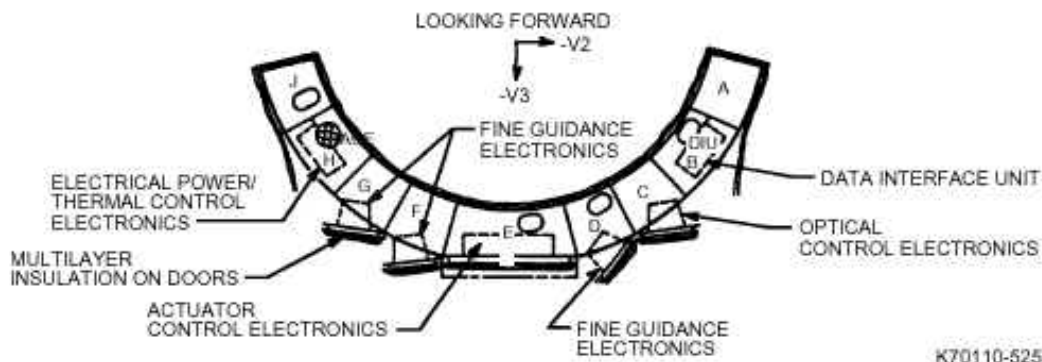

Fig. 5-25 Optical Telescope Assembly Equipment Section

The EP/TCE System distributes power from the SSM EPS and the OTA system. Thermostats regulate mirror temperatures and prevent mirror distortion from the cold of space. The electrical and thermal electronics also collect thermal sensor data for transmission to the ground.

The three FGE units provide power, commands, and telemetry to each FGS. The electronics perform computations for the sensor and interface with the spacecraft pointing system for effective Telescope line-of-sight pointing and stabilization. There is a guidance electronics assembly for each guidance sensor.

The ACE unit provides the command and telemetry interface to the 24 actuators attached to the primary mirror and to the six actuators attached to the secondary mirror. These electronics select which actuator to move and monitor its response to the command. Positioning commands go from the ground to the electronics through the DIU.

The OCE unit controls the optical control sensors. These white-light interferometers measure the optical quality of the OTA and send the data to the ground for analysis. There is one optical control sensor for each FGS, but the OCE unit runs all control sensors. The DIU is an electronic interface between the other OTA electronics units and the Telescope command and telemetry system.

5.3 Fine Guidance Sensor

The three FGSs are located at 90-degree intervals around the circumference of the focal plane structure, between the structure frame and the main ring. Each sensor is 5.4 ft (1.5 m) long and 3.3 ft (1 m) wide and weighs 485 lb (220 kg).

Each FGS enclosure houses a guidance sensor and a wavefront sensor. The wavefront sensors are elements of the optical control sensor used to align and optimize the optical system of the Telescope.

The Telescope's ability to remain pointing at a distant target to within 0.005 arcsec for long periods of time is due largely to the accuracy of the FGSs. They lock on a star and measure any apparent motion to an accuracy of 0.0028 arcsec. This is equivalent to seeing from New York City the motion of a landing light on an aircraft flying over San Francisco.

When two sensors lock on a target, the third measures the angular position of a star, a process called astrometry. Sensor astrometric functions are discussed in Section 4. During SM2 a re-certified FGS (S/N 2001) was installed as a replacement in the HST FGS Bay 1. During SM3A a re-certified FGS (S/N 2002) will be installed in the HST FGS Bay 2.

5.3.1 Fine Guidance Sensor Composition and Function

Each FGS consists of a large structure housing a collection of mirrors, lenses, servos to locate an image, prisms to fine-track the image, beam splitters, and four photomultiplier tubes, as shown in Fig. 5-26. The entire mechanism adjusts to move the Telescope into precise alignment with a target star. Each FGS has a large (60 arcmin \times 2) FOV to search for and track stars, and a 5.0 arcsec \times 2 FOV used by the detector prisms to pinpoint the star.

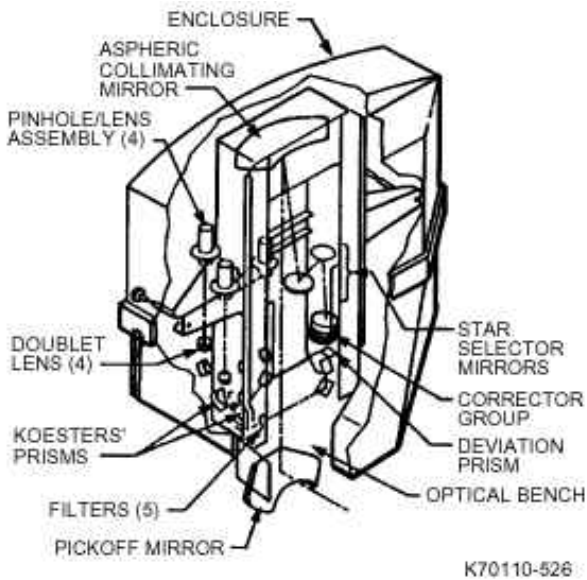

Fig. 5-26 Cutaway view of Fine Guidance Sensor

The sensors work in pairs to aim the Telescope. The Guide Star Selection System, developed by the Science Institute, catalogs and charts guide stars near each observation target to make it easier to find the target. First, one sensor searches for a target guide star. After the first sensor locks onto a guide star, the second sensor locates and locks onto another target guide star. The guide stars, once designated and located, keep the image of the observation target in the aperture of the selected science instrument.

Each FGS uses a 90-degree sector of the Telescope's FOV outside the central "science" field. This region of the FOV has the greatest astigmatic and curvature distortions. The size of the FGS's FOV was chosen to heighten the probability of finding an appropriate guide star, even in the direction of the lowest star population near the galactic poles.

An FGS "pickoff" mirror intercepts the incoming stellar image and projects it into the sensor's large FOV. Each FGS FOV has 60 arcmin² available. The guide star of interest can be anywhere within this field, so the FGS will look anywhere in that field to find it. After finding the star, the sensor locks onto it and sends error signals to the Telescope, telling it how to move to keep the star image perfectly still.

The FGS can move its line of sight anywhere within its large FOV using a pair of star selector servos. Each can be thought of as an optical gimbal: One servo moves in a north-south direction, the other east and west. They steer the small FOV (5 arcsec²) of the FGS detectors to any position in the sensor field. Encoders within each servo system send back the exact coordinates of the detector field centers at any point.

Because the exact location of a guide star may be uncertain, the star selector servos also can cause the detector to search the region around the most probable guide star position. It searches in a spiral pattern, starting at the center and spiraling out until it finds the guide star it seeks. Then the detectors are commanded to go into fine-track mode and hold the star image exactly centered in the FOV, while the star selector servo encoders send information about the position of the star to the spacecraft PCS.

The detectors are a pair of interferometers, called Koester's prisms, coupled to photomultiplier tubes (see Fig. 5-27). Each detector operates in one axis, so two detectors are needed. Operating on the incoming wavefront from the distant guide star, the interferometers compare the wave phase at one edge of the Telescope's entrance aperture with the phase at the opposite edge. When the phases are equal, the star is exactly centered. Any phase difference shows a pointing error that must be corrected.

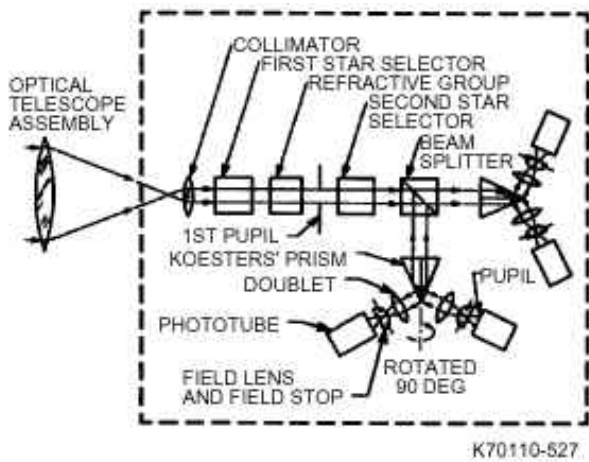

Fig. 5-27 Optical path of Fine Guidance Sensor

Along the optical path from Telescope to detector are additional optical elements that turn or fold the beam to fit everything inside the FGS enclosure, and to correct the Telescope's astigmatism and field curvature. All optical elements are mounted on a temperature-controlled, graphite-epoxy composite optical bench.

5.3.2 Articulated Mirror System

Analysis of the FGS on-orbit data revealed that minor misalignments of the optical pupil centering on Koester's prism interferometer in the presence of spherical aberration prevented the FGS from achieving its optimum performance. During the recertification of FGS (S/N 2001), fold flat #3 in the radial bay module optical train was mechanized to allow on-orbit alignment of the pupil.

Implementation of this system utilized existing signals and commands by rerouting them with a unique interface harness enhancement kit (OCE-EK) interfacing the OCE, the DIU, and the Fine Guidance System/Radial Bay Module (FGS/RBM). The OCE-EK was augmented with the Actuator Mechanism Electronics (AME) and the fold flat #3 Actuator Mechanism Assembly (AMA) located internal to the FGS/RBM. Ground tests indicate a substantial increase in performance of the FGS with this innovative design improvement.

5.4 Solar Array and Jitter Problems

From the beginning, in the late 1970s, the SAs – designed by the European Space Agency and built by British Aerospace, Space Systems – have been scheduled for replacement because of their power loss from radiation exposure in space. However, as engineers put the Telescope through its paces in April 1990, they discovered two problems: a loss of focus and images that jittered briefly when the Telescope flew into and out of Earth's shadow. The jitter problem was traced to the two large SAs. Abrupt temperature changes, from -150 to 200 degrees Fahrenheit during orbit, cause the panels to distort twice during each orbit. As a temporary fix, engineers created software that commanded the PCS to compensate for the jitter automatically. The problem was mitigated during SM1 by the replacement of the old arrays with new ones that had been modified to reduce thermal swings of the bi-stems.

5.4.1 Configuration

The SAs are two large rectangular wings of retractable solar cell blankets fixed on a two-stem frame. The blanket unfurls from a cassette in the middle of the wing. A spreader bar at each end of the wing stretches the blanket and maintains tension. For the replacement SAs delivered to the Telescope during the First Servicing Mission, the spring-loaded roller assembly was replaced by a series of springs connecting the spreader bar to the blanket. This change eliminated the jitter induced into the Telescope as it passed from eclipse (night) into sunlight (day) each orbit.

The wings are on arms that connect to a drive assembly on the SSM forward shell at one end and to the secondary deployment mechanism (blankets and bisters) on the other end. The total length of the cassette, arm, and drive is 15.7 ft (4.8 m) (see Fig. 5-28).

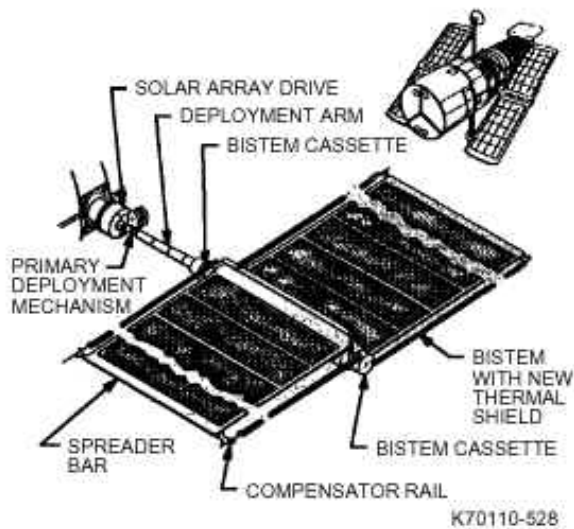

Fig. 5-28 Solar Array wing detail

Each wing has 10 panels that roll out from the cassette. The panels are made of 2438 solar cells attached to a glass-fiber/Kapton surface, with silver mesh wiring underneath, covered by another layer of Kapton. The blankets are less than 500 micrometers thick, so they roll up tightly when the wings are stowed. Each wing weighs 17 lb (7.7 kg) and, at full extension, is 40 ft (12.1 m) long and 8.2 ft (2.5 m) wide.

5.4.2 Solar Array Subsystems

The SA subsystems include the primary and secondary deployment mechanisms, their drives, and associated electronics.

The primary deployment mechanism raises the SA mast from the side of the SSM to a standing position perpendicular to the Telescope. There are two mechanisms, one for each wing. Each mechanism has motors to raise the mast and supports to hold it in place when erect.

An astronaut can raise the array mast manually if the drive power fails. Using a wrench fitting on the deployment drive, the astronaut handcranks the mast after releasing the latches.

Once the SA is raised, the secondary deployment mechanism unfurls the wing blankets. Each wing has a secondary mechanism assembly: a cassette drum to hold solar panels, a cushion to protect the blanket, and motors and subassemblies. The assembly rolls out the blanket, applies tension evenly so the blankets stretch, and transfers data and power along the wing assembly. The blanket can roll out completely or part way. The secondary deployment mechanism also has a manual override (see Fig. 5-29).

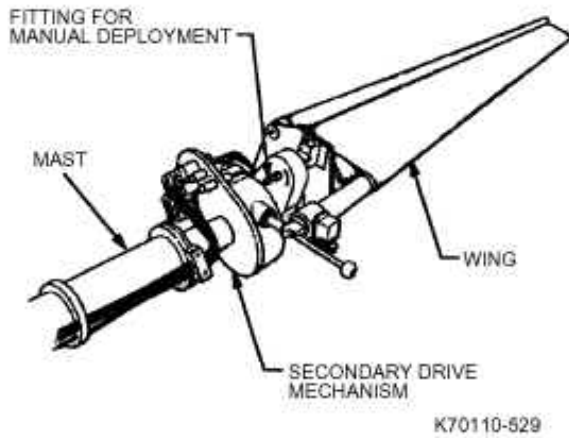

Fig. 5-29 Fitting for Solar Array manual deployment

A SA drive at the base of each mast rotates the deployed array toward the Sun, turning in either direction. Each drive has a motor that rotates the mast on command and a brake to keep the array in a fixed position with respect to the Telescope. The drive can move and lock the SA into any position.

Each drive has a clamp ring that acts as a release mechanism if opened. This allows a crew member to jettison the entire SA if necessary.

Two electronics assemblies (boxes) – the Solar Array Deployment Electronics and the Solar Array Drive Electronics – control and monitor all functions of each SA. They provide the electronic interface to the other Telescope systems and generate the commands for the primary and secondary deployment mechanisms and the SA drive.

5.4.3 Solar Array Configuration for Servicing Mission 3A

The Solar Array wings will remain deployed during servicing. This will allow the Telescope's batteries to remain fully charged during the mission and will not impact servicing activities.

5.5 Science Instrument Control and Data Handling Unit

The SI C&DH unit keeps all science instrument systems synchronized. It works with the DMU to process, format, temporarily store on the data recorders, or transmit all science and engineering data created by the instruments to the ground. Fairchild Camera and Instrument Corporation and IBM built this unit.

5.5.1 Components

The SI C&DH unit is a collection of electronic components attached to an ORU tray mounted on the door of Bay 10 in the SSM Equipment Section (see Fig. 5-30). Small Remote Interface Units (RIU), also part of the system, provide the interface to individual science instruments. Components of the SI C&DH unit are the NASA Standard Spacecraft Computer (NSCC-I), two standard interface circuit boards for the computer, two control units/science data formatter units, two CPU modules, a PCU, two RIUs, and various memory, data, and command communications lines (buses) connected by couplers. The SI C&DH components are redundant so the system can recover from any single failure.

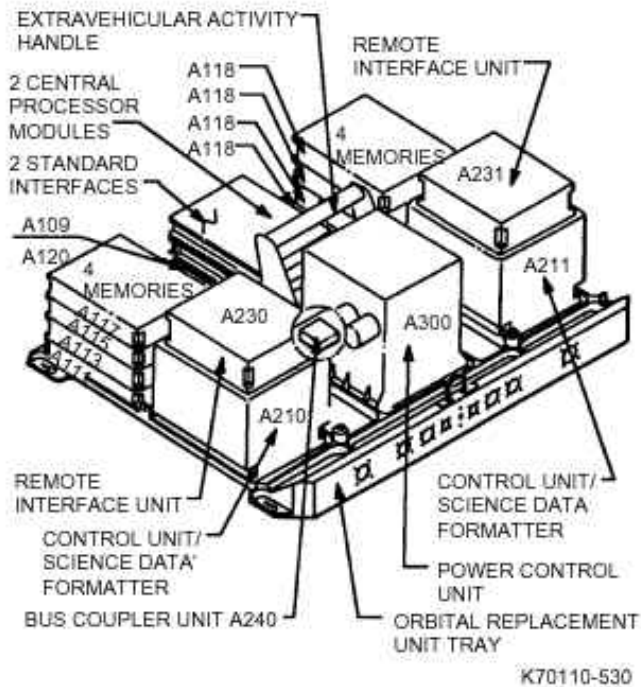

Fig. 5-30 Science Instrument Control and Data Handling unit

NASA Computer.

The NSSC-I has a CPU and eight memory modules, each holding 8,192 eighteen-bit words. One embedded software program (the "executive") runs the computer. It moves data, commands, and operation programs (called applications) for individual science instruments in and out of the processing unit. The application programs monitor and control specific instruments and analyze and manipulate the collected data. The memory stores operational commands for execution when the Telescope is not in contact with the ground. Each memory unit has five areas reserved for commands and programs unique to each science instrument. The computer can be reprogrammed from the ground for future requests or for working around failed equipment.

Standard Interface Unit.

The standard interface board is the communications bridge between the computer and the CU/SDF.

Control Unit/Science Data Formatter.

The heart of the SI C&DH unit is the CU/SDF. It formats and sends all commands and data to designated destinations such as the DMU of the SSM, the NASA computer, and the science instruments. The unit has a microprocessor for control and formatting functions.

The CU/SDF receives ground commands, data requests, science and engineering data, and system signals. Two examples of system signals are "time tags," clock signals that synchronize the entire spacecraft, and "processor interface tables," or communications codes. The CU/SDF transmits commands and requests after formatting them so that the specific destination unit can read. For example, ground commands and SSM commands are transmitted with different formats. Ground commands use 27-bit words, and SSM commands use 16-bit words. The formatter translates each command signal into a common format. The CU/SDF also reformats and sends engineering and science data. Onboard analysis of the data is an NSSC-I function.

Power Control Unit.

The PCU distributes and switches power among components of the SI C&DH unit. It conditions the power required by each unit. For example: The computer memory boards typically need +5 volts, -5 volts, and +12 volts; the CU/SDF, on the other hand, requires +28 volts. The PCU ensures that all voltage requirements are met.

Remote Interface Units.

RIUs transmit commands, clock and other system signals, and engineering data between the science instruments and the SI C&DH unit. The RIUs do not send science data. There are six RIUs in the Telescope: five attached to the science instruments and one dedicated to the CU/SDF and PCUs in the SI C&DH unit. Each RIU can be coupled with up to two expander units.

Communications Buses.

The SI C&DH unit contains data bus lines that pass signals and data between the unit and the science instruments. Each bus is multiplexed: one line sends system messages, commands, and engineering data requests to the module units, and a reply line transmits requested information and science data back to the SI C&DH unit. A coupler attaches the bus to each remote unit. This isolates the module if the RIU should fail. The SI C&DH coupler unit is on the ORU tray.

5.5.2 Operation

The SI C&DH unit handles science instrument system monitoring (such as timing and system checks), command processing, and data processing.

System Monitoring.

Engineering data tells the monitoring computer whether instrument systems are functioning. At regular intervals, varying from every 500 milliseconds to every 40 seconds, the SI C&DH unit scans all monitoring devices for engineering data and passes data to the NSCC-I or SSM computer. The computers process or store the information. Any failure indicated by these constant tests could initiate a "safing hold" situation (see para 5.1.7), and thus a suspension of science operations.

Command Processing.

Figure 5-31 shows the flow of commands within the SI C&DH unit. Commands enter the CU/SDF (bottom right in the drawing) through the SSM Command DIU (ground commands) or the DIU (SSM commands). The CU/SDF checks and reformats the commands, which then go either to the RIUs or to the NSCC-I for storage. "Time-tagged" commands, stored in the computer's memory (top right of drawing), also follow this process.

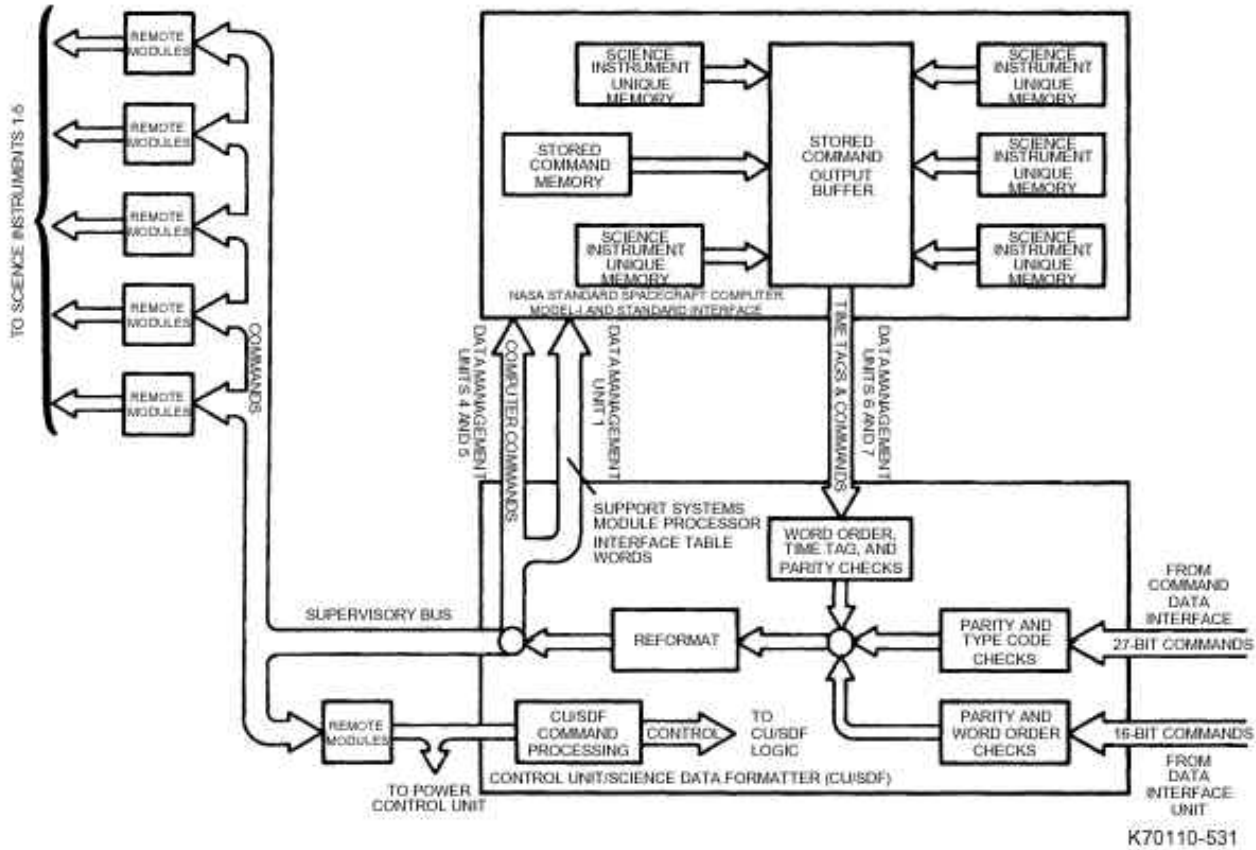
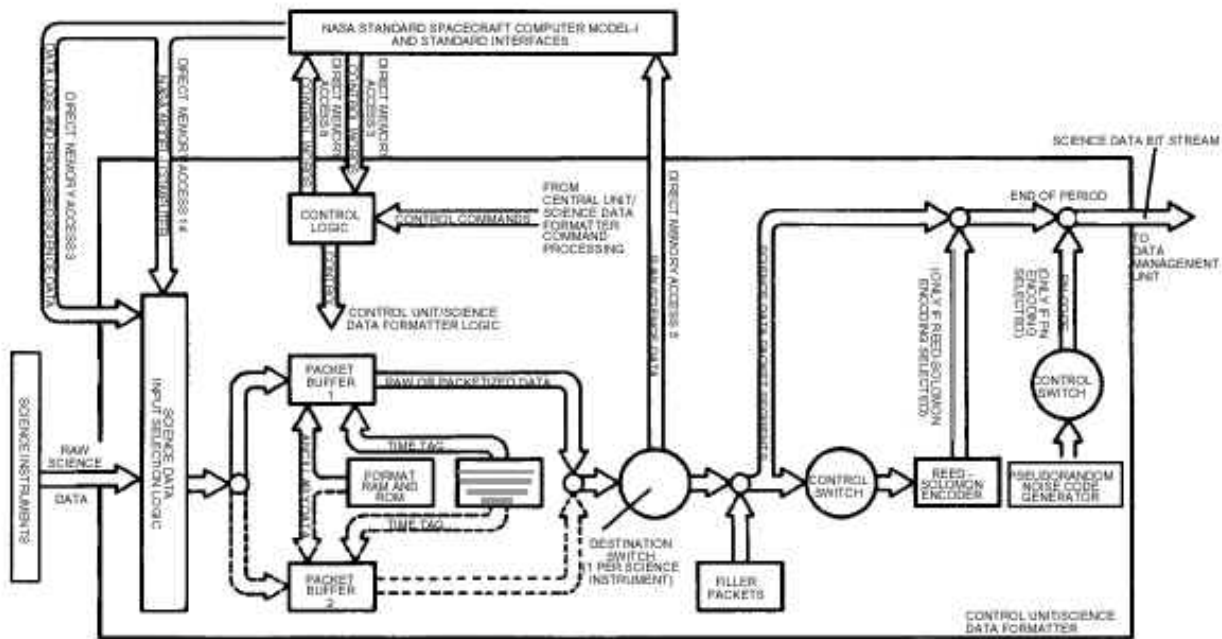

Fig. 5-31 Command flow for Science Instrument Control and Data Handling unit

Each command is interpreted as "real time," as if the SI C&DH just received it. Many commands actually are onboard stored commands activated by certain situations. For example, when the Telescope is positioned for a programmed observation using the Space Telescope Imaging Spectrograph, that program is activated. The SI C&DH can issue certain requests to the SSM, such as to execute a limited number of pointing control functions to make small Telescope maneuvers.

Science Data Processing.

Science data can come from all science instruments at once. The CU/ SDF transfers incoming data through computer memory locations called packet buffers. It fills each buffer in order, switching among them as the buffers fill and empty. Each data packet goes from the buffer to the NSCC-I for further processing, or directly to the SSM for storage in the data recorders or transmission to the ground. Data returns to the CU/SDF after computer processing. When transmitting, the CU/ SDF must send a continuous stream of data, either full packet buffers or empty buffers called filler packets, to maintain a synchronized link with the SSM. Special checking codes (Reed-Solomon and pseudo-random noise) can be added to the data as options. Figure 5-32 shows the flow of science data in the Telescope.



K70110-532

Fig. 5-32 Flow of science data in the Hubble Space Telescope

5.6 Space Support Equipment

The Hubble Space Telescope was designed to be maintained, repaired, and enhanced while in orbit, extending its life and usefulness. For servicing, the Space Shuttle will capture and position the Telescope vertically in the aft end of the cargo bay, and the crew will perform maintenance and replacement tasks. The Space Support Equipment (SSE) to be used during the mission provides a maintenance platform to hold the Telescope, provides electrical support of the Telescope during servicing, and provides storage for replacement components known as ORUs.

The major SSE items used for the Servicing Mission 3A are the Flight Support System (FSS) and the ORU Carrier (ORUC). Additionally, crew aids and tools will be used during servicing.

5.6.1 Flight Support System

The FSS provides the platform that holds the Telescope during servicing (see Fig. 5-33). The FSS has been used in different configurations for the HST First and Second Servicing Missions, the Solar Maximum Repair Mission, and the Upper Atmospheric Research Satellite Deploy Mission. The FSS consists of two major components: a horseshoe-shaped cradle and a supporting latch beam providing a structural and electrical interface with the Shuttle. A circular ring called the Berthing and Positioning System (BAPS) interfaces with the Telescope, allowing it to pivot or rotate during the mission.

FSS – AFT VIEW

AMSB: Advanced Mechanism Selection Box
 CEP: Contamination Environment Package
 CMP: Contamination Monitoring Package
 EPDSU: Enhanced Power Distribution & Switching Unit
 IPCU: Interface Power Control Unit
 PDSU: Power Distribution & Switching Unit
 PPCU: Port Power Conditioning Unit
 SIP: Standard Interface Panel
 SPCU: Starboard Power Conditioning Unit

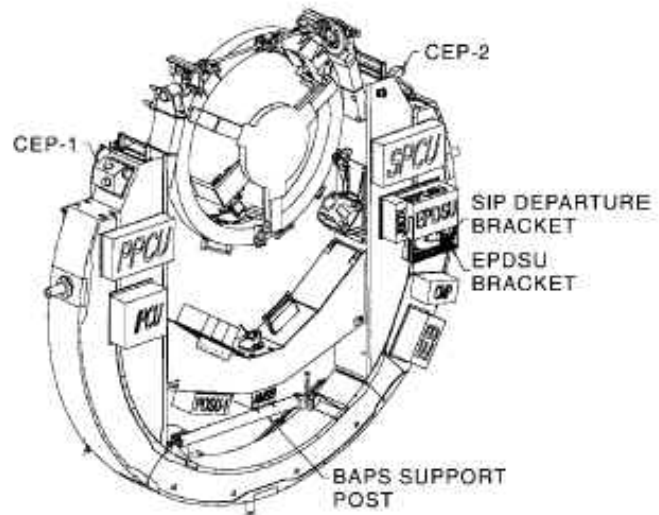

K9322_203

Fig. 5-33 Flight Support System configuration

The BAPS ring is pivoted down and locked for liftoff. During the mission, the ring is pivoted up to a horizontal position. A closed-circuit television camera mounted to the FSS helps astronauts guide the Telescope onto the ring. Three remote-controlled latches on the ring grab and hold three towel-rack-like pins on the rear of the Telescope. A remote-controlled electrical umbilical connector on the FSS engages the Telescope, providing it with orbiter power through the FSS. This power helps relieve the drain on the Telescope's batteries during the mission. Radio communications provide telescope telemetry data and control.

Once the Telescope is berthed to the ring (see Fig. 5-34), the FSS can pivot (tilt) or rotate the Telescope. This positions the appropriate region of the Telescope for access during extravehicular activity. Additionally, the ring can pivot the Telescope to an appropriate attitude for orbiter reboost.

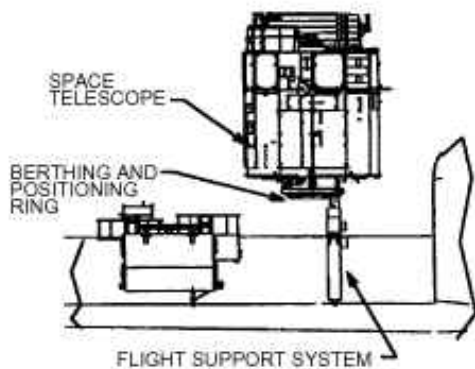

K70110-534

Fig. 5-34 Flight Support System Berthing and Positioning System ring pivoted up with Telescope berthed

During the first EVA, crew members will install the BAPS Support Post (BSP). The BSP provides an additional linkage to support and isolate Telescope during EVAs and for any orbital reboosts. The BSP will remain in position for landing.

Astronauts remotely control all FSS mechanisms – berthing latches, umbilical connector, pivoter, BSP lock, rotator, and ring down-lock – from the orbiter's aft flight deck, providing the crew maximum flexibility. Besides being fully electrically redundant, each mechanism contains manual overrides and backups to ensure mission success and astronaut safety.

5.6.2 Orbital Replacement Unit Carrier

An ORUC is used to carry replacements into orbit and to return replaced units to Earth. The carrier consists of a Spacelab pallet outfitted with shelves and protective enclosures to hold the replacement units (see Fig. 5-35). Items on the ORUC for SM3A include (1) the Advanced Computer and two spare VIKs in the LOPE and (2) a Solid State Recorder, an S-Band Single Access Transmitter, the Rate Sensor Units, and associated flight harnesses in the COPE.

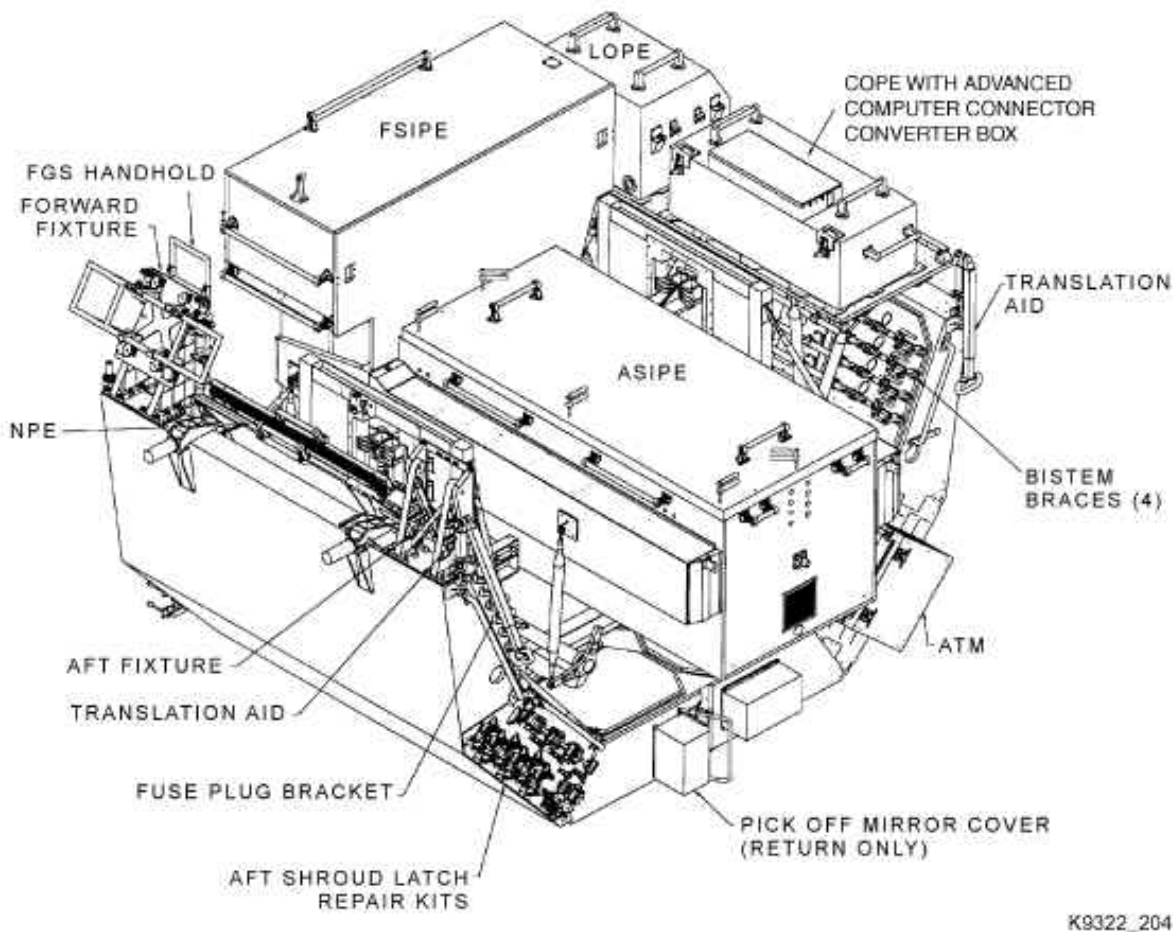

Fig. 5-35 Orbital Replacement Unit Carrier

The FGS will be transported in the FGS Scientific Instrument Protective Enclosure (FSIPE). A spare Advanced Computer, a spare Rate Sensor Unit, and Multi-Layer Insulation patches will be carried in the Axial Scientific Instrument Protective Enclosure (ASIPE). The NOBL will be carried in a NOBL Protective Enclosure (NPE).

All ORUs and scientific instruments are carried within protective enclosures to provide them a benign environment throughout the mission. The enclosures protect the instruments from contamination and maintain the temperature of the instruments or ORUs within tight limits.

Instruments are mounted in the enclosures using the same manually driven latch system that holds instruments in the Telescope. The ASIPE and FSIPE are mounted to the pallet on a spring system that reduces the level of vibration the instruments receive, especially during liftoff and landing.

The other ORUs are carried in an additional enclosure called the Large ORU Protective Enclosure (LOPE). The enclosure also provides contamination and thermal control, though not to such stringent requirements as the SIPE. The LOPE contains Transport Modules that are designed to custom fit each ORU. The transport modules have foam or Visco-Elastic Material that surrounds the ORU and isolates it from launch and landing vibration environments.

During the change-out process, replaced science instruments are stored temporarily in the ORUC. A typical change-out begins with an astronaut removing the old instrument from the Telescope and attaching it to a bracket on the ORUC. The astronaut then removes the new instrument from its protective enclosure and installs it in the Telescope. Finally, the astronaut places the old instrument in the appropriate protective enclosure for return to Earth.

The ORUC receives power for its TCS from the FSS. The carrier also provides temperature telemetry data through the FSS for readout in the Shuttle and on the ground during the mission.

5.6.3 Crew Aids

Astronauts perform extravehicular activities using many tools to replace instruments and equipment, to move around the Telescope and the cargo bay, and to operate manual override drives. Tools and equipment, bolts, connectors, and other hardware were standardized not only for the Telescope but also between the Telescope and the Shuttle. For example, grappling receptacles share common features.

To move around the Telescope, the crew uses 225 ft of handrails encircling the spacecraft. For visibility, the rails are painted yellow. In addition, the crew can hold onto guiderails, trunnion bars, and scuff plates fore and aft.

The astronauts can install portable handhold plates where there are no permanent holds, such as on the FGS. Another tool is the Portable Foot Restraint (PFR), shown in Fig. 5-36.

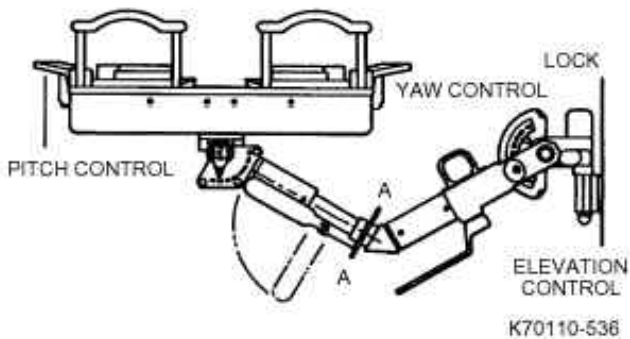

Fig. 5-36 Portable Foot Restraint

While the astronauts work, they use tethers to hook tools to their suits and tie replacement units to the Telescope. Each crew member has a ratchet wrench to manually crank the antenna and array masts if power for the mast drives fails. A power wrench also is available if handcranking is too time consuming. Other hand tools include portable lights and a jettison handle, which attach to sockets on the aperture door and to SA wings so the crew can push the equipment away from the Telescope.

HST OPERATIONS

Hubble Space Telescope operations are of two types: science operations that plan and conduct the HST science program – observing celestial objects and gathering data – and mission operations that command and control HST to implement the observation schedule and maintain the Telescope’s overall performance.

Science and mission operations often coincide and interact. For example, a science instrument may observe a star and calibrate incoming wavelengths against standards developed during scientific verification. Mission operations monitor observations to ensure that Telescope subsystems have functioned correctly.

Mission operations are carried out by the Telescope ground system, which consists of facilities at the Space Telescope Science Institute (STScI), and the Space Telescope Operations Control Center (STOCC), the Packet Processing Facility (PACOR), and other institutional facilities at the Goddard Space Flight Center (GSFC).

The STScI oversees science operations. It hosts astronomers, evaluates and chooses observation programs, schedules the selected observations, generates an overall mission timeline and command sequences, and stores and analyzes science data from the Telescope. Meanwhile, the flight operations team conducts mission operations from the STOCC. The team interacts with the STScI to receive daily mission schedules, to process engineering data and displays, and to manage the engineering data archive.

6.1 Space Telescope Science Institute

Located in Baltimore, Maryland, STScI is responsible to GSFC for the science programs on the HST. It is operated by the Association of Universities for Research in Astronomy (AURA), a consortium of 29 United States universities that operate several national facilities for astronomy.

STScI solicits and reviews observation proposals and selects observations to be carried out. It schedules observations and assists guest observers in their work; generates an integrated science and engineering timeline to support all spacecraft activities, including any special engineering tests; and provides the facilities and software to reduce, analyze, archive, and distribute Telescope data.

STScI also monitors the Telescope and science instruments for characteristics that could affect science data collection, such as instrument performance quality, pointing inaccuracies, and Telescope focus.

6.1.1 Scientific Goals

STScI helps conduct the science program to meet the overall scientific goals of the Telescope program, set by the Institute and NASA in consultation with AURA's Space Telescope Institute Council and committees representing the international astronomical community.

6.1.2 Institute Software

Computer hardware and software play an important role in STScI work. The STScI ground system consists of a planning and scheduling system and a science data processing system. The STScI also created the guide star catalog used to support the precise pointing requirements of the HST pointing control subsystem. In addition, Science Data Analysis Software (SDAS) provides analytical tools for astronomers studying observational data.

STScI handles mission planning and scheduling, observation support, software support, and routine data processing. Together, these functions perform computations needed to run the science operations on the Telescope.

As part of the Planning and Scheduling System, the STScI Guide Star Selection System (GSSS) provides reference stars and other bright objects so the Fine Guidance Sensors (FGS) can point the Telescope accurately. This system selects guide stars that can be located unambiguously in the sky when the sensors point the Telescope. The guide star catalog has information on 20 million celestial objects, created from 1,477 photographic survey plates covering the entire sky.

After the STScI Science Data Pipeline collects, edits, measures, and archives science data, observers can use SDAS to analyze and interpret the data.

6.1.3 Selecting Observation Proposals

Astronomers worldwide may use the Telescope. Any scientist may submit a proposal to the STScI outlining an observing program and describing the scientific objectives and instruments required. The STScI selects observations by evaluating these requests for technical feasibility, conducting peer reviews, and choosing the highest ranked proposals. Because individual astronomers and astronomy teams submit many more proposals than can possibly be accepted, a team approach is encouraged. The final decision rests with the STScI director, advised by a review committee of astronomers and scientists from many institutions.

6.1.4 Scheduling Selected Observations

The primary scheduling consideration is availability of a target, limited by environmental and stray-light constraints – for example, a faint object that must be observed when the Telescope is in Earth’s shadow. The schedule takes into consideration system limits, observations that use more than one instrument, and required time for special observations.

6.1.5 Data Analysis and Storage

STScI archives calibrated science data. Computer resources include the Hubble Data Archive, SDAS and other selected computer facilities.

Science Data Pipeline processing receives science data from the PACOR at GSFC, then automatically formats it and verifies its quality. It calibrates data to remove the instrument’s properties such as variation in the detector’s sensitivity across the data field. Then the software places the data on digital archive media from which the data can be formatted and distributed to the observer or archival researcher. The STScI processes all data within 24 hours after receipt.

STScI is responsible for storing the massive amount of data collected by the Telescope. The Hubble Data Archive catalog records the location and status of data as it pours into the storage banks. Observers and visiting astronomers can easily retrieve the stored data for examination or use data manipulation procedures created by the STScI. The European Space Agency (ESA) provides approximately 15 staff members collocated with STScI staff and operates its own data analysis facility in Garching, Germany.

In addition to science data, the STScI stores engineering data. This is important for developing more efficient use of the Telescope systems and for adjusting Telescope operations based on engineering findings, for example, if an instrument provides unreliable data in certain temperature ranges.

6.2 Space Telescope Operations Control Center

The STOCC flight operation team runs day-to-day spacecraft operations. In addition, the STOCC team works with the NASA Communications Network (NASCOM) and the Tracking and Data Relay Satellite System (TDRSS) to facilitate HST data communications.

POCC uses mission-control facilities at GSFC built specifically for HST operations. The Vision 2000 Control Center System (CCS) has been developed to provide the next generation of operational capabilities in the STOCC. Built specifically to support the HST Third Servicing Missions (SM3A and SM3B), the CCS provides distributed capabilities with a completely new user interface that is on the forefront of spacecraft operations.

STOCC has three major operational responsibilities:

- Spacecraft operations, including sending commands to the spacecraft
- Telemetry processing
- Offline support.

Most specific spacecraft operations are executed based on time-tagged commands managed by the Telescope's onboard software. The STOCC flight operations team, using the CCS, uplinks the commands to the HST computers.

Engineering telemetry, received in the STOCC from the GSFC institutional communication system, provides information that reflects the HST spacecraft subsystem status. For example, telemetry can verify Pointing Control System operation and stability performance of the Telescope. In many cases, consultation between STOCC and STScI is necessary, particularly if the data affects an ongoing observation.

An important part of the ground system is PACOR processing. When data arrives from NASCOM for science handling, PACOR reformats the data, checks for noise or transmission problems, and passes each packet of data along to the STScI with a data quality report.

Another important STScI function is to support observers requiring a "quick-look" analysis of data. STScI alerts PACOR to that need, and the incoming data can be processed for the observer.

TDRSS has two communications relay satellites 130 degrees apart, with a ground terminal at White Sands, New Mexico. There is a small "zone of exclusion" where Earth blocks the Telescope signal to either of the satellites, but up to 91 percent of the Telescope's orbit is within communications coverage. Tracking and Data Relay Satellites (TDRS) receive and send both single-access (science data) and multiple-access (commands and engineering data) channels.

6.3 Operational Characteristics

Three major operational factors affect the success of the Telescope: orbital characteristics for the spacecraft, its maneuvering characteristics, and communications characteristics for sending and receiving data and commands.

6.3.1 Orbital Characteristics

The orbit of the Telescope is approximately 320 nmi (593 km). The orbit inclines at a 28.5-degree angle from the equator because the Shuttle launch was due east from Kennedy Space Center. The chosen orbit puts the Sun in the Telescope orbital plane so that sunlight falls more directly on the Solar Arrays. In addition, the orbit is high enough that aerodynamic drag from the faint atmosphere will not decay the Telescope's orbit to below the minimum operating altitude.

The Telescope completes one orbit every 97 minutes, passing into the shadow of the Earth during each orbit. The time in shadow varies from 28 to 36 minutes. The variation during a nominal 30-day period is between 34.5 and 36 minutes in shadow. If Earth blocks an object from the Telescope, the Telescope reacquires the object as the spacecraft comes out of Earth's occultation. Faint-object viewing is best while the Telescope is in Earth's shadow.

The Telescope orbit is tracked by the TDRSS, which plots the spacecraft's orbit at least eight times daily and sends the data to the Flight Dynamics Facility at GSFC. Although this helps predict future orbits, some inaccuracy in predicting orbital events, such as exit from Earth's shadow, is unavoidable. The environmental elements with greatest effect on the Telescope's orbit are solar storms and other solar activities. These thicken the upper atmosphere and increase the drag force on the Telescope, accelerating the orbit decay rate considerably.

6.3.2 Celestial Viewing

The Telescope is pointed toward celestial targets as a normal orientation to expose instrument detectors for up to 10 hours, if needed. A continuous-viewing zone exists, parallel to the orbit plane of the Telescope and up to 18 degrees on either side of the north and south poles of that orbital plane (see Fig. 6-1). Otherwise, celestial viewing depends on how long a target remains unblocked by Earth.

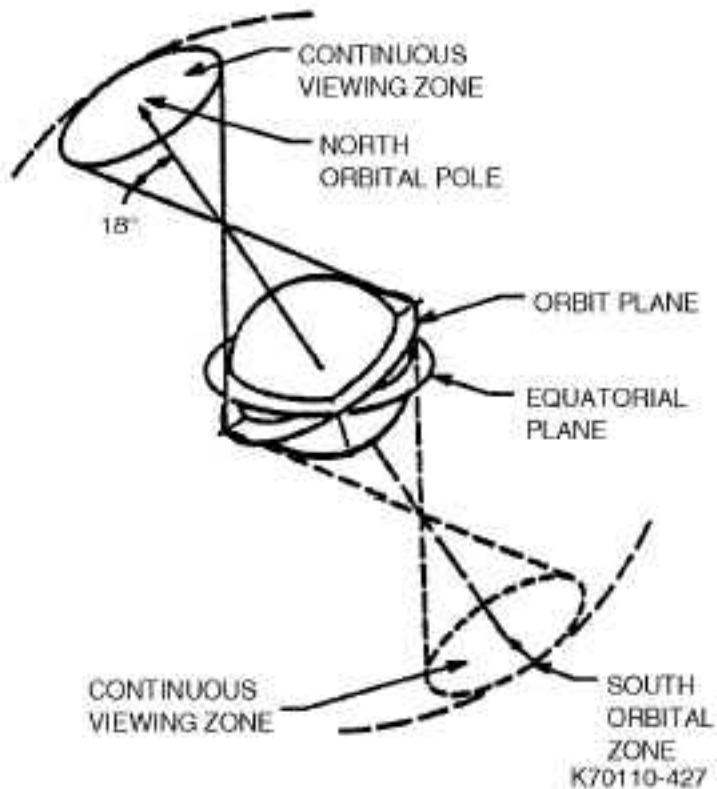

Fig. 6-1 "Continuous-zone" celestial viewing

The amount of shadow time available for faint-object study also affects celestial observations. Shadow time for an observation varies with the time of year and the location of the target relative to the orbit plane. Astronomers use a geometric formula to decide when in a given period a target will be most visible while the Telescope is in shadow.

Other sources affecting celestial viewing are zodiacal light and integrated or background starlight.

6.3.3 Solar System Object Viewing

Solar system objects also are affected by the factors mentioned for celestial viewing. In addition, the Telescope works with imprecise orbit parameters for itself and objects such as the outer planets and comets. For example, Neptune's center may be off by 21 km when the sensors try to lock onto it because the Telescope is changing its position in orbit, which affects the pointing direction toward nearby objects. However, most solar system objects are so bright the Telescope needs only a quick snapshot of the object to fix its position. Tracking inaccuracies are more likely to cause a blurred image if they occur with long-exposure observations of dim targets.

The Telescope's roll attitude also may affect the view of the object and require a maneuver that rolls the spacecraft more than the 30-degree limit – for example, to place the image into a spectrographic slit aperture.

Tracking interior planets (Mercury and Venus) with the Telescope places the Sun within the Telescope opening's 50-degree Sun-exclusion zone. For this reason, HST never observes Mercury and has observed Venus only once, using Earth to block (occlude) the Sun.

6.3.4 Natural Radiation

Energetic particles from different sources bombard the Telescope continuously as it travels around the Earth. Geomagnetic shielding blocks much of the solar and galactic particle radiation. When the Telescope passes through the South Atlantic Anomaly (SAA), a "hole" in Earth's magnetic field, charged particles can enter the Telescope and strike its detectors, emitting electrons and producing false data.

The Telescope passes through the SAA for segments of eight or nine consecutive orbits, then has no contact with it for six or seven orbits. Each encounter lasts up to 25 minutes. In addition, the SAA rotates with Earth, so it occasionally coincides with the Telescope as the spacecraft enters Earth-shadow observation periods. Careful scheduling minimizes the effects of the anomaly, but it has some regular impact.

Solar flares are strong pulses of solar radiation, accompanied by bursts of energetic particles. Earth's magnetic field shields the lower magnetic latitude regions, such as the Telescope's orbit inclination, from most of these charged particles. NASA regularly monitors the flares, and the Telescope can stop an observation until the flares subside.

6.3.5 Maneuver Characteristics

The Telescope changes its orientation in space by rotating its reaction wheels, then slowing them. The momentum change caused by the reaction moves the spacecraft at a baseline rate of 0.22 degree per second or 90 degrees in 14 minutes. Figure 6-2 shows a roll-and-pitch maneuver.

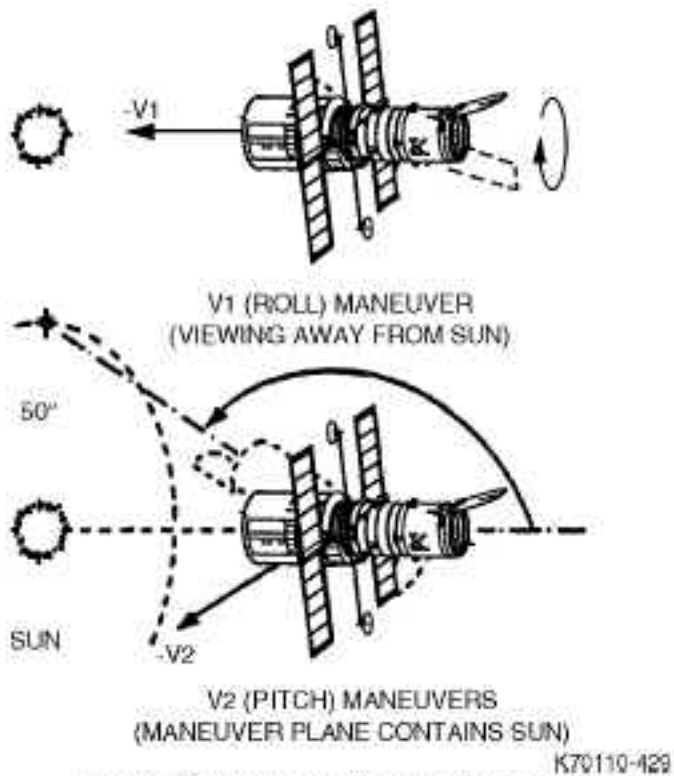

Fig. 6-2 HST single-axis maneuvers

When the Telescope maneuvers, it takes a few minutes to lock onto a new target and accumulate drift errors. This means that a larger region of the sky must be scanned for guide stars.

One consideration with maneuvering is the danger of moving the Solar Array wings out of the Sun's direct radiation for too long. Unprotected portions of the Support Systems Module aft shroud could be affected thermally. Therefore, maneuvers beyond a certain range in angle and time are limited.

When the Telescope performs a pitch to a target near the 50-degree Sun-avoidance zone, the Telescope curves away from the Sun. For example, if two targets are opposed at 180 degrees just outside the 50-degree zone, the Telescope follows an imaginary circle of 50 degrees around the Sun until it locates the second target (see Fig. 6-3).

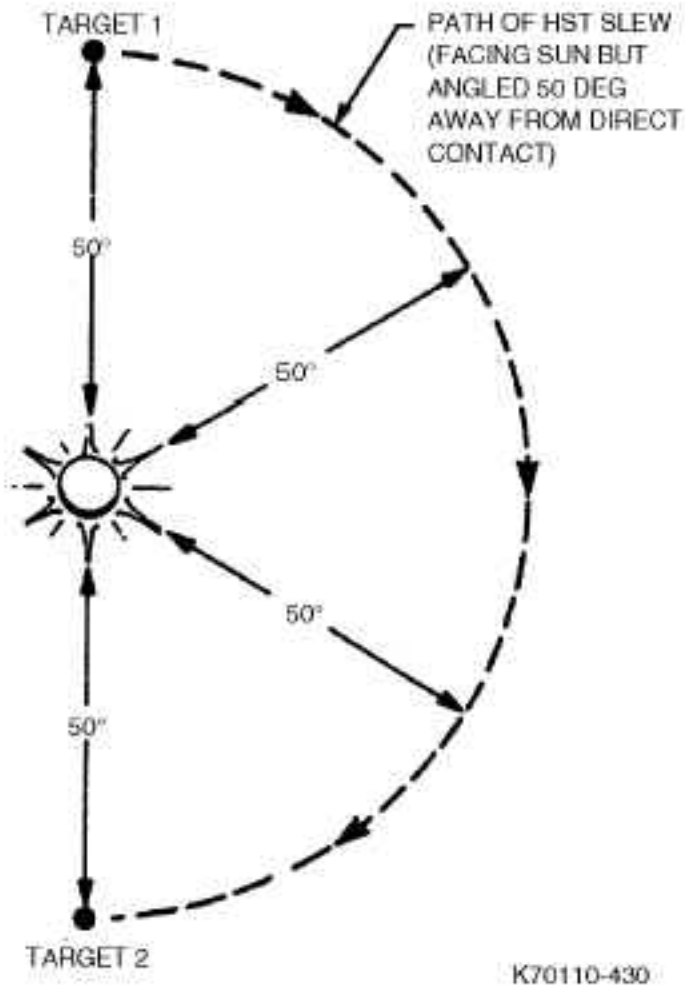

Fig. 6-3 Sun-avoidance maneuver

6.3.6 Communication Characteristics

The Telescope communicates with the ground via TDRSS. With two satellites 130 degrees apart in longitude, the maximum amount of contact time is 94.5 minutes of continuous communication, with only 2.5 to 7 minutes in a zone of exclusion out of reach of either TDRS (see Fig. 6-4). However, orbital variations by the Telescope and communications satellites affect this ideal situation to slightly widen the zone of exclusion.

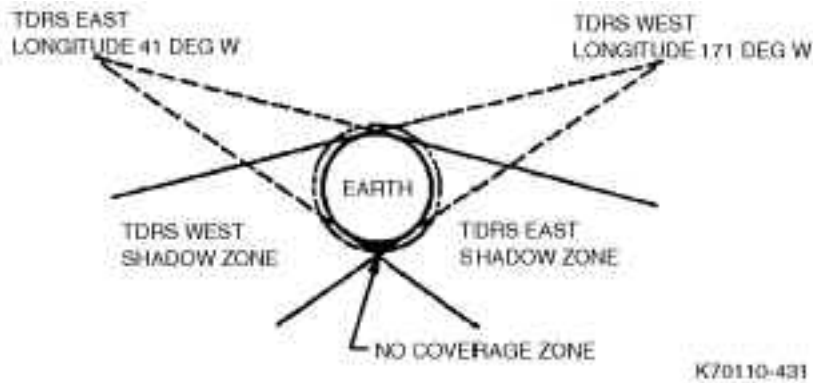

Fig. 6-4 TDRS-HST contact zones

The GSFC Network Control Center (NCC) schedules all TDRS communications. The Telescope has a general orbital communication schedule, supplemented by specific science requests. The NCC prepares schedules 14 days before the start of each mission week.

The backup communications link is the Ground Network, which receives engineering data or science data if the High Gain Antennas (HGA) cannot transmit to TDRSS. The longest single contact time is 8 minutes. The limiting factor of this backup system is the large gap in time between contacts with the Telescope. In practical terms, at least three contacts are required to read data from a filled science data recorder – with gaps of up to 11 hours between transmissions.

Each HGA maintains continuous contact with one TDRS to avoid unnecessary gaps in communication. Each antenna tracks the communication satellite, even during fine-pointing maneuvers.

Low Gain Antennas provide at least 95 percent orbital coverage via a TDRS for the minimum multiple-access command rate used.

6.4 Acquisition and Observation

The major steps in the observation process are target acquisition and observation, data collection and transmission, and data analysis.

Each science instrument has an entrance aperture, located in different portions of the Hubble's focal plane. The different aperture positions make precise pointing a sometimes-lengthy procedure for the FGSs, which must center the target in small apertures. Additional time is required to reposition the Telescope – an estimated 18 minutes to maneuver 90 degrees plus the time the sensors take to acquire the guide stars. If the Telescope overshoots its target, the Fixed Head Star Trackers may have to make coarse-pointing updates before the Telescope can use the FGSs again.

To increase the probability of a successful acquisition, Telescope flight software allows the use of multiple guide-star pairs to account for natural contingencies that might affect a guide-star acquisition – such as a guide star being a binary star and preventing the FGSs from getting a fine lock on the target. Therefore, an observer can submit a proposal that includes a multiple selection of guide-star pairs. If one pair proves too difficult to acquire, the sensors can switch to the alternate pair. However, each observation has a limited total time for acquiring and studying the target. If the acquisition process takes too long, the acquisition logic switches to coarse-track mode for that observation to acquire the guide stars.

Three basic modes are used to target a star.

- Mode 1 points the Telescope, then transmits a camera image, or spectrographic or photometric pseudoimage, to STOCC. Ground computers make corrections to precisely point the Telescope, and the coordinates pass up through the Advanced Computer.
- Mode 2 uses onboard facilities, processing information from the larger target apertures, then aiming the Telescope to place the light in the chosen apertures.
- Mode 3 uses the programmed target coordinates in the star catalog or updated acquisition information to reacquire a previous target. Called blind pointing, this is used mostly for generalized pointing and for the Wide Field and Planetary Camera 2, which does not require such precise pointing. Mode 3 relies increasingly on the updated guide-star information from previous acquisition attempts, stored in the computer system.

VALUE ADDED: The Benefits of Servicing Hubble

One of the most important features of the Hubble Space Telescope is its ability to be maintained and upgraded on orbit. Every few years, a team of astronauts carries a full manifest of new equipment on the Space Shuttle for the ultimate "tune-up" in space.

The Telescope was being designed as the Space Shuttle was being readied for its first flights. NASA realized that if a shuttle crew could service HST, it could be upgraded and maintained indefinitely. So from the beginning, Hubble was designed to be modular and astronaut-friendly.

Its modular design allows NASA to equip HST with new, state-of-the-art scientific instruments every few years – giving the Telescope exciting new capabilities with each servicing mission (see Fig. 7-1).

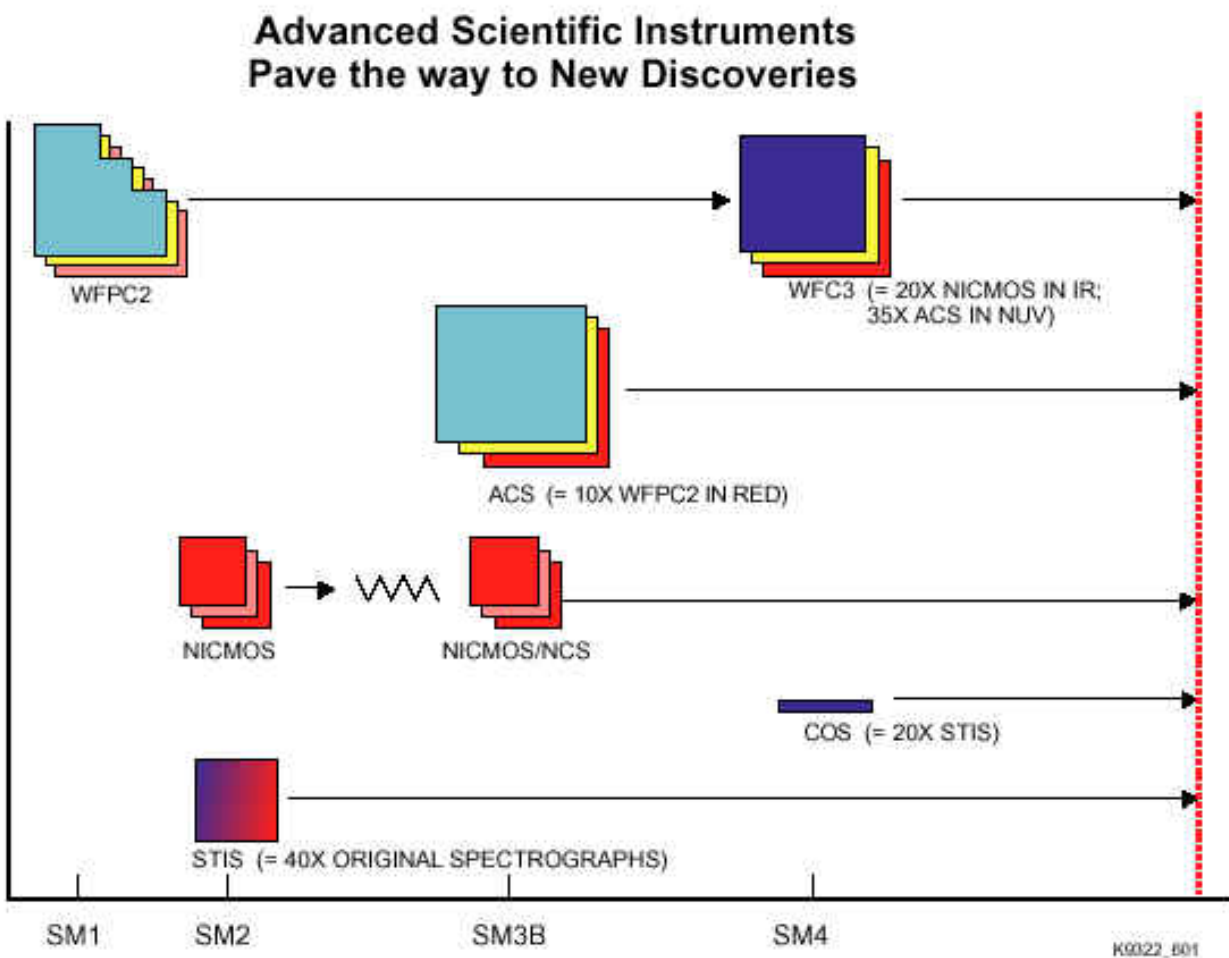

Fig. 7-1 Advanced scientific instruments installed (or to be installed) on HST

In addition to science upgrades, the servicing missions permit astronauts to replace limited-life components with systems incorporating the latest technology (see Fig. 7-2).

Spacecraft Equipment Change-Outs To Enhance Mission Life, Reliability and Productivity

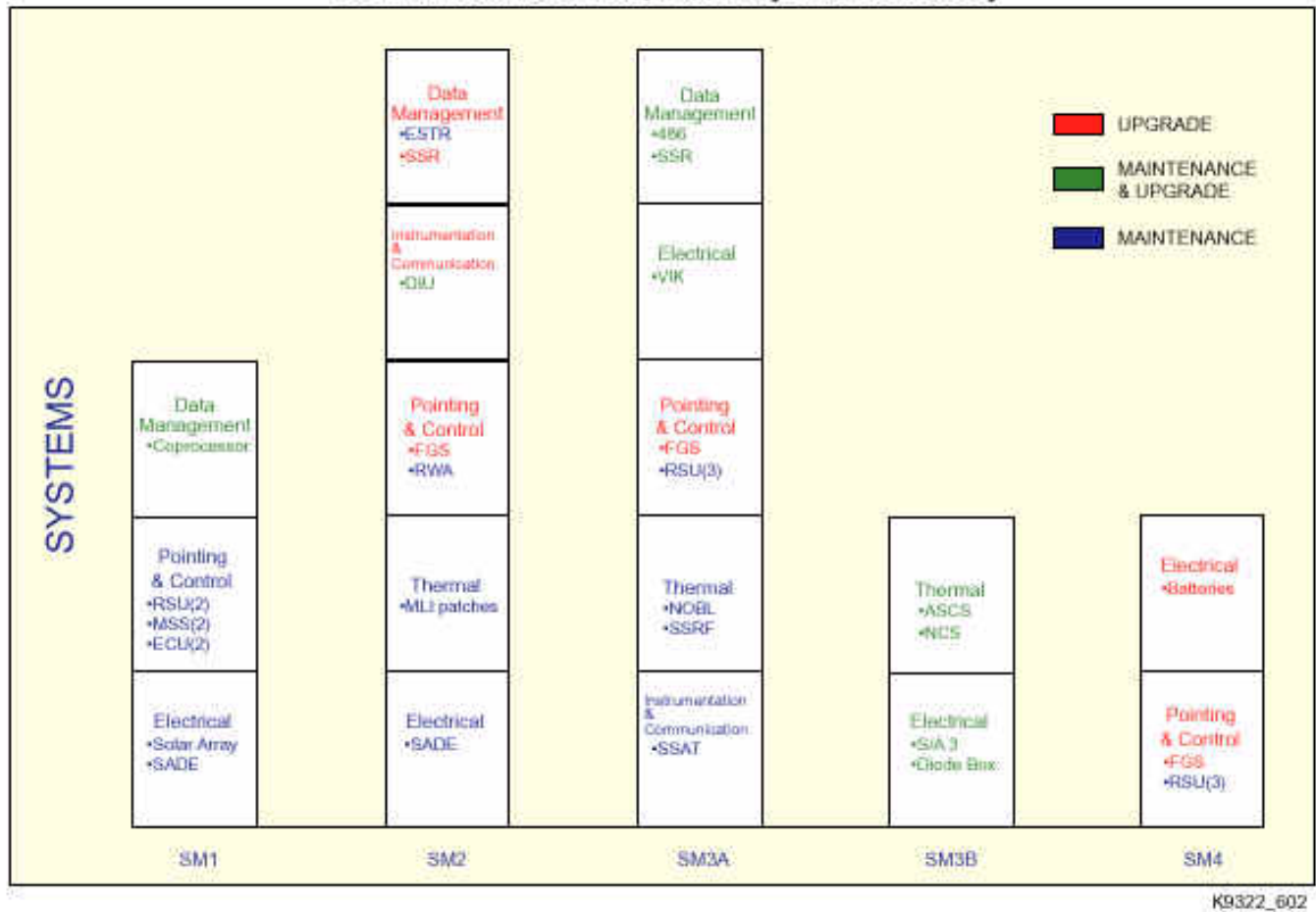

Fig. 7-2 Systems maintained and upgraded during each servicing mission

7.1 Cost-Effective Modular Design

In February 1997 astronauts installed two next-generation scientific instruments, giving the Telescope infrared and ultraviolet vision. At the same time, they installed a state-of-the-art Solid State Recorder (SSR) to increase Hubble's observing capability. The 1993 and 1997 servicing missions increased scientific exposure time efficiencies 11-fold.

On Servicing Mission 3B (SM3B), scheduled for 2000, astronauts will add a camera 10 times more powerful than the already extraordinary cameras on board. They also will fit the Telescope with new, super-efficient solar array panels that will allow simultaneous operation of scientific instruments. These technologies were not available when Hubble was designed and launched.

The following sections identify some of the planned upgrades to HST and their anticipated benefits to performance. These improvements demonstrate that servicing HST results in significant new science data at greatly reduced cost.

7.1.1 Processor Improvements

During Servicing Mission 3A (SM3A), astronauts will replace Hubble's original main computer, a DF-224/coprocessor combination, with a completely new computer based on the Intel 80486 microchip. The new

computer will be 20 times faster and have six times as much memory as the one it replaces (see Fig. 7-3).

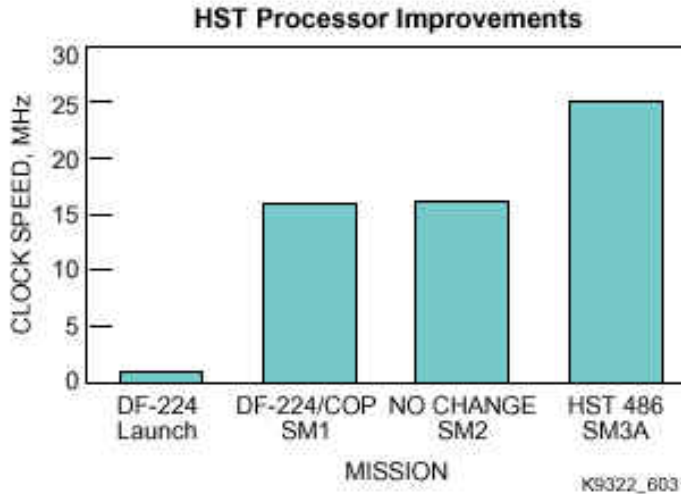

Fig. 7-3 Processor improvements on HST

In a good example of NASA's goal of "faster, cheaper, better," commercially developed, commonly available equipment was used to build the new computer at a fraction of the price it would have cost to build a computer designed specifically for the spaceflight environment.

The greater capabilities of the new computer will increase productivity for the Hubble observatory by performing more work in space and less work on the ground. The computer software uses a modern programming language, which decreases software maintenance cost.

7.1.2 Data Archiving Rate

With the addition of a second SSR on SM3A, Hubble's data storage capability will dramatically increase. The science data archiving rate will be more than 10 times greater than First Servicing Mission (1993) rates (see Fig. 7-4).

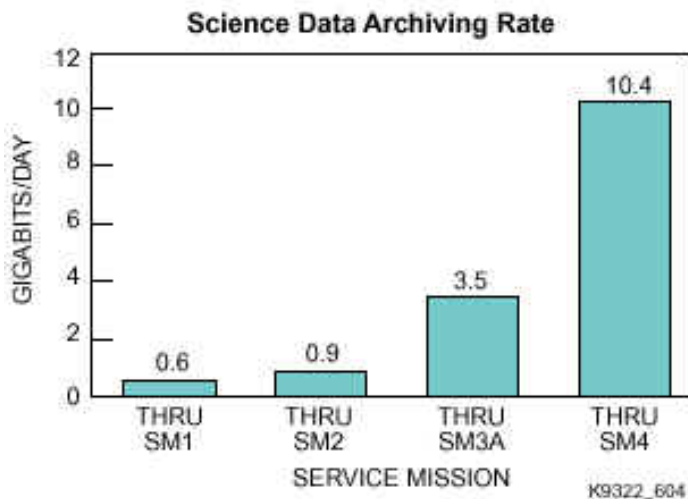

Fig. 7-4 Data archiving rate improvements

Prior to the Second Servicing Mission (SM2), Hubble used three reel-to-reel tape recorders designed in the 1970s. In February 1997 astronauts replaced one of the mechanical recorders with a digital SSR. During SM3A astronauts will remove a second mechanical recorder and install a second SSR.

Unlike the reel-to-reel recorders they replace, the SSRs have no reels, no tape, and no moving parts that can wear out and limit lifetime. Data is stored digitally in computer-like memory chips until Hubble's operators command its playback.

Although an SSR is about the same size and shape as the reel-to-reel recorder, it can store 10 times as much data: 12 gigabits of data instead of only 1.2 gigabits. This greater storage capacity allows Hubble's second-generation scientific instruments to be fully productive.

7.1.3 Detector Technology

Hubble's state-of-the-art detector technology allows the Telescope to capture and process faint amounts of light from the far reaches of space. Increased power and the resolution refinements achieved through advances in detector technology will greatly improve Hubble's performance and deliver even sharper, clearer, and more distinct images.

With the addition of the Advanced Camera for Surveys during SM3B, the total number of onboard pixels will have increased 4800 percent from SM2 in 1997 (see Fig. 7-5).

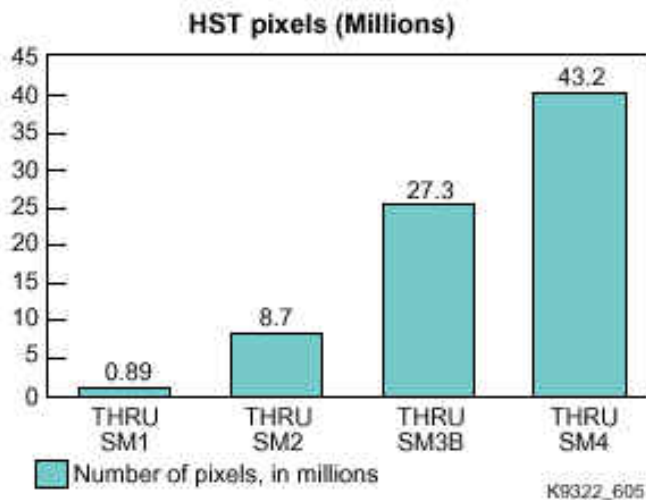

Fig. 7-5 Increase in onboard pixels

7.1.4 Cryogenic Cooler

Installation of the Near Infrared Camera and Multi Object Spectrograph (NICMOS) Cryogenic Cooler (NCC) during SM3B will greatly extend the life of Hubble's infrared cameras. The cryogenic cooler will increase NICMOS's life span from 1.8 years to 10 years (see Fig. 7-6).

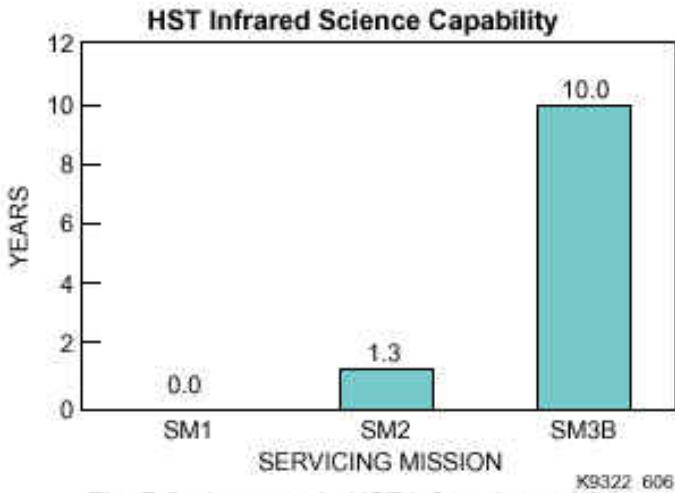

Fig. 7-6 Increase in HST infrared capability

NICMOS, which was installed on Hubble in 1997, has been a spectacular success. However, in January 1999 it ran out of the coolant necessary for conducting scientific operations. The NCC will preserve and extend the instrument's unique science contribution. The cost to develop and install the NCC is approximately \$16 million, while the cost of NICMOS was \$100 million. Installing a new cryocooler will increase by sevenfold the lifetime of the instrument and ensure a greater scientific return on the original investment.

7.1.5 Solar Arrays

The SM3B addition of new, rigid solar arrays will provide substantially more energy to Hubble. The increased power will enhance productivity by allowing simultaneous operation of up to four Hubble instruments (see Fig. 7-7).

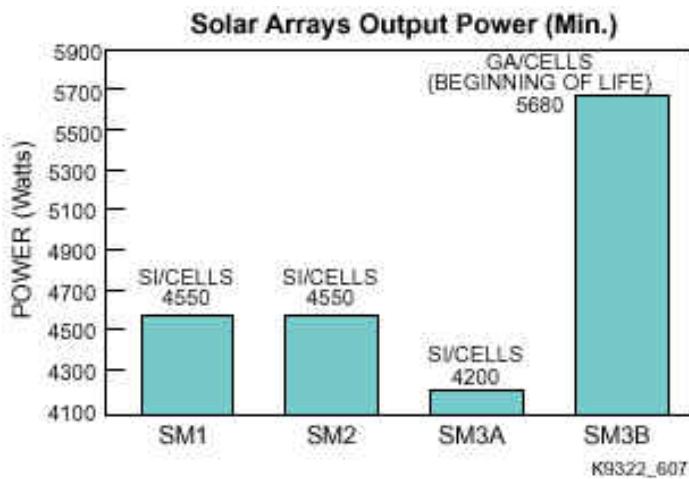

Fig. 7-7 Productivity gains on HST with new solar arrays

7.1.6 Simultaneous Science

One of the most exciting advances afforded by servicing has been the ability to increase simultaneous operations of scientific instruments from two to four. Originally, the instruments were designed to work in pairs. Following SM3B, advances in solar array technology and thermal transport systems will allow four science instruments to

operate at the same time, dramatically increasing Hubble's ability to study the universe (see Fig. 7-8).

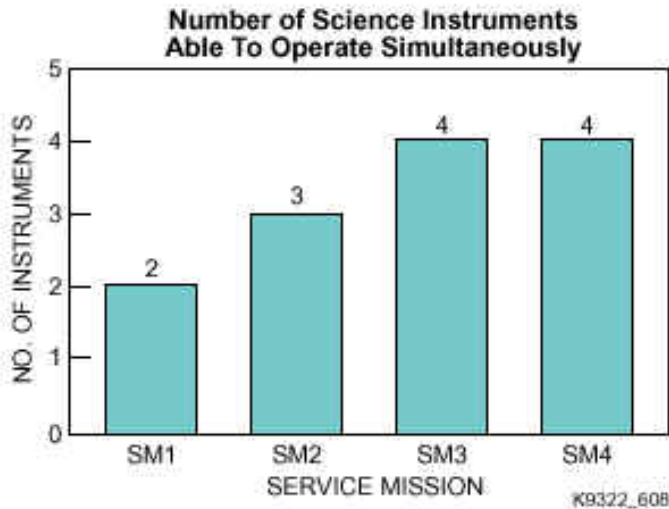

Fig. 7-8 Simultaneous use of HST science instruments

7.2 Accelerated Innovations The same cutting-edge technology that allows Hubble to peer deep into the universe also touches life closer to home. Hubble's innovative technology benefits mankind in numerous facets of everyday life, including medicine and manufacturing. Ultimately, these spin-off dividends enhance the U.S. economy and raise the American standard of living, making Hubble an even better value for the investment.

By teaming with companies and universities, Hubble's scientists and engineers push technology to new levels of sophistication. An example is the medical application of technology from the Space Telescope Imaging Spectrograph (STIS). A cancer detection application grew out of Hubble's need for highly sophisticated imaging capability, saving patients a significant amount of money and trauma.

Figure 7-9 shows the projected cost savings to patients as a result of the application of STIS technology.

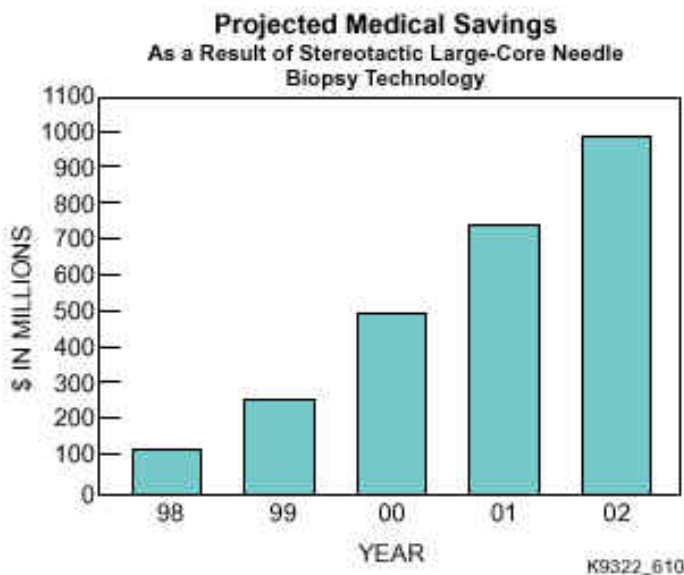

Fig. 7-9 Projected medical savings

7.2.1 Detecting Breast Cancer Before Black Holes

With STIS, one of two next-generation instruments installed on Hubble in February 1997, scientists can see deeper into space than ever before. NASA's fastest black hole hunter, STIS finds and studies black holes, teaches us more about how stars and planets form, and looks at very distant, early galaxies.

However, the charge-coupled device (CCD) developed for STIS to study outer space was used first to study "inner space," imaging breast tissue three years before STIS would ever see its first black hole.

To develop STIS, NASA needed a level of imaging technology not available commercially. NASA funded a company called SITE, Inc. to make a more sensitive CCD for Hubble. The new type of CCD found medical application as part of the Stereo Guide™ Breast Biopsy System manufactured by the LORAD division of ThermoTrex Corporation. The CCD enables the system to capture finely detailed digital x-ray images of breast tissue. The images help the doctor guide a needle into suspicious tissue and take a biopsy.

This procedure uses about half the x-ray dosage required for imaging for conventional surgical biopsies. It also saves patients time and pain and eliminates scarring and disfigurement. Patients can have the procedure under local rather than general anesthesia and can resume normal activities within minutes. Finally, because the new technique can be done in a doctor's office, it is less costly to perform. With more than 500,000 women undergoing breast biopsies each year in the U.S., radiologists predict the procedure will save over \$1 billion annually in national health care costs.

In 1997 this STIS detector technology was inducted into the United States Space Foundation's Space Technology Hall of Fame and was a finalist for the prestigious Discover Magazine Award for Technological Innovation. In 1998 it earned the Federal Laboratory Commission's Award for Technology Transfer.

7.2.2 Image Processing: Diagnosing Cancer Earlier

The CCDs used in digital mammography are not Hubble's only exciting news in the fight against breast cancer. Techniques developed for processing images from the Telescope may soon help detect breast cancer in its very early stages. The image processing techniques, used to correct the blurry images sent back to Earth from Hubble before the 1993 servicing mission, have proven effective in finding microcalcifications, whose presence in mammograms indicates breast cancer.

The Space Telescope Science Institute (STScI) developed a large repertoire of image processing software to compensate for the effects of the spherical aberration detected in Hubble's primary mirror soon after launch in April 1990. The software was designed to correct for the Telescope's loss of dynamic range and spatial resolution.

A group of medical and astronomical researchers from the STScI in Baltimore, Johns Hopkins University, and the Lombardi Cancer Research Center at the Georgetown University Medical Center in Washington, DC, is testing this image processing technique to detect signs of breast cancer in digitized mammograms. The collaborative effort has received funding from the National Science Foundation.

Although about one-third of breast cancer cases have microcalcifications smaller than 50 to 100 microns, current mammography can show only those 250 microns or larger. Image processing allows detection of smaller calcifications, therefore earlier cancer detection and treatment. The sooner a cancerous lesion is treated, the greater are the odds of full recovery. Applying image processing to medical treatment can save lives and preserve quality of life.